

SEARS
REPAIR
PARTS
MANUAL

**MODEL NO.
944.101081**

**IMPORTANT:
Read and follow
all Safety Rules
and Instructions
Before Operating
This Equipment**

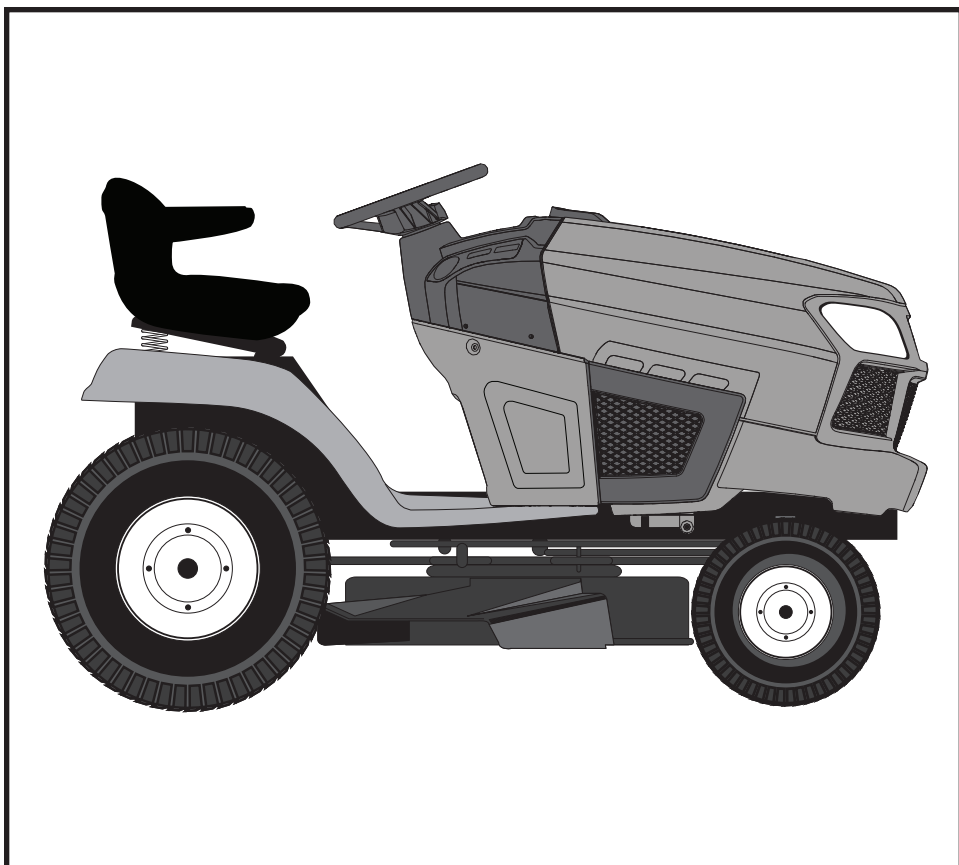

CRAFTSMAN®

**26.0 HP*
ELECTRIC START
54" MOWER
AUTOMATIC TRANSMISSION
GARDEN TRACTOR**

* The power rating as declared by the engine manufacturer is the average gross power output at the specified RPM of a typical production engine for the engine model measured using SAE Standards for engine gross power. Please refer to the engine manufacturer for details.

Sears Canada, Inc., Toronto, Ontario M5B 2B8

582245201 Rev. 5

04.11.17 BD
Printed in the U.S.A.

HOW TO USE THIS MANUAL

This manual is designed to provide the customer with a means to identify the parts on his/her tractor when ordering repair parts. The illustrations may or may not represent the actual assemblies; therefore, it is not recommended to use this manual as a guide to assemble or disassemble the tractor. Some hardware and parts are drawn larger in order to more readily identify them.

Each tractor has its own model number.

The model number for your tractor can be found on the fender under the seat.

When ordering parts, always give the following information:

- Product - "Tractor"
- MODEL NUMBER - "944.101081"
- Part Number
- Part Description

TABLE OF CONTENTS

SCHEMATIC	3
ELECTRICAL.....	4-5
CHASSIS	6-7
DRIVE.....	8-9
ENGINE.....	10-11
STEERING	12-13
MOWER DECK	14-15
MOWER LIFT.....	16-17
SEAT	18
DECALS.....	19
TRANSAXLE BREAKDOWN	20-21
ENGINE BREAKDOWN.....	22-33
WARRANTY.....	35
SEARS SERVICE	36

TRACTOR - - MODEL NUMBER 944.101081

SCHEMATIC

SCH12

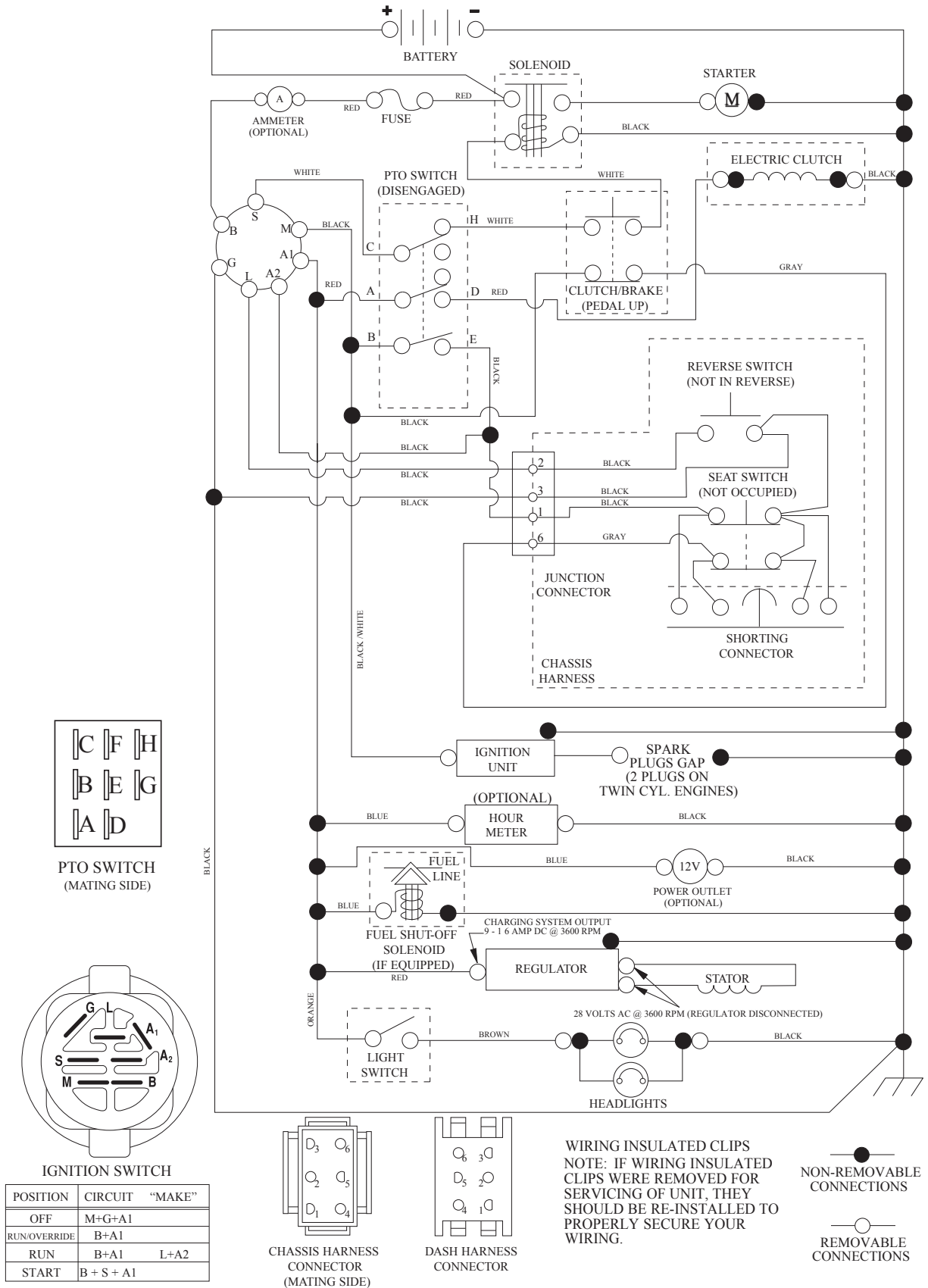

TRACTOR - - MODEL NUMBER 944.101081

ELECTRICAL

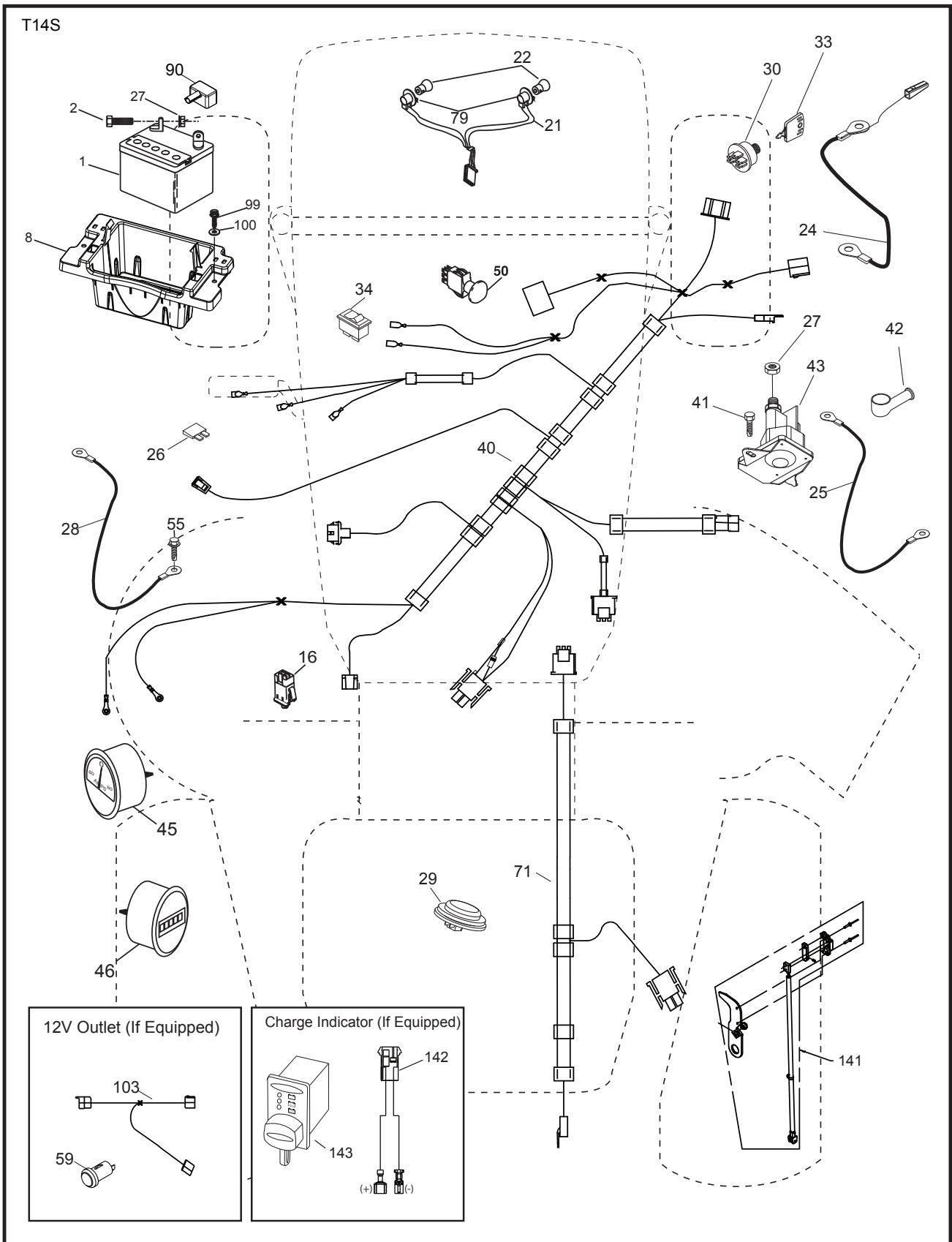

TRACTOR - - MODEL NUMBER 944.101081

ELECTRICAL

KEY NO.	PART NO.	DESCRIPTION
1	163465	Battery
2	74760412	Bolt Hex Head 1/4-20 x 3/4
8	587205101	Box Battery
16	176138	Switch Interlock Push-In
21	400252	Harness Socket Light w/4152J
22	4152J	Bulb Light
24	585555601	Cable Battery
25	585555501	Cable Starter
26	175158	Fuse
27	73510400	Nut Keps Hex 1/4-20 unc
28	416588	Cable, Ground
29	401545	Switch, Seat
30	193350	Switch, Ign
33	411934	Key/Chain
34	110712X	Switch Light/Reset
40	501133101	Harness Ign. Dash
41	17720408	Screw 1/4-20 x 1/2
42	131563	Cover, Terminal
43	192507	Solenoid
45	587553902	Ammeter Round
46	587554002	Hourmeter Round
50	174653	Switch, PTO
55	17060512	Screw 5/16-18 x 3/4
71	194276	Harness Ignition
79	175242	Socket Asm. Bulb
90	435395	Cover Terminal Battery
99	17670412	Screw Hexwsh Thdrol 1/4-20 x 3/4
100	19091416	Washer 9/32 x 7/8 x 16 Ga.
141	421225	Kit G700/G730 ROS Service

NOTE: All component dimensions given in U.S. inches
1 inch = 25.4 mm

TRACTOR - - MODEL NUMBER 944.101081

CHASSIS

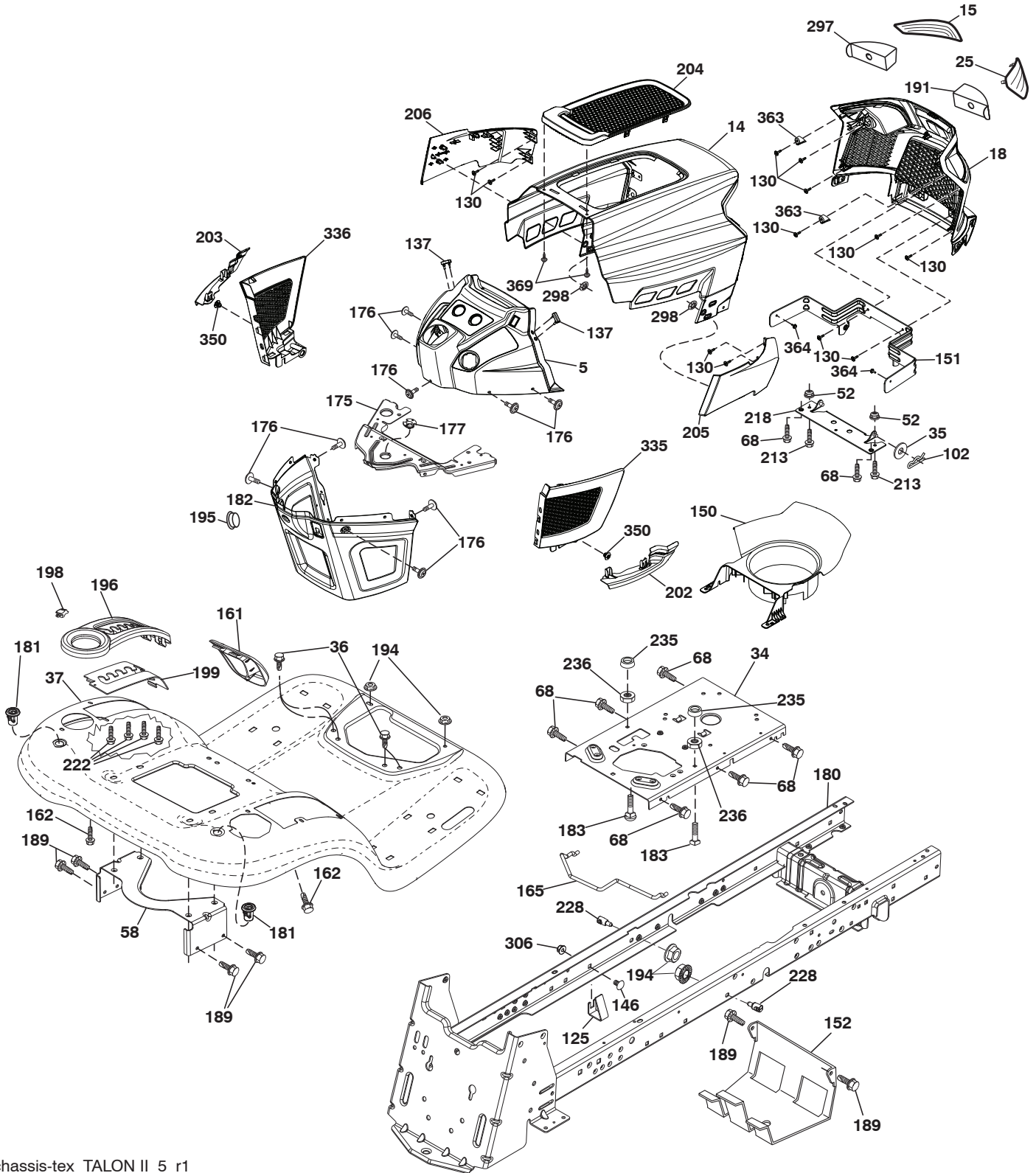

chassis-tex_TALON II_5_r1

TRACTOR - - MODEL NUMBER 944.101081

CHASSIS

KEY NO.	PART NO.	DESCRIPTION
5	580485904	Dash
14	580354407	Hood
15	580485601	Lens LH
18	580485303	Grille
25	580484501	Lens RH
34	580910801	Plate engine
35	191111116	Washer 11/32 x 11/16 x 16 Ga.
36	17060512	Screw 5/16-18 x 3/4
37	400009X428	Fender
52	73680500	Nut Crown lock 5/16-18
58	194314	Bracket
68	17490508	Screw Thdrol 5/16-18 x 1/2
102	4497H	Retainer Spring 1"
125	581684801	Clip Fuel Line
130	416358	Screw # 10 x .750 BOS Thread
137	407590	Bumper Dash
146	581857901	Bolt
150	580485501	Duct Heat Hood
151	580663302	Bracket Pivot
152	199535	Shield Browning/Debris
161	193097X428	Console Fuel Window
162	142432	Screw Hex Wsh Hi-Lo 1/4 x 1/2
165	196826	Support Tank Rear
175	196304	Crossmember
176	400776	Screw 10-24 x 5/8 Wshd Qdrx
177	195228	Bushing Steering
180	195477	Chassis
181	193102X428	Bushing Mtg. Fender Crgo.
182	406859	Dash Lower
183	74520520	Bolt 5/16-18 x 1-1/4
189	17000512	Screw 5/16-18 x 3/4
191	580485101	Mylar Headlight/Reflective Lens RH
194	73900500	Nut Lock Hex Flange 5/16-18
195	401556X428	Plug Hole Dash 12V Adapter
196	420545	Console Asm. Deck Lift
198	197300X421	Indicator Deck Lift
199	419350	Plate Deck Lift
202	580485002	C-Closeout Lwr Trm RH
203	580484802	C-Closeout Lwr Trm LH
204	580484701	Hood Top Vent
205	580843707	Assembly Corner RH
206	580843807	Assembly Corner LH
213	74760512	Bolt hex HD 5/16-18 unc x 3/4
218	580897301	Pivot Hood Assy
222	137729	Screw 1/4-20 x 5/8
228	195161	Stud Fastener
235	406129	Spacer Fender
236	73930500	Nut Center Lock 5/16-18
297	580484901	Mylar Headlight/Reflective Lens LH
298	580851001	Nut Push
306	73900600	Nut Lock
335	580484602	C-Side Closeout RH
336	580484402	C-Side Closeout LH
350	445143	Clip X-Mass Tree
363	580724501	Cap Talon Grille
364	17060408	Screw
369	421756	Screw #10 x 0.500 BOS Thread
- -	421264	Brush Guard

NOTE: All component dimensions given in U.S. inches
1 inch = 25.4 mm

TRACTOR - - MODEL NUMBER 944.101081

DRIVE

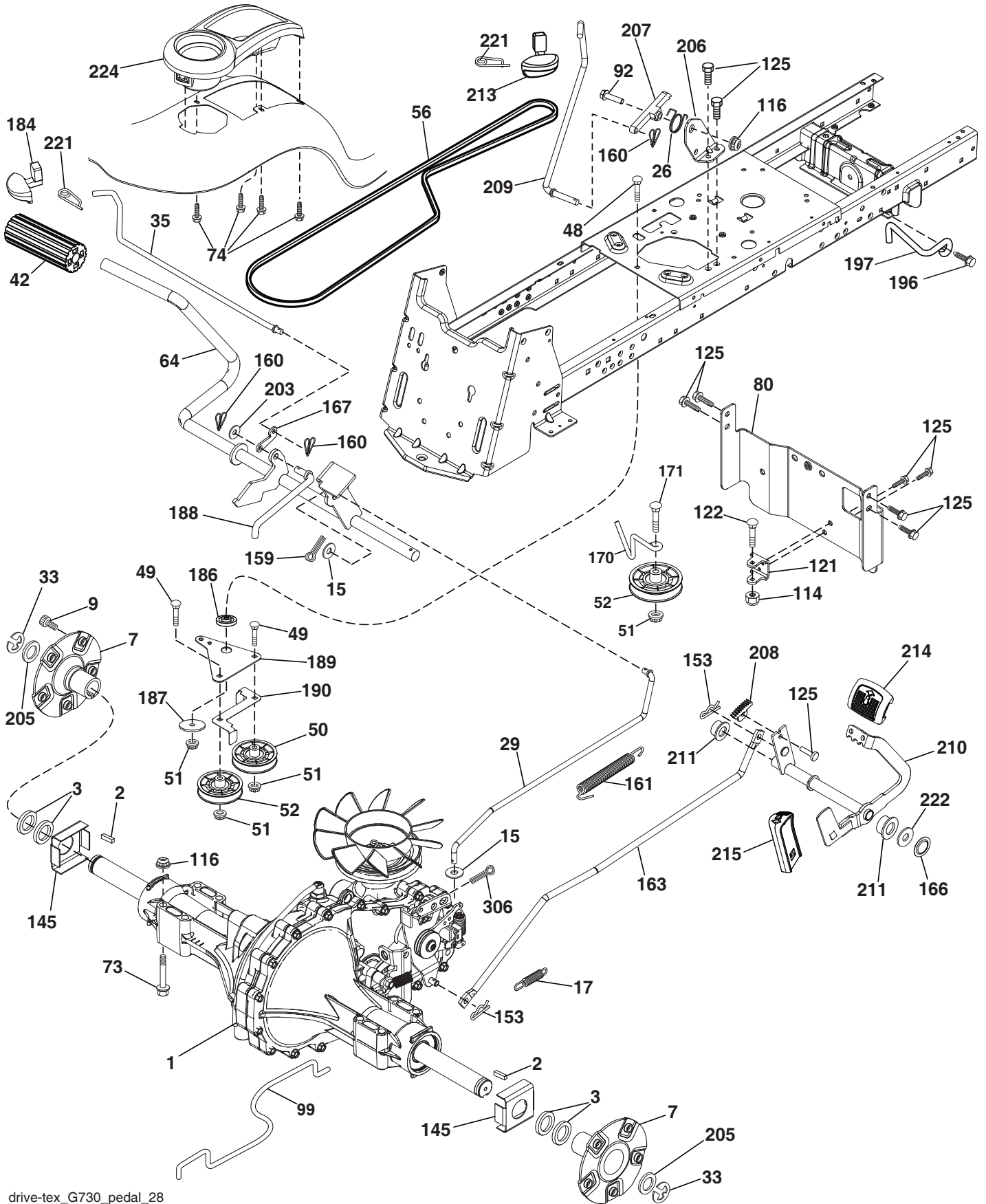

TRACTOR - - MODEL NUMBER 944.101081

DRIVE

KEY NO.	PART NO.	DESCRIPTION	KEY NO.	PART NO.	DESCRIPTION
1	---	Transaxle, Hydro G7-BCBB-1XDC-1FCA (420331)	161	105709X	Spring, Return, Clutch
2	7070E	Key 1/4 x 2.5	163	418185	Rod Pedal Control
3	7563R	Washer Thrust Axle Hardened	166	429164	Nut Push .625
7	199837	Hub Asm. Wheel	167	405257	Latch Brake Parking
9	140080	Bolt Hub Wheel	184	196439X428	Handle Parking Brake
15	19131316	Washer 13/32 x 13/16 x 16 Ga.	186	194321	Spacer Retainer
17	197296	Spring, Brake	187	19133210	Washer
26	199679	Spring Return Cruise	188	582217001	Link Clutch Ground Drive, Long
29	418186	Rod, Brake	189	407504	Bellcrank Ground Drive
33	12000053	Ring E	190	407505	Keeper Bellcrank Ground Drive
35	583864501	Rod, Brake, Park	196	17000616	Screw 3/8-16 x 1
42	8883R	Cover, Foot Pedal	197	585658601	Bracket Clutch Anti-Rotation
48	72110612	Bolt Carr Sh 3/8-16 x 1-1/2 Gr. 5	203	19111116	Washer 11/32 x 11/16 x 16 Ga.
49	72110614	Bolt	205	123800X	Washer 1-1/32 x 1-5/8 x 16 Ga.
50	194327	Pulley Idler Flat	206	448596	Bracket Mount Latch Cruise
51	73900600	Lock Nut 3/8-16	207	587031401	Latch Control Cruise
52	194326	Idler V-Groove 910" Offset	208	197869	Gear Sector Control Cruise
56	140294	V-Belt, Drive	209	199592	Rod Control Cruise
64	197865	Shaft Asm. Pedal Brake Control	210	197860	Rocker Asm. Pedal Control
73	74490548	Bolt Hex 5/16-18 x 3 Gr. 5	211	120183X	Bearing Nylon
74	142432	Screw 1/4 x 1/2	213	196441X428	Knob Control Cruise
80	418184	Strap Torque	214	421263	Pedal Forward
92	74760520	Bolt 5/16-18 x 1/2	215	197301X428	Pedal Reverse
99	418188	Spring Bypass	221	403187	Retainer Spring Clip Handle
114	73800500	Nut Lock Hex W/Ins. 5/16-18 unc	222	79212010	Washer 21/32 x 1-1/4 x 10 Ga.
116	73900500	Nut Lock Hex Flange 5/16-18	224	193099X428	Console Toolbox
121	175611	Bracket Strap Torque	306	76020416	Pin Cotter
122	72010520	Bolt 5/16-18 x 2.50			
125	17000512	Screw 5/16-18 x 3/4			
145	163168	Washer Axle Flange			
153	4497H	Retainer Spring			
159	76020412	Pin Cotter 1/8 x 3/4			
160	169484	Retainer Clip			

NOTE: All component dimensions given in U.S. inches
1 inch = 25.4 mm

TRACTOR - - MODEL NUMBER 944.101081

ENGINE

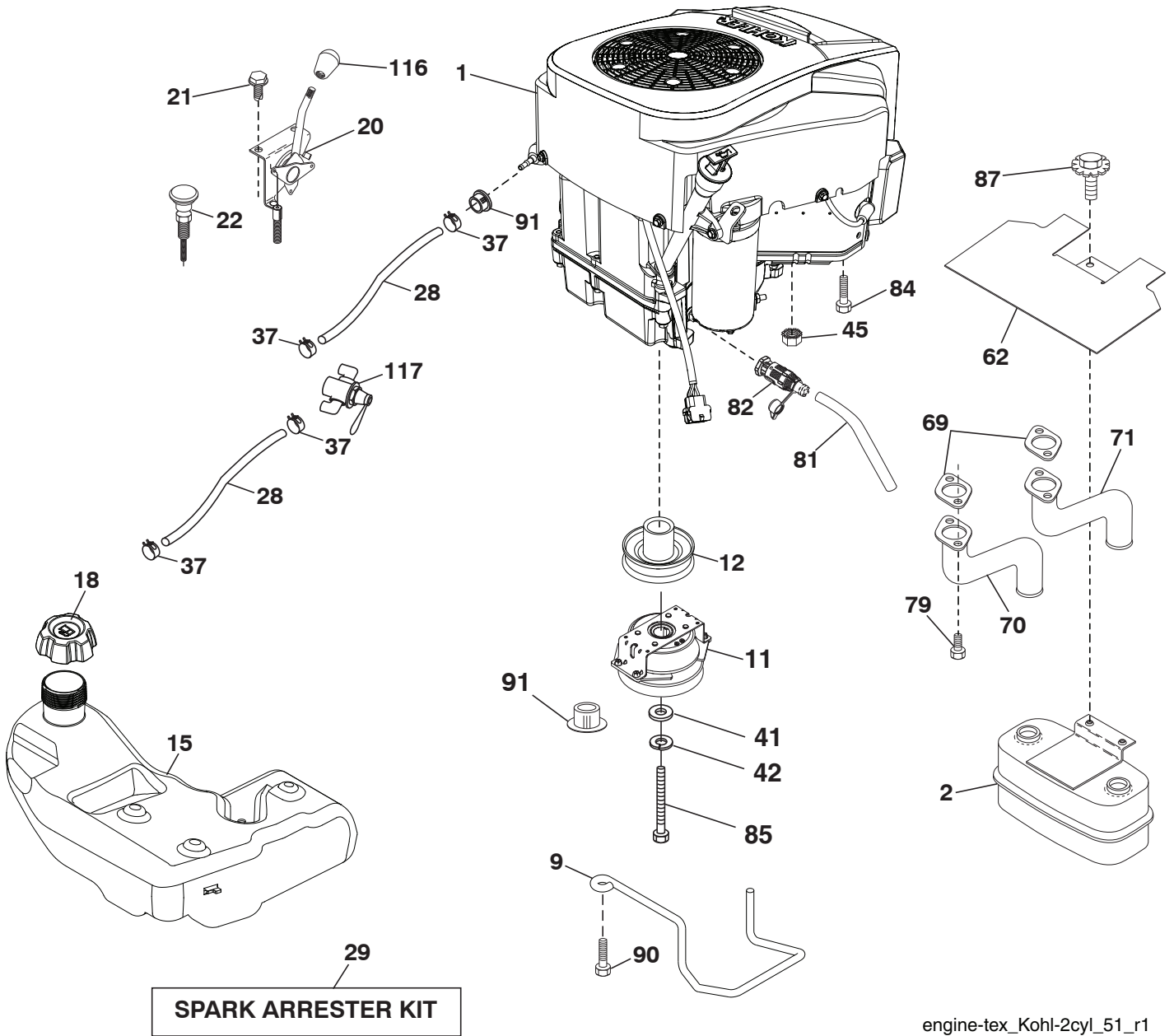

engine-tex_Kohl-2cyl_51_r1

TRACTOR - - MODEL NUMBER 944.101081

ENGINE

KEY NO.	PART NO.	DESCRIPTION
1	- - - -	Engine Kohler Model No. KT745-3016 (585446401) (See Engine Breakdown)
2	445962	Muffler
9	408667	Keeper Belt Engine
11	587241401	Clutch Electric
12	194343	Pulley Engine
15	422804	Tank Fuel 4.0
18	584248701	Cap Asm Fuel
20	587631703	Control Throttle
21	438562	Screw 10 x .750 BOS Thread
22	187767X421	Control Choke
28	401135	Fuel Line
29	137180	Spark Arrester Kit
37	123487X	Clamp Hose
41	126197X	Washer 1-1/2 OD x 15/32 ID x .250
42	10040700	Washer Lock 7/16
45	73510400	Nut Keps Hex 1/4-20 unc
62	434017	Shield Heat Muffler
69	186054	Gasket
70	583954501	Tube Exhaust LH
71	583954801	Tube Exhaust RH
79	192334	Screw 5/16-18 x 3/4
81	148456	Tube Drain Oil Easy
82	428287	Valve Drain Oil
84	17120616	Screw 3/8-16 x 1
85	581636201	Bolt Hex 7/16-20 x 3.0 x Gr. 5
87	198239	Bolt 5/16-18 unc x 1 w/Sems
90	17000616	Screw 3/8-16 x 1
91	187495	Bushing
116	423109X421	Knob Oval Tapered 3/8-16
117	420828	Valve Fuel Reserve

NOTE: All component dimensions given in U.S. inches
1 inch = 25.4 mm

TRACTOR - - MODEL NUMBER 944.101081

STEERING ASSEMBLY

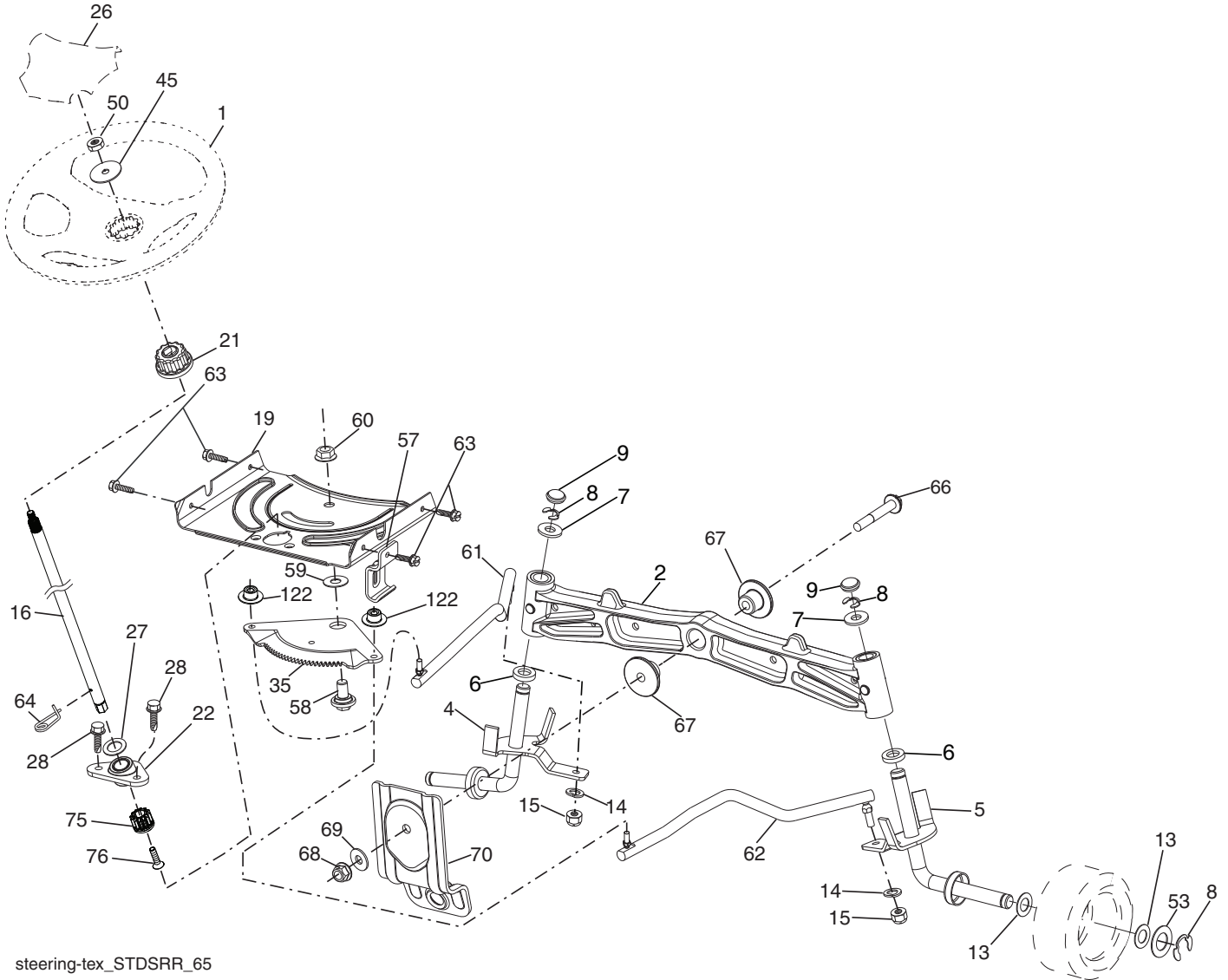

steering-tex_STDSRR_65

TRACTOR - - MODEL NUMBER 944.101081

STEERING ASSEMBLY

KEY NO.	PART NO.	DESCRIPTION
1	414851X421	Wheel, Steering
2	195968	Axle Asm., Front
4	403089	Spindle Asm., LH
5	403090	Spindle Asm., RH
6	6266H	Bearing, Race Thrust Harden
7	121748X	Washer 25/32 x 1-5/8 x 16 Ga.
8	1200029	Ring, Clip #T5304-75
9	184946X667	Cap, Spindle
13	121749X	Washer 25/32 x 1-1/4 x 16 Ga.
14	10040600	Washer Lock Hvy Hlcl Spr 3/8
15	73540600	Nut, Crown Lock 3/8-24 unf
16	587016002	Steering Shaft
19	194729	Plate Steering
20	199676X428	Boot, Steering
21	586840201	Adapter Wheel Steering
22	585029802	Bearing
26	414852X421	Insert, Wheel Steering
27	19211616	Washer
28	17000612	Screw 3/8-16 x 3/4
35	194732	Gear, Sector Plate
45	587016401	Washer 3/8 ID 2-3/8 OD 12 Ga. PLTD
50	73900600	Nut Lock Flg 3/8-16 unc
53	188967	Washer Hardened .793 x 1.637 x .060
57	197246	Bracket Upstop
58	194747	Bolt Shoulder Sector Pivot CFM
59	194748	Washer Thrust Sector Steering
60	73971000	Nut Flange Lock 5/8-11
61	194740	Draglink, LH
62	194741	Draglink, RH
63	17000512	Screw 5/16-18 x 3/4
64	199849	Retainer Clip Spring Steering
66	71020748	Bolt Hex Fghd 7/16-14 x 3 Serr
67	194737	Bushing PM Front Axle
68	73900700	Nut Lock Flange 7/16-14 Gr. 5
69	199162	Washer 1.5 x .505 x .118
70	585338801	Bracket Deck Susp. Front
75	580683701	Pinion
76	580683601	Screw Head Sock
122	444962	Cap Gear Sector

NOTE: All component dimensions give in U.S. inches
1 inch = 25.4 mm

TRACTOR - - MODEL NUMBER 944.101081

MOWER DECK

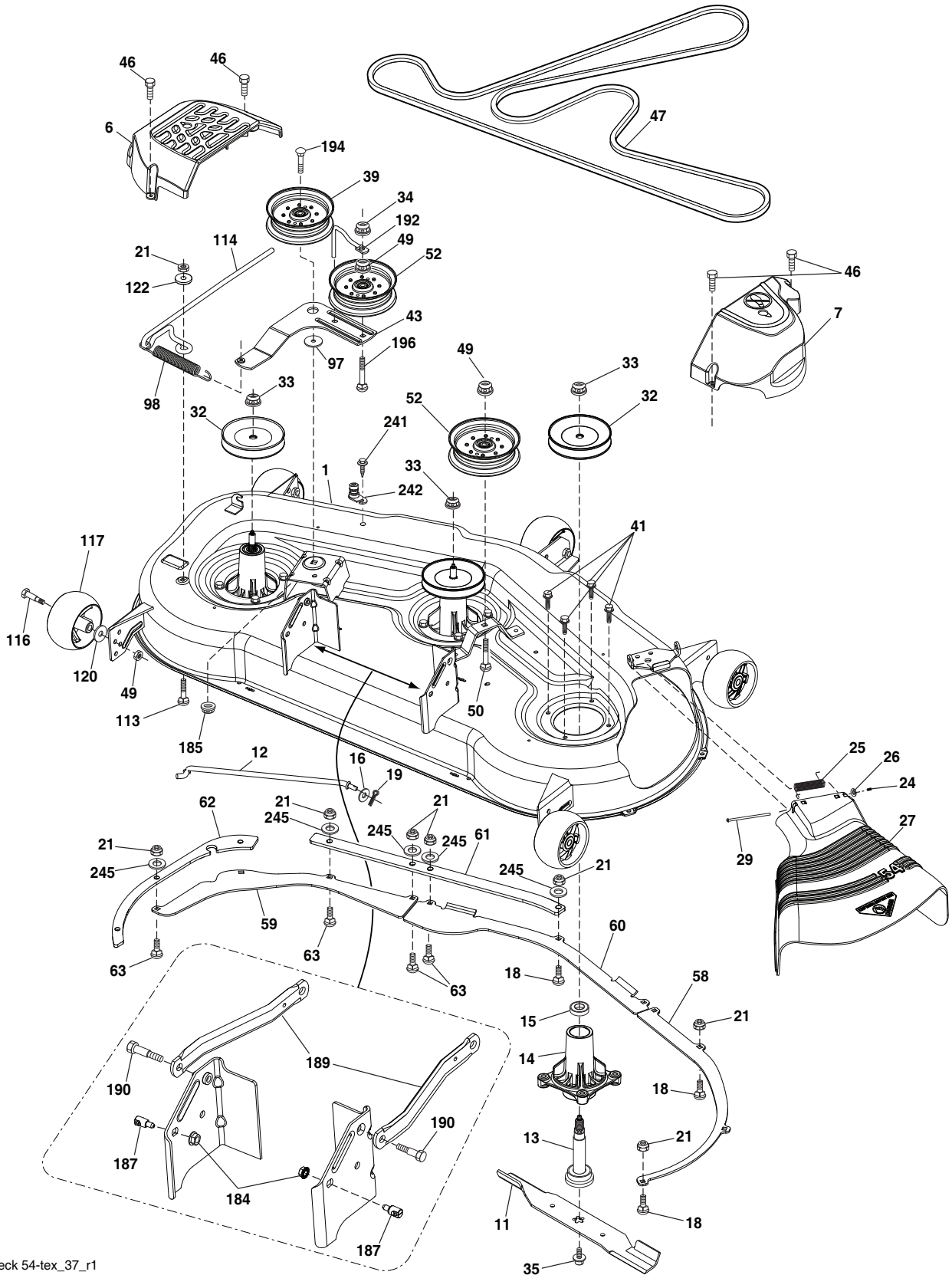

mower_deck 54-tex_37_r1

TRACTOR - - MODEL NUMBER 944.101081

MOWER DECK

KEY NO.	PART NO.	DESCRIPTION	KEY NO.	PART NO.	DESCRIPTION
1	195632X421	Deck Weldment Mower	62	585322805	Plate Reinforcement Side
6	196066	Cover Mandrel LH	63	72110510	Bolt Carr. 5/16-18 x 1-1/4 Gr. 5
7	197181	Cover Mandrel RH	97	178515	Washer Hardened
11	187256	Blade Bagging	98	196105	Spring Drive
12	400337	Rod Anti Sway	113	72110508	Bolt Rdhd Sqnk 5/16-18 x 3/4
13	587256401	Shaft Asm.	114	187556	Rod Tension Relief
14	187281	Housing, Mandrel	116	193406	Bolt, Shoulder
15	585323901	Bearing, Mandrel	117	174873	Gauge Wheel
16	19131312	Washer 13/32 x 13/16 x 12 Ga.	120	19132012	Washer 13/32 x 1-1/4 x 12 Ga.
18	72140505	Bolt RdHd 5/16-18 unc x 5/8	122	187557	Bushing Tension Relief
19	194208	Pin Cotter 5/16 Bow Tie Lock	184	73900500	Nut Lock Flange 5/16-18
21	73680500	Nut, Crownlock 5/16-18 unc	185	73900700	Nut Lock Flange 7/16-14 Gr. 5
24	105304X	Cap Sleeve	187	195161	Stud Fastener w/"D" Anti-Rotation
25	178102	Spring, Torsion	189	195185	Arm Susp. Mower Rear
26	110452X	Nut, Push	190	196539	Bolt Shoulder
27	187257X428	Deflector Shield	192	198468	Keeper Belt Idler
29	131491	Rod, Hinge	194	74490736	Bolt Carr Sqnk 3/8-16 x 2-1/4
32	153535	Pulley, Mandrel	196	72140620	Bolt RdHd 3/8-16 unc x 2-1/2 Gr. 5
33	400234	Nut, Flg. Top Lock	241	152927	Screw
34	73680600	Nut	242	415598	Washout Port
35	584309301	Screw	245	19111116	Washer 11/32 x 11/16 x 16 Ga.
39	197380	Pulley, Idler	--	587125401	Mandrel Asm. Service (Includes Key Nos. 13-15 and 33)
41	584953901	Bolt Hex Wshr	--	416405	Coupling Quick Connect
43	196065	Arm, Idler	--	587739001	Replacement Mower, Complete
46	137729	Screw, Thdroll. 1/4-20 x 5/8			
47	587686701	V-Belt, Mower			
49	73900600	Nut, Lock Flg. 3/8-16 unc			
50	72110616	Bolt, Carr. 3/8-16 x 2			
52	197379	Pulley Idler			
58	187342	Baffle Right			
59	187344	Baffle Left			
60	187607	Baffle Center			
61	585322605	Plate Reinforcement Front			

NOTE: All component dimensions given in U.S. inches
1 inch = 25.4 mm

TRACTOR - - MODEL NUMBER 944.101081

MOWER LIFT

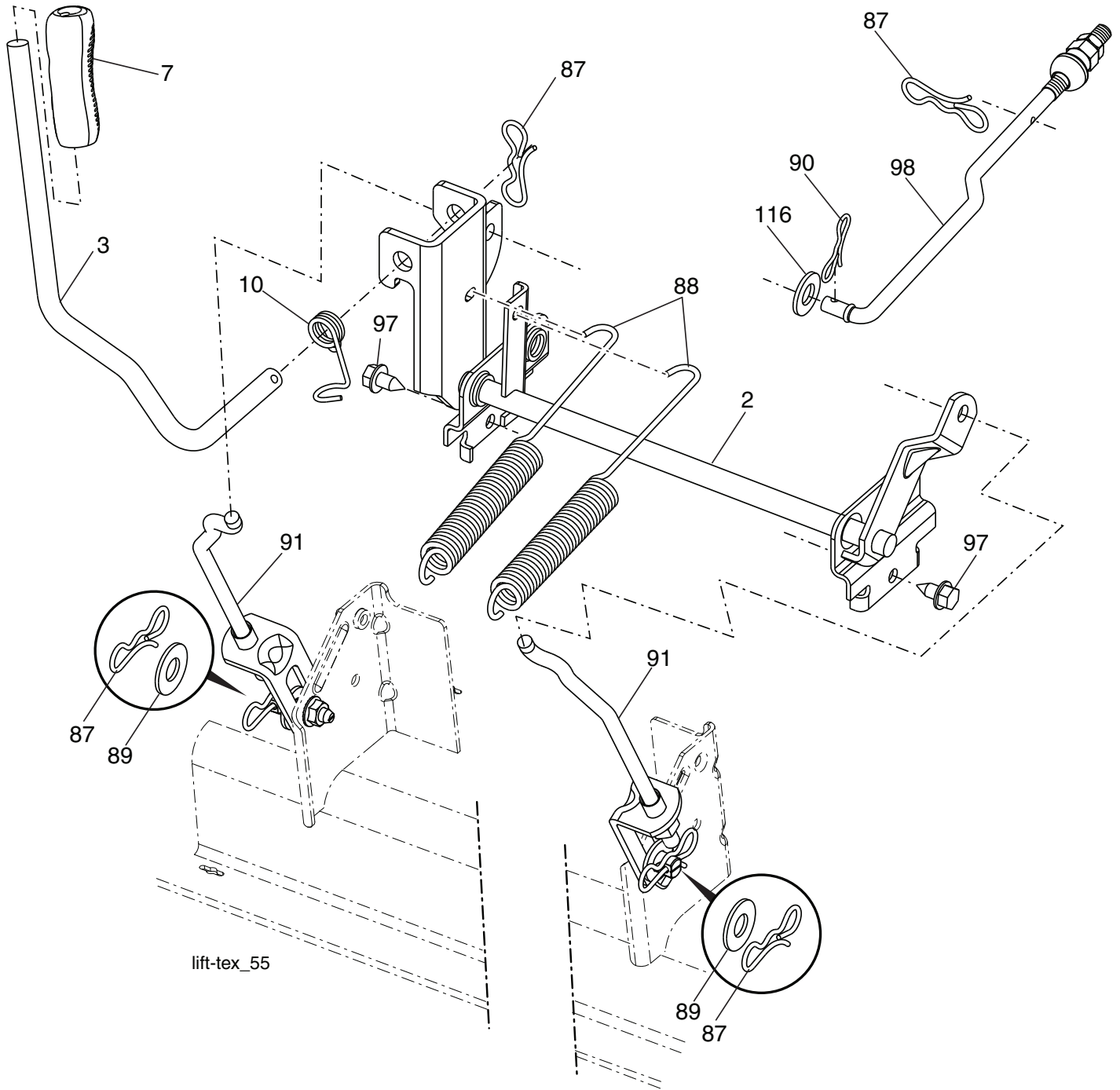

TRACTOR - - MODEL NUMBER 944.101081

MOWER LIFT

KEY NO.	PART NO.	DESCRIPTION
2	422027	Shaft Asm., Lift
3	419497	Lever Asm., Lift RH
7	445060X421	Grip, Lever
10	196314	Spring Torsion
87	194209	Pin Cotter 7/16 Bow Tie Lock
88	195304	Spring Lift Assist
89	19191912	Washer Clear Zinc
90	194208	Pin Cotter 5/16 Bow Tie Lock
91	403407	Link Lift Asm. Rear
97	17000612	Screw 3/8-16 x .75 R.Z
98	195264	Link Asm. Susp. Front Mower
116	19151516	Washer 15/32 x 15/16 x16 Ga.

NOTE: All component dimensions given in U.S. inches
1 inch = 25.4 mm

TRACTOR - - MODEL NUMBER 944.101081

SEAT ASSEMBLY

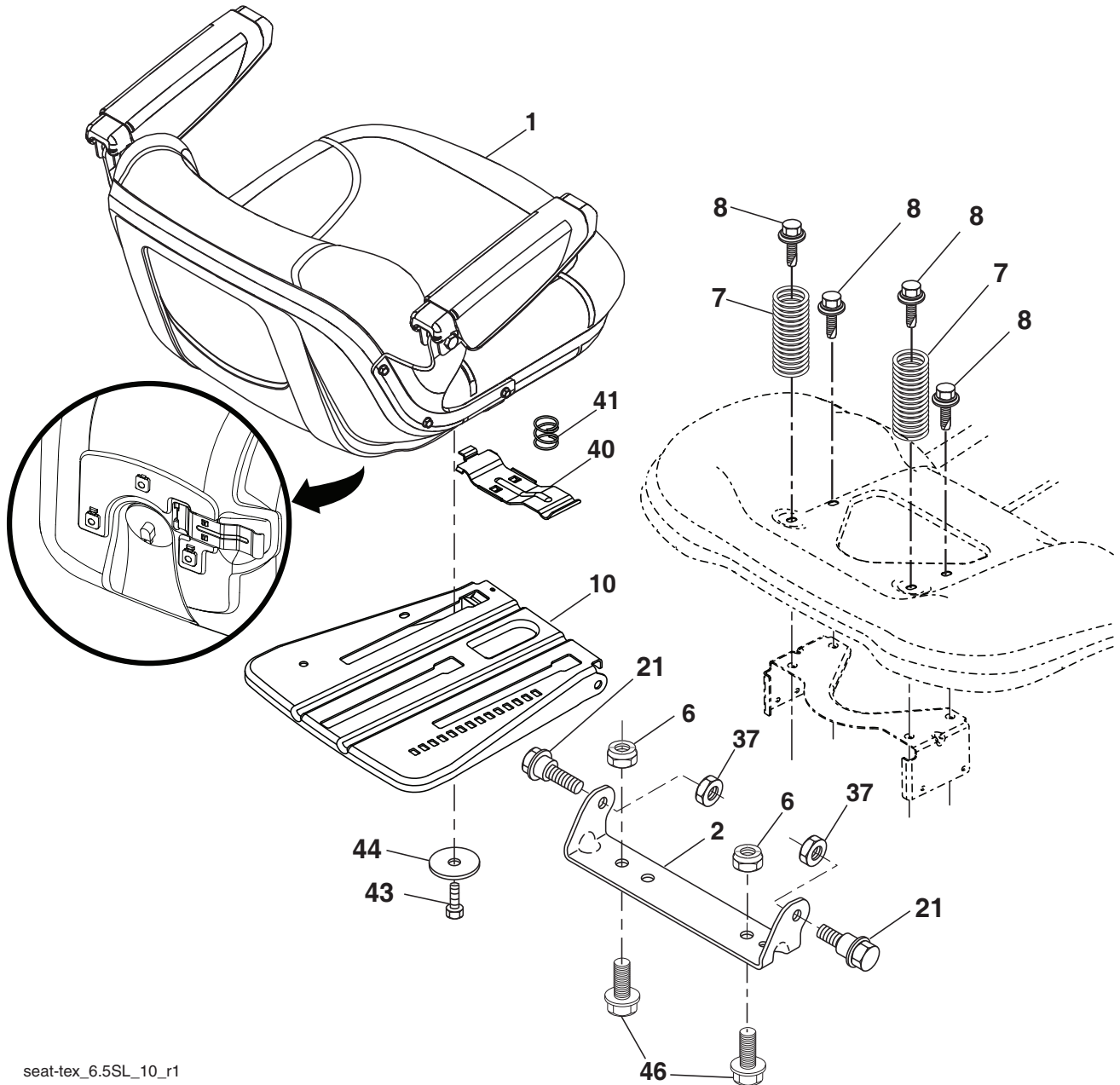

seat-tex_6.5SL_10_r1

KEY NO.	PART NO.	DESCRIPTION
1	586507702	Seat
2	180166	Bracket Pivot Fender
6	73800600	Nut, Lock w/Ins. 3/8-16 unc
7	587613301	Spring, Seat Cprsn
8	171877	Bolt 5/16-18 unc x 3/4 w/Sems
10	196977	Pan, Seat
21	587907801	Bolt, Shoulder 5/16-18 x 5/8
37	73800500	Nut, Lock 5/16-18 unc

KEY NO.	PART NO.	DESCRIPTION
40	197661	Handle Slide Seat
41	198200	Spring Latch Seat
43	74760612	Bolt 3/8-16 unc x 3/4
44	19133812	Washer 13/32 x 2-3/8 x 12 Ga.
46	588090401	Bolt 3/8-16 x 1, 1.25 OD

NOTE: All component dimensions given in U.S. inches
1 inch = 25.4 mm

TRACTOR -- MODEL NUMBER 944.101081

DECALS

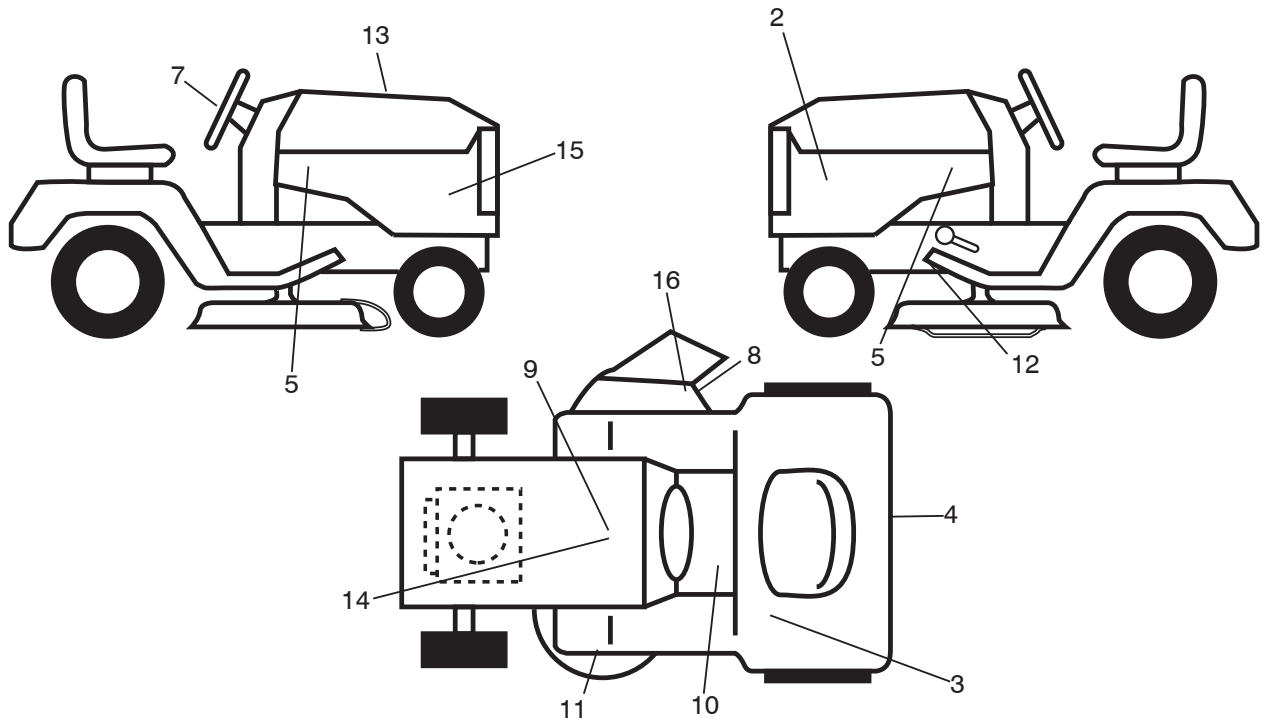

KEY NO.	PART NO.	DESCRIPTION
2	586208402	Decal, Sideskirt LH
3	586724301	Decal, Warn. Reserve Fuel
4	587390301	Decal, Fender
5	586456301	Decal, Hood
7	587389701	Decal, Steering
8	581580002	Decal, Mower Schematic
9	149517	Decal, Battery Warning
10	581579001	Decal, Fender
11	581724501	Decal, Mower Caution
12	421534	Decal, Mower V-Belt Schematic
13	582458201	Decal Replacement

KEY NO.	PART NO.	DESCRIPTION
14	448709	Decal, Battery Diehard
15	586208401	Decal, Sideskirt RH
16	584904601	Decal, Deck/Deflect Warning
--	581724801	Decal, Bypass
--	193279X428	Pad Footrest RH
--	193101X428	Pad Footrest LH
--	115817824	Manual, Operator's (English/French)
--	582245201	Manual, Parts (English/French)

WHEELS AND TIRES

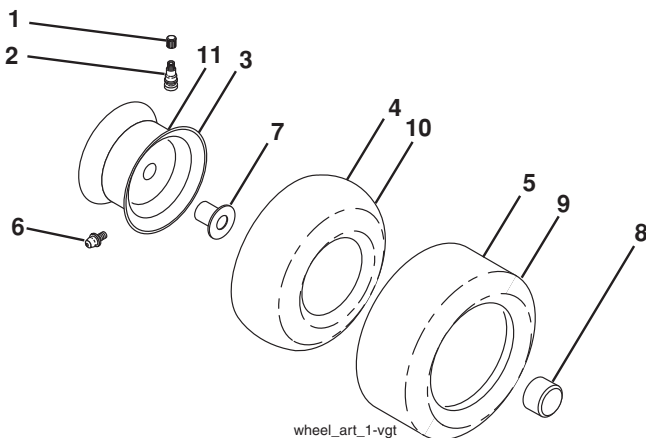

KEY NO.	PART NO.	DESCRIPTION
1	59192	Cap, Valve, Tire
2	65139	Stem, Valve
3	106228X421	Rim Assembly, Front
4	8134H	Tube, Front (Service Item Only)
5	106230X	Tire, Front 16 x 6.5-8
6	278H	Fitting, Grease (Front Wheel Only)
7	9040H	Bearing, Flange (Front Wheel Only)
8	104757X428	Cap, Axle (Front Wheel Only)
9	105588X	Tire, Rear 23 x 10.5-12
10	7154J	Tube, Rear (Service Item Only)
11	106277X421	Rim Assembly, Rear
--	144334	Sealant, Tire (10 oz. Tube)

NOTE: All component dimensions given in U.S. inches
1 inch = 25.4 mm

TRACTOR - - MODEL NUMBER 944.101081

HYDRO GEAR TRANSAXLE - - MODEL NUMBER G7-BCBB-1XDC-1FCA

G7-BCBB-1XDC-1FCA

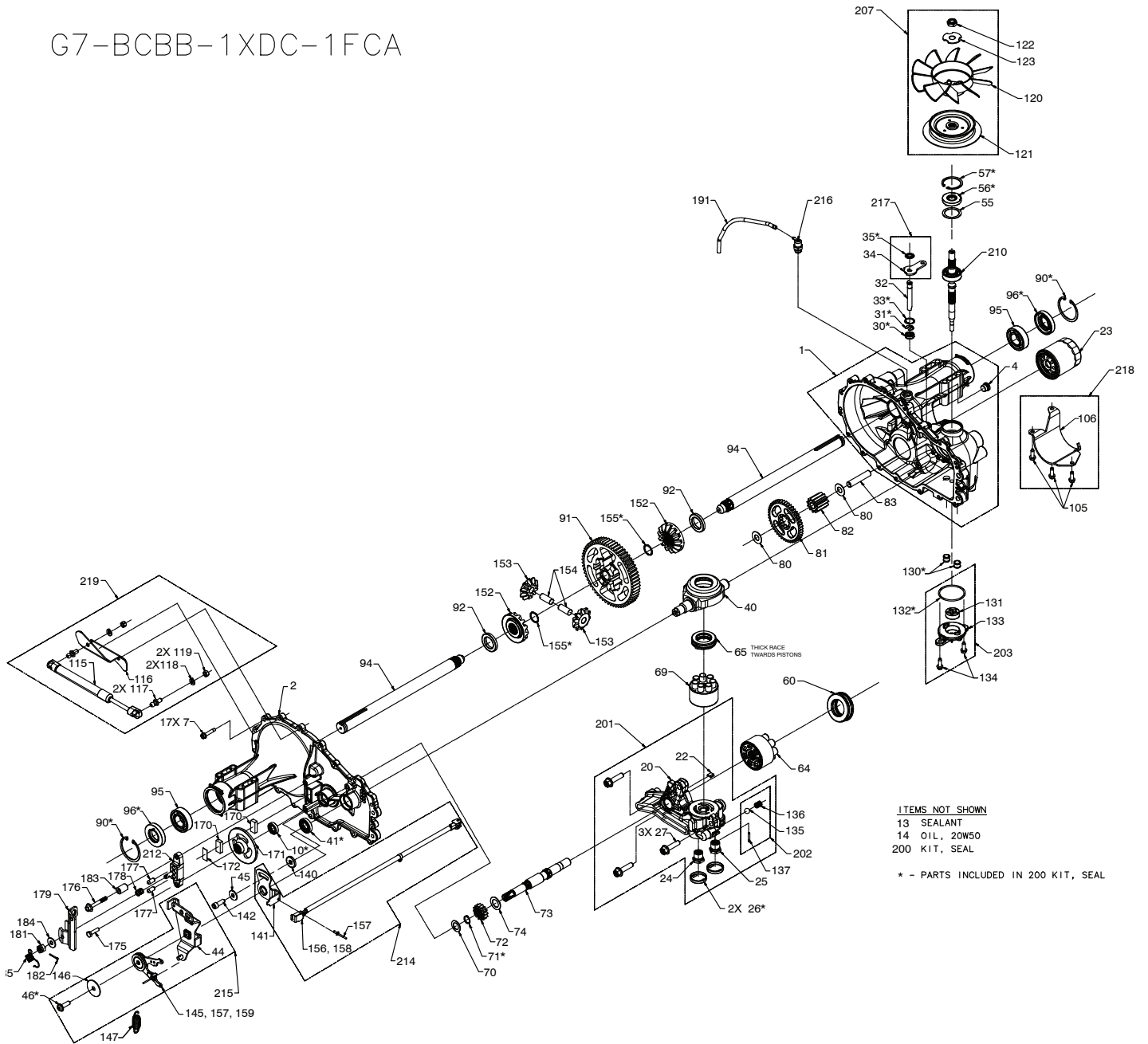

KEY PART NO. NO.

1	421183	Kit, Housing Main
(4)		Plug 9/16-18 (Metal)
		Housing, Main
		Pin, .25 X .375
		Bushing, .624 X .719 X .562
		Bushing, .865 X .985 X .790
		Bearing, Flange 1.0 X 1.376 X .99
2	421184	Kit, Housing, Side
		Housing, Side
		Bushing, .624 X .729 X .562
		Bushing, .865 X .985 .790
		Bearing, Flange 1.0 X 1.376 X .99
4	170434	Plug 9/16-18 (Metal)
7	170356	Hfhcs 1/4-20 X 1.25"
10	417764	Seal, Lip .625 X 1.0
13	178322	Tube, Sealant

KEY PART NO. NO.

14		Oil, 20w50
22	421185	Plate, Bypass
23	421186	Filter, Oil
26	421187	Seal, Plug 1.250 X .250
27	421188	Hfhcs 3/8-16 X 1.5 (Patch)
30	421189	Seal, Lip .375 X .75 X .25
31	421190	Ring, Retaining .375 External
32	421191	Rod, Bypass
33	421192	Ring, Retaining .750 Internal
35	421193	Retaining Ring
40	170354	Trunnion, Swashplate
41	170363	Seal, Lip 18 X 32 X 7
45	142884	Washer, .24 X .88 X .06
46	421194	Twhcs 5/16-24 X 1.00 (Patch)
55	170360	Washer, 1.23 X 1.56 X .04
56	170361	Seal, Lip 17 X 40 X 7

ITEMS NOT SHOWN
13 SEALANT
14 OIL, 20W50
200 KIT, SEAL

* - PARTS INCLUDED IN 200 KIT, SEAL

TRACTOR - - MODEL NUMBER 944.101081

HYDRO GEAR TRANSAXLE - - MODEL NUMBER G7-BCBB-1XDC-1FCA

KEY NO.	PART NO.	DESCRIPTION	KEY NO.	PART NO.	DESCRIPTION
57	169870	Ring, Retaining 1.575 Internal	(71)		Ring, Retaining .625 External
60	421195	Bearing, Thrust	(90)		Ring, Retaining 2.06 Internal
64	421196	Assembly, Block	(96)		Seal, Lip 25 X 52 X 10 Tc (Gray)
		Block	(130)		Tube, Connecting
		Spring	(132)		O-Ring, -137, .103 X 2.050
		Seat Washer	(155)		Ring, Spiral Ret .875
		Piston	201	421220	Kit, Center Section, Lh, Chrg
65	173159	Bearing, Thrust Ball 30 X 52 X 13	20		Center Section, Lh, Chrg
69	421197	Assembly, Block	(22)		Plate, Bypass
		Block	24		Check Plug
		Spring	25		Check Plug
		Seat Washer	(26)		Seal, Plug 1.250 X .250
		Piston	(27)		Hfhcs 3/8-16 X 1.5 (Patch) Brg, Jrnl
70	170404	Washer, .63 X 1.0 X .05	135		Ball, Steel 7/16"
71	170405	Ring, Retaining .625 External	136		Spring, Relief .42 X .75
72	421198	Gear, 14t	137		Pin, Spring .125 X .875
73	421199	Shaft, Motor	202	421221	Kit, Charge Relief
74	170433	Washer, .72 X 1.16 X .04	135		Ball Steel 7/16"
80	170418	Washer, .5 X 1.0 X .03	136		Spring, Relief .42 X .75
81	421200	Gear, 45t	137		Pin, Spring .125 X .875
82	421201	Gear, 11t	203	421222	Kit, Charge
83	170394	Pin, Jackshaft	(131)		Gerotor Assembly (1.9cc/Rev)
90	169539	Ring, Retaining 2.06 Internal	(132)		O-Ring 137 .103 X 2.050
91	421202	GEar, 60t	(133)		Cover, Charge Pump
92	421203	Spacer, 1.04 X 1.65 X .22	(134)		Screw, Hex Flange 1/4-20 X .75
94	421204	Shaft, Axle 1.00 X 14.48, Keyed	207	422128	Kit, Fan/Pulley
95	169535	Bearing, Ball 1.0 X 52 X 15	(120)		Fan Recess 7.0 (10 Blade)
96	161157	Seal, Lip 25 X 52 X 10 Tc (Gray)	(121)		Pulley 3.86 Inch
120	421205	Fan, Recess 7.0 (10 Blade)	(122)		Hex Lock Nut 1/2-20 (With Patch)
121	422126	Pulley 3.86 Inch	(123)		Washer, Slotted
122	150794	Hex Lock Nut 1/2-20 (With Patch)	210	421224	Kit, Input Shaft
123	199658	Washer, Slotted			Shaft, Input
130	421207	Tube, Connecting			Brg, Ball 17 X 40 X 12 OpeN 6203
131	169531	Geroter Assembly (1.9cc/Rev)			Ring, Ret Wire .561 Id
132	421208	O-Ring, -137, .103 X 2.050	212	178329	Kit, Brake-Yoke
133	421209	Cover, Charge Pump			Bolt, Square Head
134	178343	Screw, Hex Flange 1/4-20 X .75			Brake-Yoke
140	421210	Spacer, .320 X 1.005 X .179	214	421225	Kit, G700 Ros
142	421211	Shcs 5/16-24 X 1 Patch	141		Assembly Rtn, Neutral
147	421212	Spring, Extention Rtn-44 Lbs	156		Retainer, Switch
152	421213	Gear, Bevel 14t Spline Id	157		Rivet, 5/32
153	421214	Gear, Bevel 10t	158		Switch, Rcs
154	421215	Pin, .499 X 1.20	215	421226	Kit, G700 Rtn/Ros
155	421216	Ring, Spiral Ret .875	44		Arm, Control
170	142883	Puck, Brake	(46)		Screw, 5/16-18 X 1
171	421217	Rotor, Brake	145		Assembly, Rtn
172	142882	Plate, Puck	146		Washer, .343 X 1.500 X .062
175	142892	Bolt, Hex Head 1/4-20 X 1 W/Patch	157		Rivet, 5/32
176	170410	Bolt, Hex Head 1/4-20 X 2 W/Patch	159		Clip, Actuator
177	170409	Pin, Brk .31 X .73 Plated	216	421227	Kit, Breather
178	170417	Spring, Comp Brake Anti-Drag			Fitting, 9/16 Sae
179	178330	Arm, Brake			Cap, Barbed Vent
181	170415	Nut, Castle 5/16-24 Pl	217	421228	Kit, Bypass
182	170416	Pin, Cotter 3/32 X 3/4	34		Bypass Arm
183	170411	Spacer, .26 X .57 X .87	(35)		Retaining Ring
184	142884	Washer, .27 X .88 X .12	218	421229	Kit, Filter Guard
185	178335	Spring, Brake Arm Bias	105		Hfhcs 1/4-20 X .75
191	421218	Tube .16 X .28 X 9.25	106		Guard, Filter, Lh
200	421219	Kit, Seal	219	422129	Kit, Damper
		Pin .25 X .375	115		Damper
(10)		Seal, Lip .625 X 1.0	116		Bracket
(26)		Seal, Plug 1.250 X .250	117		Stud, Threaded Ball
(30)		Seal, Lip .375 X .75 X .25	118		Washer, 5/16 Lock
(31)		Ring, Retaining .375 External	119		Nut, Hex 5/16-18
(33)		Ring, Retaining .750 Internal			
(35)		Ring, Retaining .375 External			
(41)		Seal, Lip 18 X 32 X 7			
(46)		Twhcs 5/16-24 X 1.00 (Patch)			
(56)		Seal, Lip 17 X 40 X 7			
(57)		Ring, Retaining 1.575 Internal			

*() * Indicates that part is listed elsewhere and is available as an individual part.

NOTE: All component dimensions given in U.S. inches
1 inch = 25.4 mm

TRACTOR - - MODEL NUMBER 944.101081
KOHLER ENGINE-MODEL NUMBER KT745, TYPE NUMBER 3016

CRANKCASE GROUP
KT715, 725, 730, 735, 740, 745

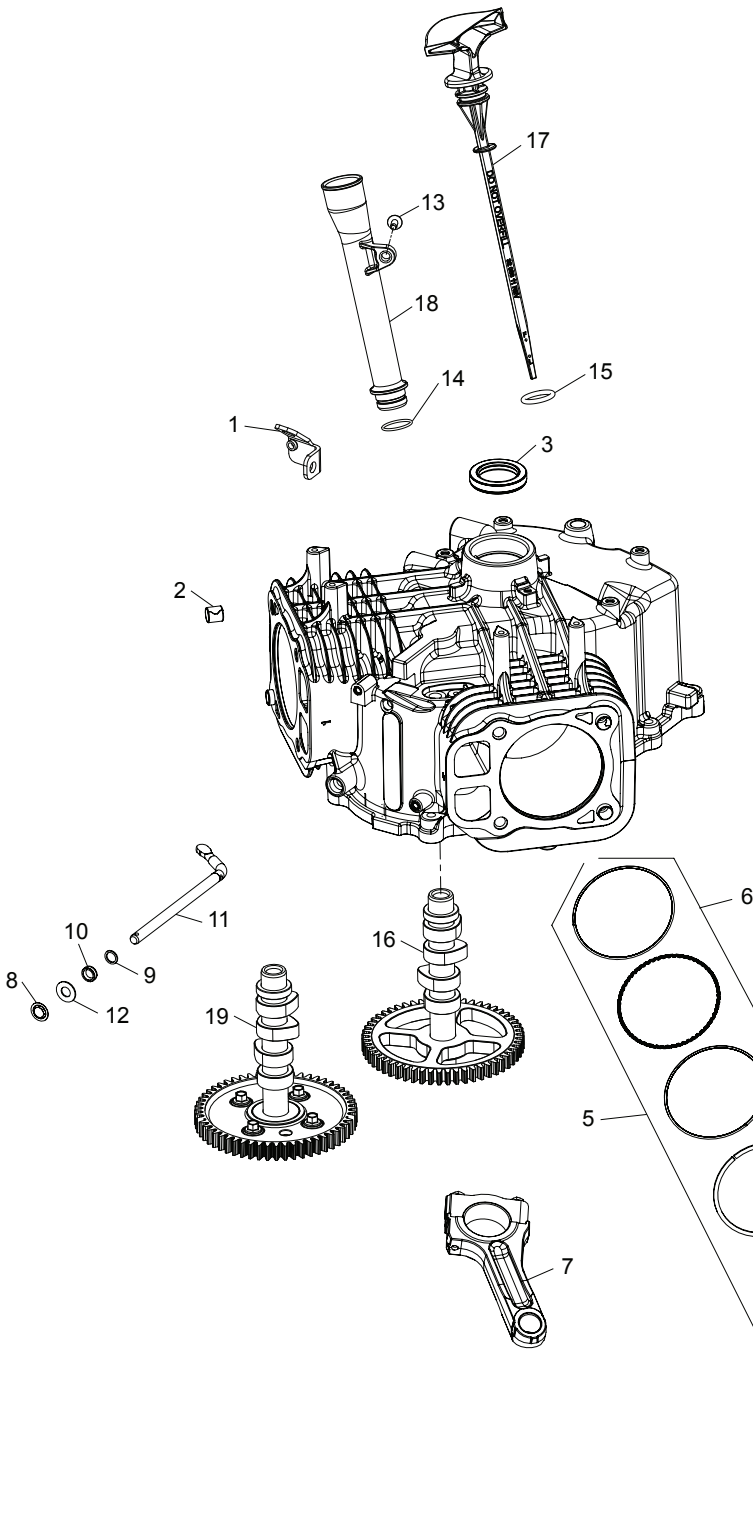

CRANKSHAFT GROUP:
KT710,715,725,730,735,740,745

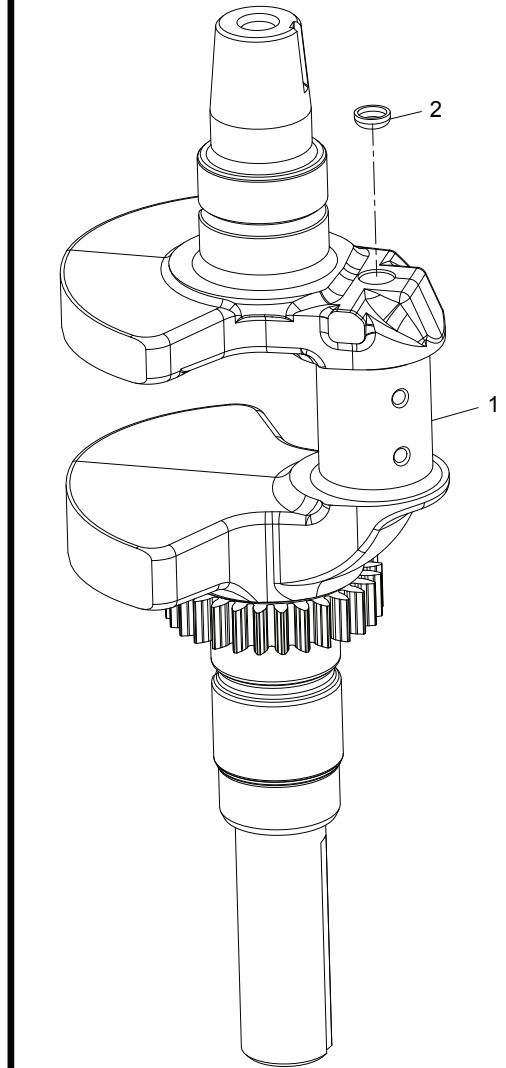

ILLUSTRATIONS ARE REPRESENTATIVE AND ARE NOT INTENDED TO SHOW ALL DETAILS FOR EACH COMPONENT

**TRACTOR - - MODEL NUMBER 944.101081
 KOHLER ENGINE-MODEL NUMBER KT745, TYPE NUMBER 3016**

KEY NO.	PART NO.	DESCRIPTION-QTY
------------	-------------	-----------------

CRANKCASE GROUP 2-32-15

1	24 126 243-S	LIFTING STRAP - 1
2	24 380 16-S	PIN, LOCATING - 6
3	24 032 19-S	SEAL, OIL (HELIX LIP) - 1
4	24 018 01-S	RETAINER, PISTON PIN - 4
5	25 108 01-S	RING SET (STD) - 2
5	25 108 02-S	RING SET (+0.08) - 2
5	25 108 03-S	RING SET (+0.25) - 2
5	25 108 04-S	RING SET (+0.50) - 2
6	25 874 13-S	PISTON KIT, 725CC (STD) - 2
6	25 874 15-S	PISTON KIT, 725CC (0.08) - 2
6	25 874 16-S	PISTON KIT, 725CC (+0.25) - 2
6	25 874 17-S	PISTON KIT, 725CC (+0.50) - 2
7	24 067 28-S	ROD, ASSY CONNECTING (STD)- (#2406730S) - 2
7	24 067 29-S	Rod Assy, Connecting U/S (.010") (.25 mm) -USE 24 067 31-S - 2
8	24 018 09-S	RETAINER, RING - 1
9	24 468 15-S	WASHER, FLAT 11/32" - 1
10	28 032 09-S	SEAL, GOVERNOR CROSS SHAFT - 1
11	24 144 38-S	SHAFT, GOVERNOR CROSS - 1
12	M-931010-S	WASHER, FLAT 9 MM - 1
13	25 086 398-S	SCREW, THREAD FORMING - 1
14	12 153 07-S	O-RING - 1
15	25 153 09-S	O-RING - 1
16	32 010 07-S	CAMSHAFT ASSEMBLY - 1
17	32 038 12-S	DIPSTICK ASSEMBLY - 1
18	32 123 14-S	TUBE ASSEMBLY, OIL FILL - 1

Crankshaft Group 1-32-12

1	32 014 327-S	CRANKSHAFT ASSY (1.000" x 3.16") - 1
2	52 139 09-S	PLUG, CUP - 1

NOTE: All component dimensions given in U.S. inches
 1 inch = 25.4 mm

TRACTOR - - MODEL NUMBER 944.101081
KOHLER ENGINE-MODEL NUMBER KT745, TYPE NUMBER 3016

LUBRICATION GROUP
KT715, 725, 730, 735, 740, 745

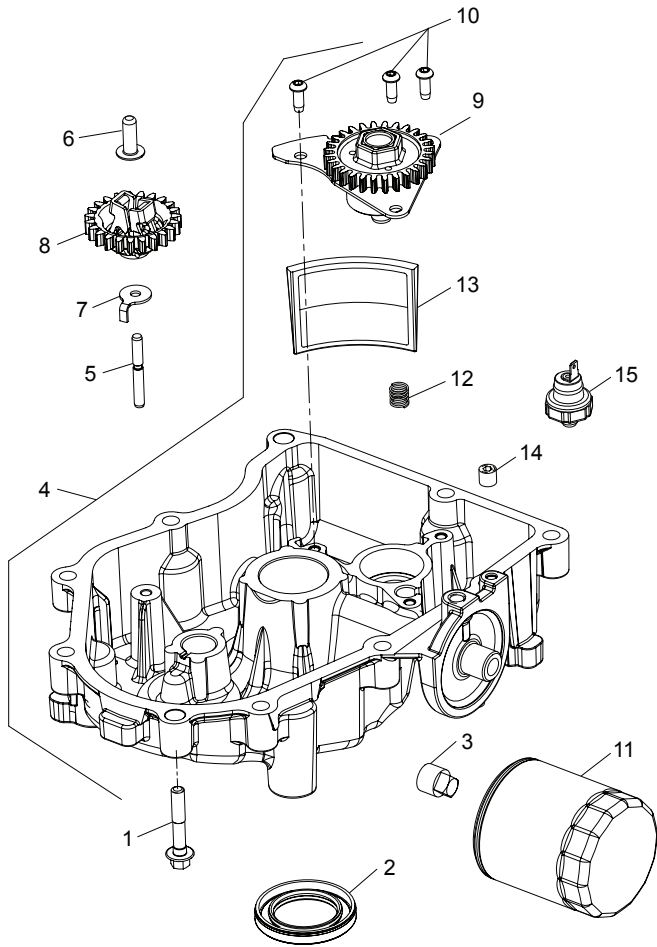

STARTING GROUP
KT715, 725, 730, 735, 740, 745

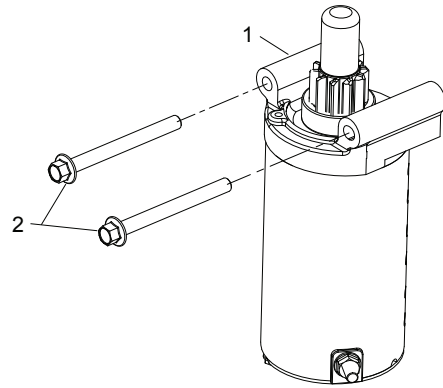

IDENTIFICATION GROUP
KT715, 725, 730, 735, 740, 745

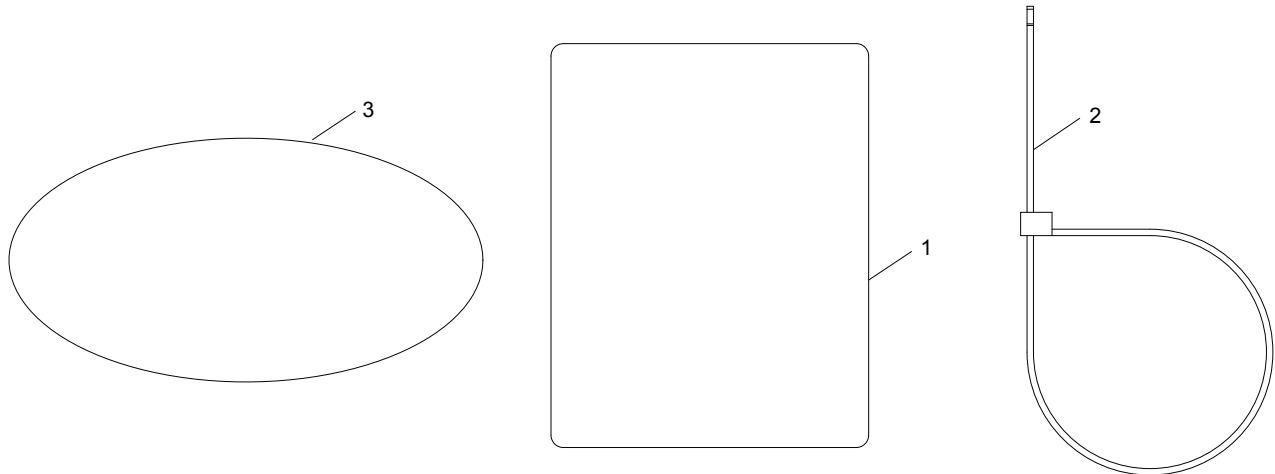

ILLUSTRATIONS ARE REPRESENTATIVE AND ARE NOT INTENDED TO SHOW ALL DETAILS FOR EACH COMPONENT

**TRACTOR - - MODEL NUMBER 944.101081
 KOHLER ENGINE-MODEL NUMBER KT745, TYPE NUMBER 3016**

KEY NO.	PART NO.	DESCRIPTION-QTY
LUBRICATION GROUP 3-24-45		
1	24 086 17-S	SCREW, FLG M8X1.25X45 - 10
2	25 032 06-S	SEAL, OIL - 1
3	25 139 57-S	PLUG, SQ HD PIPE 3/8" - 2
4	32 199 17-S	PAN ASSEMBLY, OIL - 1
5	12 144 02-S	SHAFT, GOVERNOR GEAR - 1
6	12 380 01-S	PIN, GOVERNOR REGULA- TING - 1
7	24 448 02-S	TAB, LOCKING 1
8	32 310 02-S	KIT, GOVERNOR GEAR - 1
9	24 393 51-S	PUMP ASSEMBLY, OIL-USE 24 393 53-S - 1
10	25 086 414-S	SCREW, BUTTON HEAD - 3
11	52 050 02-S	OIL FILTER - 1
12	32 089 06-S	SPRING, COMPRESSION - 1
13	32 162 06-S	SCREEN, OIL - 1
14	25 139 60-S	PLUG, CTSK PIPE 1/8" - 1

STARTING GROUP 7-32-11

1	32 098 04-S	ELECTRIC STARTER-BENDIX DRIVE - 1
2	M-851080-S	SCREW, FLG M8X1.25X80 - 2

IDENTIFICATION GROUP 12-32-53

1	25 113 70-S	LABEL, CLEAR LAMINATION - 1
2	25 454 05-S	TIE - 1
3	32 113 108-S	LABEL, 22HP - 1

NOTE: All component dimensions given in U.S. inches
 1 inch = 25.4 mm

TRACTOR - - MODEL NUMBER 944.101081
KOHLER ENGINE-MODEL NUMBER KT745, TYPE NUMBER 3016

CYLINDER HEAD GROUP
 KT715, 725, 730, 735, 740, 745

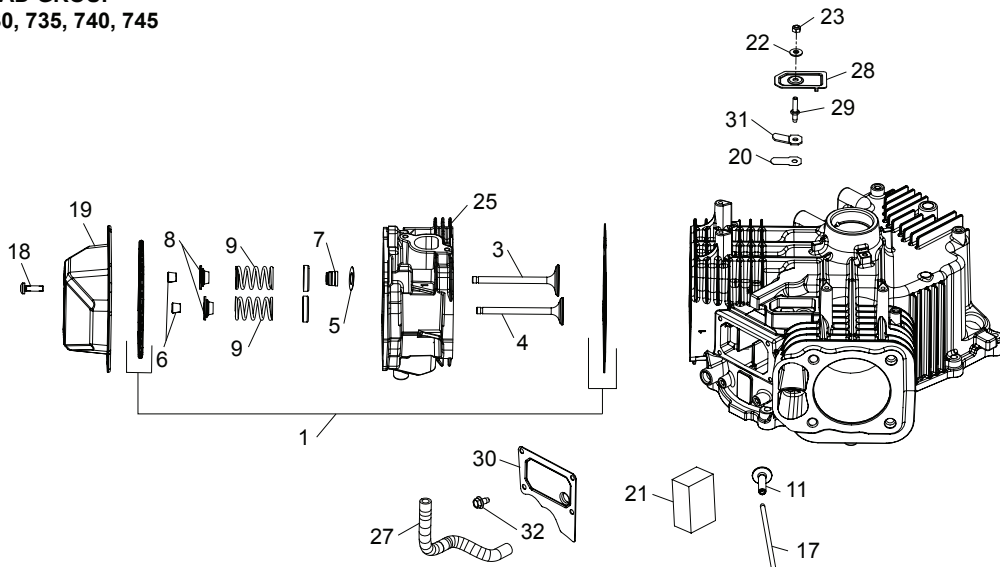

EXHAUST GROUP
 KT715, 725, 730, 735, 740, 745

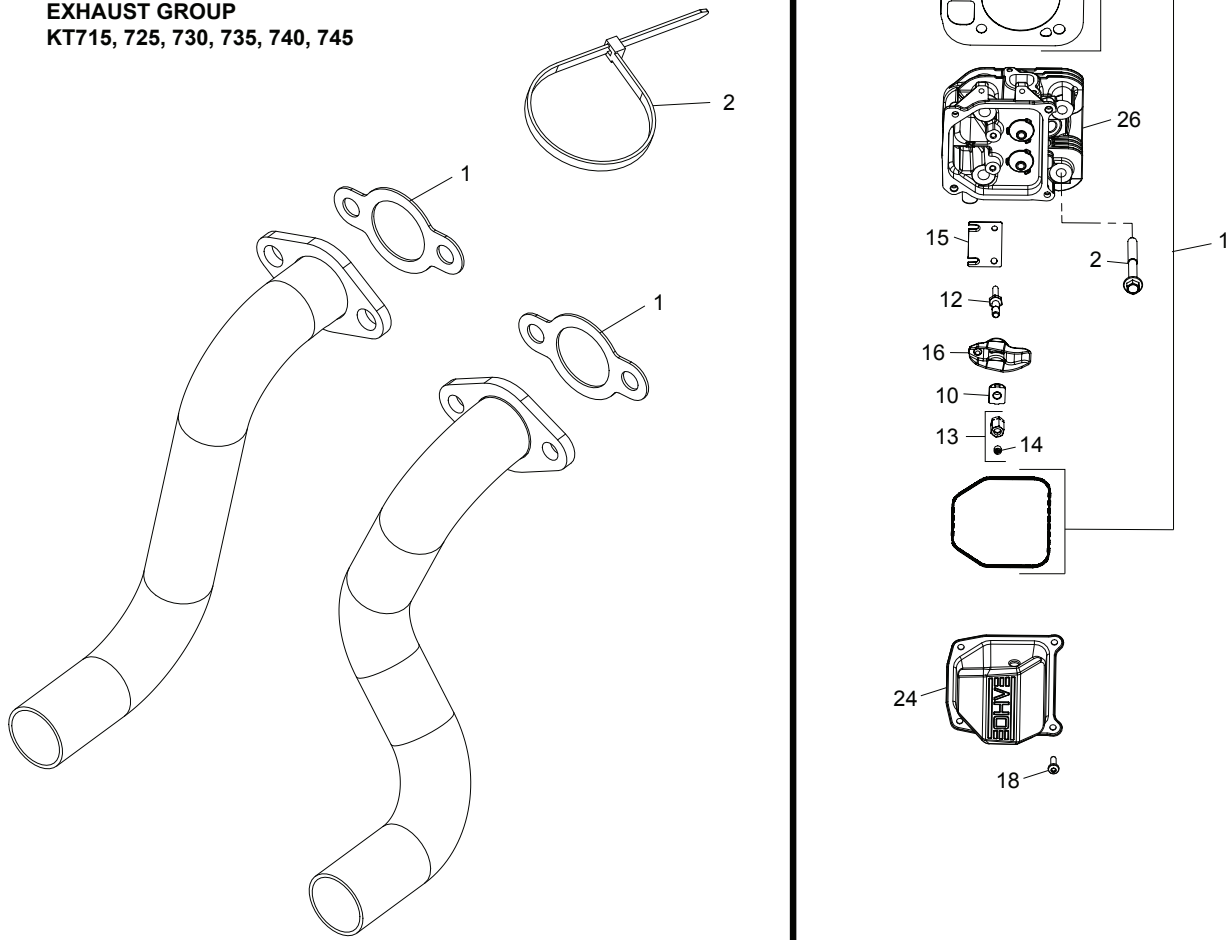

ILLUSTRATIONS ARE REPRESENTATIVE AND ARE NOT INTENDED TO SHOW ALL DETAILS FOR EACH COMPONENT

TRACTOR - - MODEL NUMBER 944.101081
KOHLER ENGINE-MODEL NUMBER KT745, TYPE NUMBER 3016

KEY NO.	PART NO.	DESCRIPTION-QTY
CYLINDER HEAD/BREATHER GROUP 4-32-14		
1	32 841 02-S	KIT, CYLINDER HEAD GASKET - 2
2	62 086 08-S	SCREW, FLG M10X1.5X90 - 8
3	32 017 01-S	VALVE, INTAKE - 2
4	32 016 01-S	VALVE, EXHAUST - 2
5	275067-S	SPACER (.010") - 2
6	12 755 03-S	KIT, RETAINER - 8
7	25 032 14-S	SEAL, VALVE BAND - 2
8	25 173 28-S	CAP, VALVE SPRING - 4
9	32 089 05-S	SPRING, VALVE - 4
10	25 599 01-S	PIVOT, ROCKER ARM - 4
11	32 019 02-S	TAPPET - 4
12	32 072 04-S	STUD, ROCKER - 4
13	32 100 05-S	HEX NUT ASSEMBLY - 4
14	25 086 168-S	SCREW, SET - 4
15	32 146 09-S	PLATE, GUIDE - 2
16	32 186 03-S	ARM, ROCKER - 4
17	32 411 04-S	ROD, PUSH - 4
18	25 086 374-S	SCREW, PAN HEAD - 8
19	25 096 09-S	COVER, ROCKER STAMPED STEEL - 1
20	12 402 02-S	REED, BREATHER - 1
21	32 050 06-S	FILTER, BREATHER - 1
22	32 468 01-S	WASHER, SEALING - 1
23	M-547050-S	NUT, LOCK M5X.8 - 1
24	25 096 11-S	COVER, ROCKER STAMPED STEEL - 1
25	32 318 21-S	HEAD, ASSEMBLY CYLINDER (#1) - 1
26	32 318 22-S	HEAD, ASSEMBLY CYLINDER (#2) - 1
27	25 326 62-S	HOSE, BREATHER - 1
28	32 096 16-S	OVER, BREATHER REED - 1
29	32 072 05-S	STUD - 1
30	16 096 02-S	COVER, BREATHER MEDIA - 1
31	66 018 04-S	RETAINER, REED - 1
32	25 086 400-S	SCREW, THREAD FORMING - 4

EXHAUST GROUP 4-32-14

1	24 041 49-S	GASKET, EXHAUST MANIFOLD (km)
2	25 454 05-S	TIE, WIRE (KM) (CKY)

NOTE: All component dimensions given in U.S. inches
1 inch = 25.4 mm

TRACTOR - - MODEL NUMBER 944.101081
KOHLER ENGINE-MODEL NUMBER KT745, TYPE NUMBER 3016

IGNITION GROUP
KT715, 725, 730, 735, 740, 745

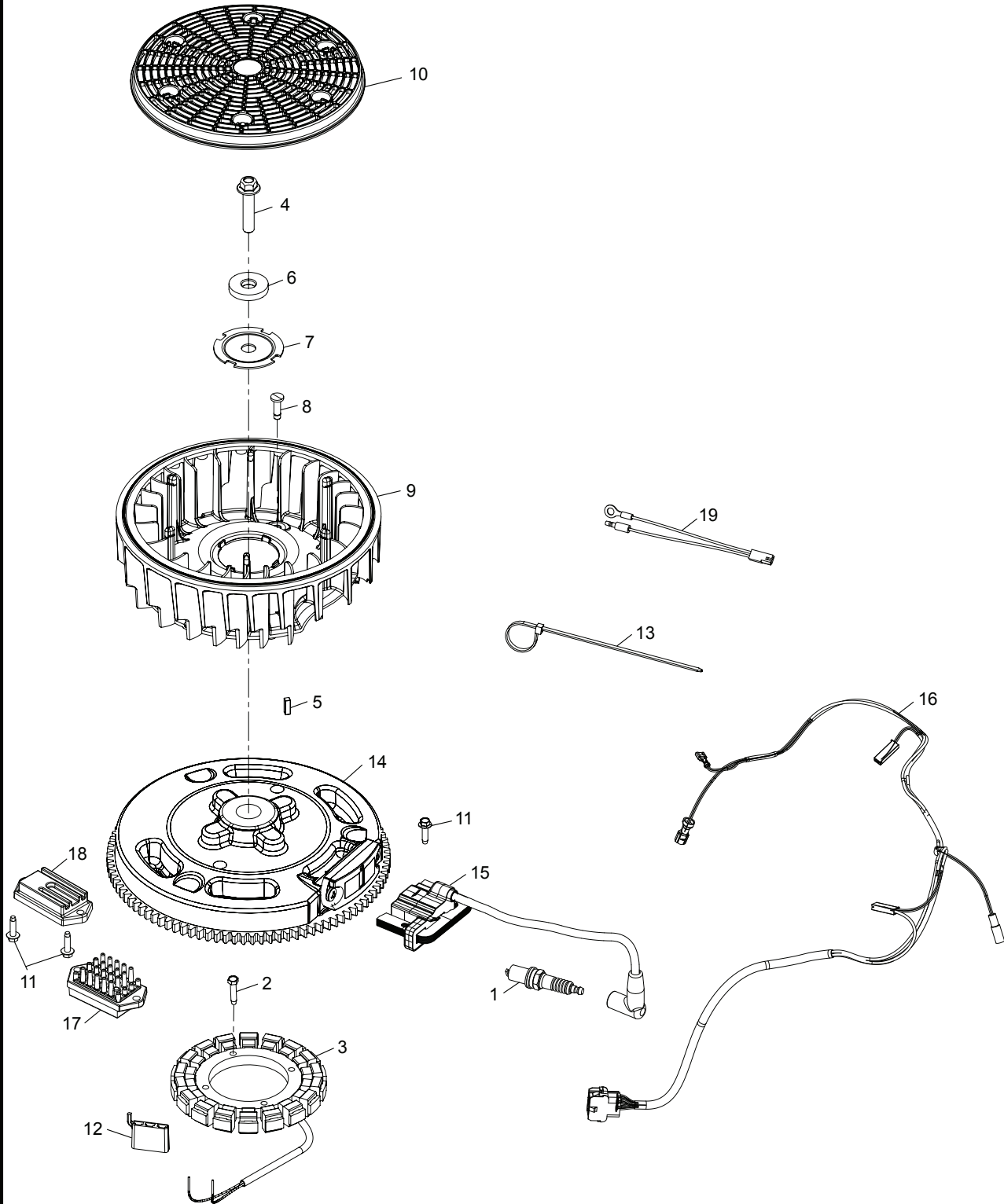

ILLUSTRATIONS ARE REPRESENTATIVE AND ARE NOT INTENDED TO SHOW ALL DETAILS FOR EACH COMPONENT

**TRACTOR - - MODEL NUMBER 944.101081
 KOHLER ENGINE-MODEL NUMBER KT745, TYPE NUMBER 3016**

KEY NO.	PART NO.	DESCRIPTION-QTY
IGNITION/CHARGING GROUP 5-32-122		
1	25 132 12-S	PLUG, SPARK (PRO SERIES) - 2
2	25 086 402-S	SCREW, THREAD FORMING - 2
3	237878-S	KIT, 15 / 20 AMP STATOR - 1
4	25 086 361-S	SCREW, HEX FLANGE - 1
5	25 340 04-S	KEY, SQUARE - 1
6	25 468 09-S	WASHER, FLAT - 1
7	20 146 05-S	PLATE, FAN MOUNTING - 1
8	32 018 03-S	RETAINER, FLYWHEEL FAN - 2
9	32 157 04-S	FAN - 1
10	32 162 03-S	SCREEN, GRASS - 1
11	25 086 399-S	SCREW, THREAD FORMING - 4
12	25 155 41-S	CONNECTOR - 1
13	25 454 03-S	TIE, WIRE - 1
14	32 025 25-S	FLYWHEEL ASSEMBLY - 1
15	32 584 06-S	MODULE, IGNITION - 2
16	32 176 33-S	HARNESS, WIRING ASSEMBLY - 1
18	41 403 10-S	REGULATOR/RECTIFIER - 1
19	32 518 02-S	LEAD, JUMPER - 1

NOTE: All component dimensions given in U.S. inches
 1 inch = 25.4 mm

TRACTOR - - MODEL NUMBER 944.101081
KOHLER ENGINE-MODEL NUMBER KT745, TYPE NUMBER 3016

BLOWER HOUSING GROUP
 KT715, 725, 730, 735, 740, 745

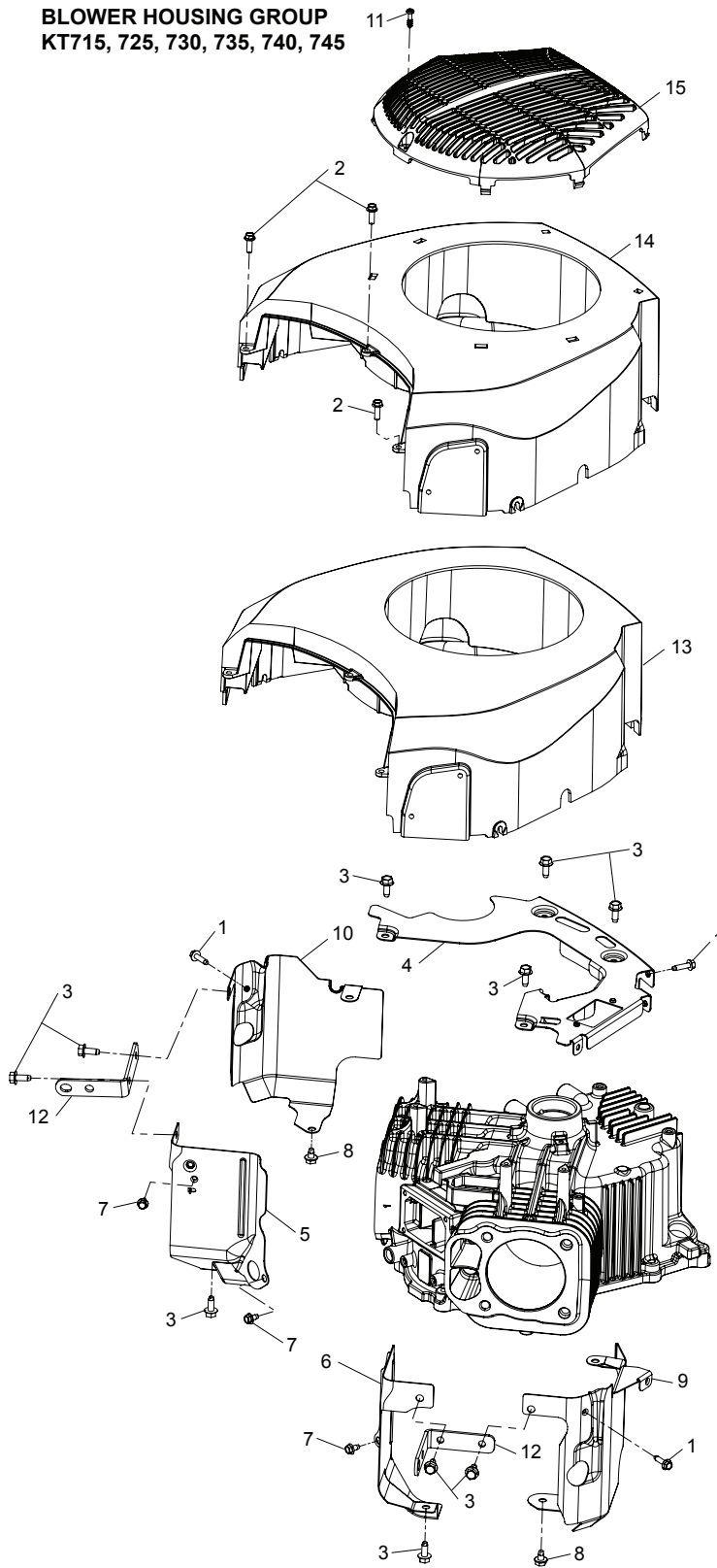

AIR INTAKE GROUP
 KT 715, 725, 730, 735, 740, 745

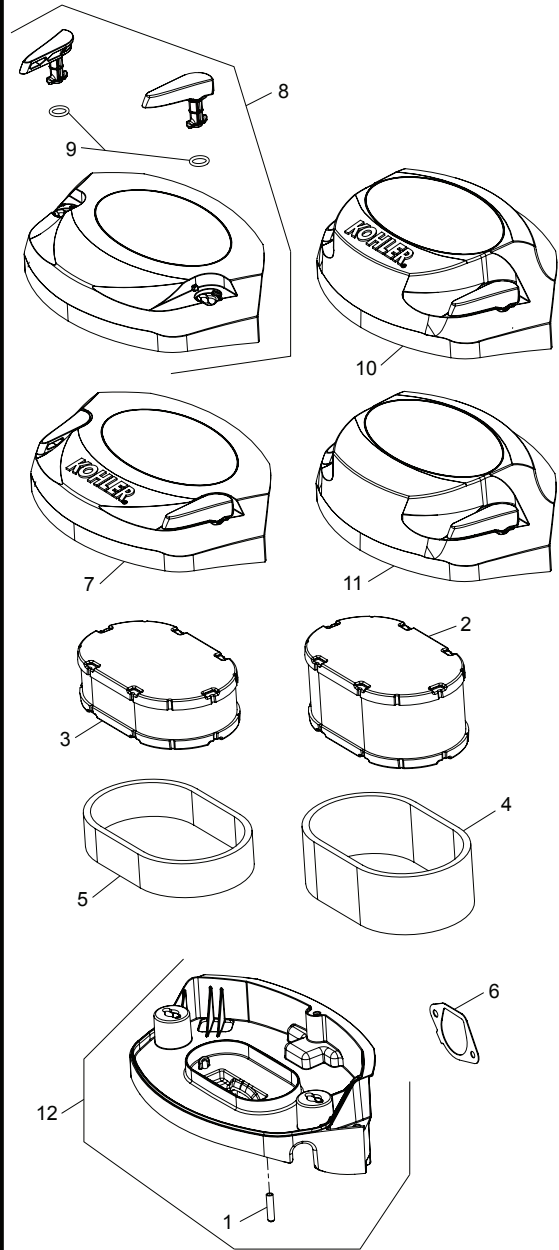

ILLUSTRATIONS ARE REPRESENTATIVE AND ARE NOT INTENDED TO SHOW ALL DETAILS FOR EACH COMPONENT

TRACTOR - - MODEL NUMBER 944.101081
KOHLER ENGINE-MODEL NUMBER KT745, TYPE NUMBER 3016

KEY NO.	PART NO.	DESCRIPTION-QTY
BLOWER HOUSING GROUP 6-32-23		
1	25 086 399-S	SCREW, THREAD FORMING - 6
2	25 086 450-S	SCREW, HI-LOW - 3
3	25 086 397-S	SCREW, THREAD FORMING - 8
4	32 146 15-S	PLATE, BACKING - 1
5	32 063 19-S	BAFFLE, VALLEY #1 - 1
6	32 063 20-S	BAFFLE, VALLEY #2 - 1
7	25 086 400-S	SCREW, THREAD FORMING - 2
8	25 086 406-S	SCREW, THREAD FORMING - 2
9	32 063 17-S	BAFFLE, LEFT BARRE - 1
10	32 063 18-S	BAFFLE, RIGHT BARREL - 1
12	32 445 01-S	STRAP, LIFTING - 2
13	32 027 16-S	HOUSING, BLOWER - 1

AIR INTAKE GROUP 10-32-13

1	25 173 09-S	CAP, MASKING - 1
3	32 083 09-S	ELEMENT, AIR FILTER - 1
6	32 041 04-S	GASKET, AIR CLEANER BASE - 1
7	32 096 20-S	COVER ASSEMBLY, AIR CLEANER - 1
9	25 153 15-S	O-RING - 2
12	32 094 13-S	BASE ASSEMBLY, AIR CLEANER - 1

NOTE: All component dimensions given in U.S. inches
1 inch = 25.4 mm

TRACTOR - - MODEL NUMBER 944.101081
KOHLER ENGINE-MODEL NUMBER KT745, TYPE NUMBER 3016

FUEL SYSTEM GROUP
KT715, 725, 730, 735, 740, 745

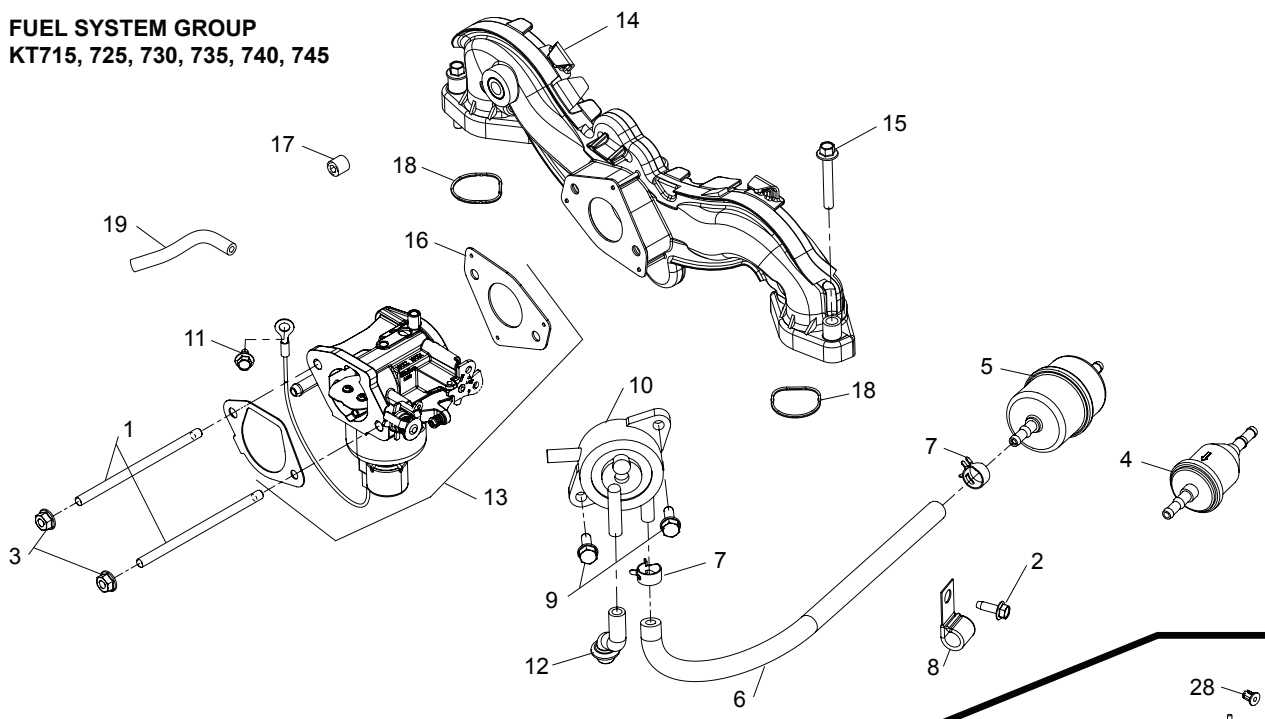

ENGINE CONTROL GROUP
KT715, 725, 730, 735, 740, 745

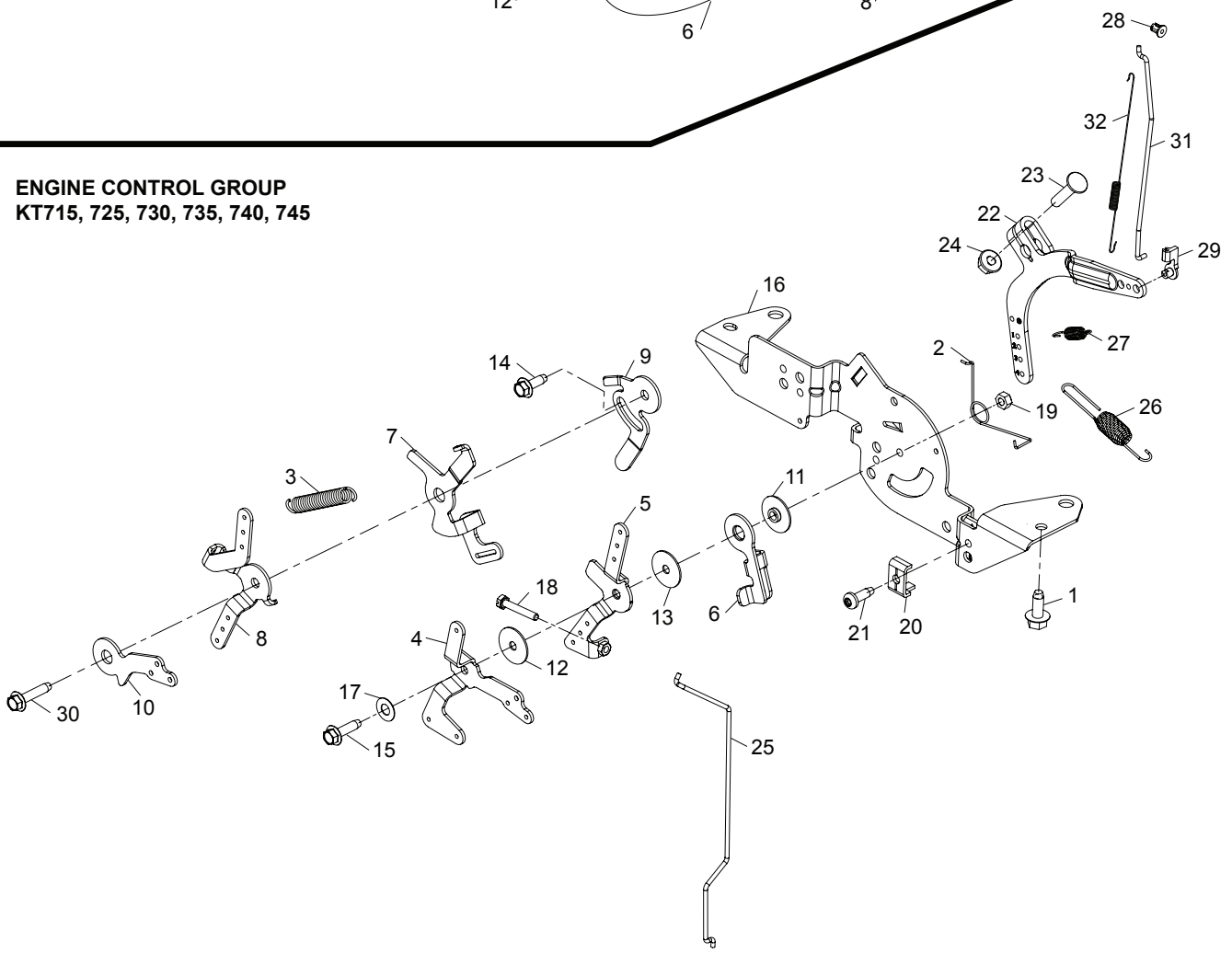

ILLUSTRATIONS ARE REPRESENTATIVE AND ARE NOT INTENDED TO SHOW ALL DETAILS FOR EACH COMPONENT

TRACTOR - - MODEL NUMBER 944.101081
KOHLER ENGINE-MODEL NUMBER KT745, TYPE NUMBER 3016

KEY NO.	PART NO.	DESCRIPTION-QTY
FUEL SYSTEM GROUP 8-32-86		
1	25 072 25-S	STUD - 2
2	25 086 398-S	SCREW, THREAD FORMING - 1
3	M-641060-S	NUT, FLG M6X1.0 - 2
5	24 050 13-S	FILTER, FUEL - 1
6	25 111 34-S	HOSE, LW PERM. FUEL 24.00"-USE 25 111 81-S - 1
7	25 237 37-S	CLAMP SPRING HOSE - 4
8	47 154 01-S	CLIP, CABLE - 1
9	24 086 12-S	SCREW, TAP M6X1.7X18 - 2
10	24 393 16-S	PUMP, FUEL - 1
11	25 086 400-S	SCREW, THREAD FORMING - 1
12	32 326 08-S	HOSE, PULSE PUMP - 1
13	32 853 43-S	KIT, CARBURETOR - 1
14	24 164 91-S	KIT, INTAKE MANIFOLD - 1
15	M-651040-S	SCREW, FLG M6X1.0X40 - 4
16	24 041 52-S	GASKET, CARBURETOR - 1
17	25 139 60-S	PLUG, CTSK PIPE 1/8" - 1
18	24 153 27-S	O-RING, INTAKE PORT - 2

ENGINE CONTROLS GROUP 9-32-34

1	25 086 397-S	SCREW, THREAD FORMING - 4
2	24 089 03-S	SPRING, CHOKE RETURN - 1
4	24 090 05-S	LEVER, CHOKE - 1
5	24 090 13-S	LEVER, THROTTLE CONTROL - 1
6	24 090 47-S	LEVER, THROTTLE ACTUATOR - 1
11	24 112 27-S	SPACER, CONTROL ASSEMBLY - 1
12	24 468 01-S	WASHER, FLAT 5.5 MM - 1
13	24 468 20-S	WASHER, FLAT 5 MM - 1
14	25 086 398-S	SCREW, THREAD FORMING - 1
15	25 086 399-S	SCREW, THREAD FORMING - 1
16	32 126 04-S	BRACKET, CONTROL - 1
17	41 468 03-S	WASHER, SPRING 1/4" - 1
18	M-403025-S	SCREW, SLT HD CAP M4X0.7X25 - 1
19	M-547050-S	NUT, LOCK M5X.8 - 1
20	12 237 01-S	CLAMP, CABLE - 2
21	25 086 405-S	SCREW, THREAD FORMING - 2
22	24 090 57-S	LEVER, GOVERNOR - (#2409069S) - 1
23	24 211 03-S	BOLT, RD HD SQ NECK M6X1.0X25 - 1
24	M-641060-S	NUT, FLG M6X1.0 - 1
25	24 079 22-S	LINKAGE, CHOKE - 1
26	24 089 25-S	SPRING, GOVERNOR (ORANGE) - 1
27	24 089 55-S	SPRING, GOVERNED IDLE - 1
28	25 158 08-S	BUSHING, LINKAGE RETAINING - 1
29	25 158 11-S	BUSHING, THROTTLE LINKAGE - 1
31	32 079 01-S	LINKAGE, THROTTLE - 1
32	32 089 07-S	SPRING, LINKAGE - 1

NOTE: All component dimensions given in U.S. inches
1 inch = 25.4 mm

SERVICE NOTES

SERVICE NOTES

SERVICE NOTES

TRACTEUR - - N° DE MODÈLE 944.101081
MOTEUR "KOHLER" - NO. DE MODELE KT745, NO. DE TYPE 3016

NO. DE REF. DE PIÈCE
DESCRIPTION - QTY

GRUPE DE SYSTÈMES DE CARBURANT 8-32-86

1	25 072 25-S	CARBURATEUR GOUJON - 2
2	25 086 398-S	VIS - 1
3	M-641060-S	ECROU M6X1.0 - 2
5	24 050 13-S	FILTRE À CARBURANT - 1
6	25 111 34-S	CONDUITE DE CARBURANT 24.00"-USE 25 111 81-S - 1
7	25 237 37-S	COLLIER DE FLEXIBLE - 4
8	47 154 01-S	ATTACHE DE CÂBLE - 1
9	24 086 12-S	VIS M6X1.7X18 - 2
10	24 393 16-S	POMPE À CARBURANT - 1
11	25 086 400-S	VIS - 1
12	32 326 08-S	PULSE FLEXIBLE DE LA POMPE - 1
13	32 853 43-S	KIT CARBURATEUR - 1
14	24 164 91-S	D'ADMISSION KIT - 1
15	M-651040-S	VIS M6X1.0X40 - 4
16	24 041 52-S	JOINT- 1
17	25 139 60-S	BOUCHON 1/8" - 1
18	24 153 27-S	JOINT TORIQUE - 2

GRUPE DE CONTRÔLES MOTEUR 9-32-34

1	25 086 397-S	VIS - 4
2	24 089 03-S	RESSORT DE RAPPEL DU STARTER - 1
4	24 090 05-S	LEVIER DE STARTER - 1
5	24 090 13-S	LEVIER D'ACCELERATEUR - 1
6	24 090 47-S	ACTIONNEUR D'ACCELERATEUR DU LEVIER - 1
11	24 112 27-S	ENSEMBLE DE CONTRÔLE DE L'ENTRETOISE - 1
12	24 468 01-S	RONDELLE PLATE 5.5 MM - 1
13	24 468 20-S	RONDELLE PLATE 5 MM - 1
14	25 086 398-S	VIS - 1
15	25 086 399-S	VIS - 1
16	32 126 04-S	SUPPORT DE COMMANDE - 1
17	41 468 03-S	RONDELLE DE RESSORT 1/4" - 1
18	M-403025-S	VIS M4X0.7X25 - 1
19	M-547050-S	ECROU M5X8 - 1
20	12 237 01-S	COLLIER DE CÂBLE - 2
21	25 086 405-S	VIS - 2
22	24 090 57-S	LEVIER- (#2409069S) - 1
23	24 211 03-S	BOULON M6X1.0X25 - 1
24	M-641060-S	ECROU M6X1.0 - 1
25	24 079 22-S	TRINGLERIE STARTER - 1
26	24 089 25-S	RESSORT (ORANGE) - 1
27	24 089 55-S	RESSORT DE RALENTI - 1
28	25 158 08-S	TRINGLERIE DE RETENUE DE LA BAGUE - 1
29	25 158 11-S	LA TRINGLERIE DE LA MANETTE D'ACCELERATION
31	32 079 01-S	LA BAGUE - 1
32	32 089 07-S	RESSORT DE TRINGLERIE - 1

REMARQUE: Toutes les dimensions de composant sont données en pouces E.-U. --1 pouce = 25,4 mm

TRACTEUR - - NÚMERO DE MODELO 944.101081 - NO. DE MODELO KT745, NO. DE TIPO 3016

GRUPE DE SISTEMA DE CARBURANTE

KT715, 725, 730, 735, 740, 745

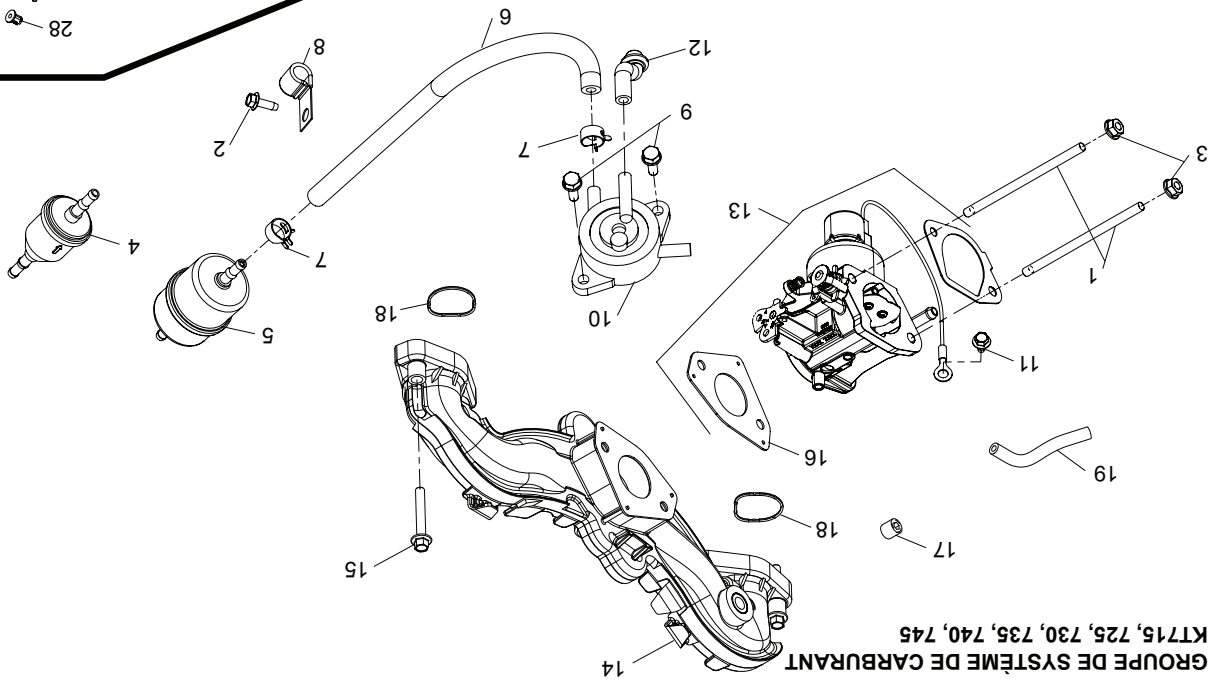

GRUPE DE CONTROL DE MOTOR

KT715, 725, 730, 735, 740, 745

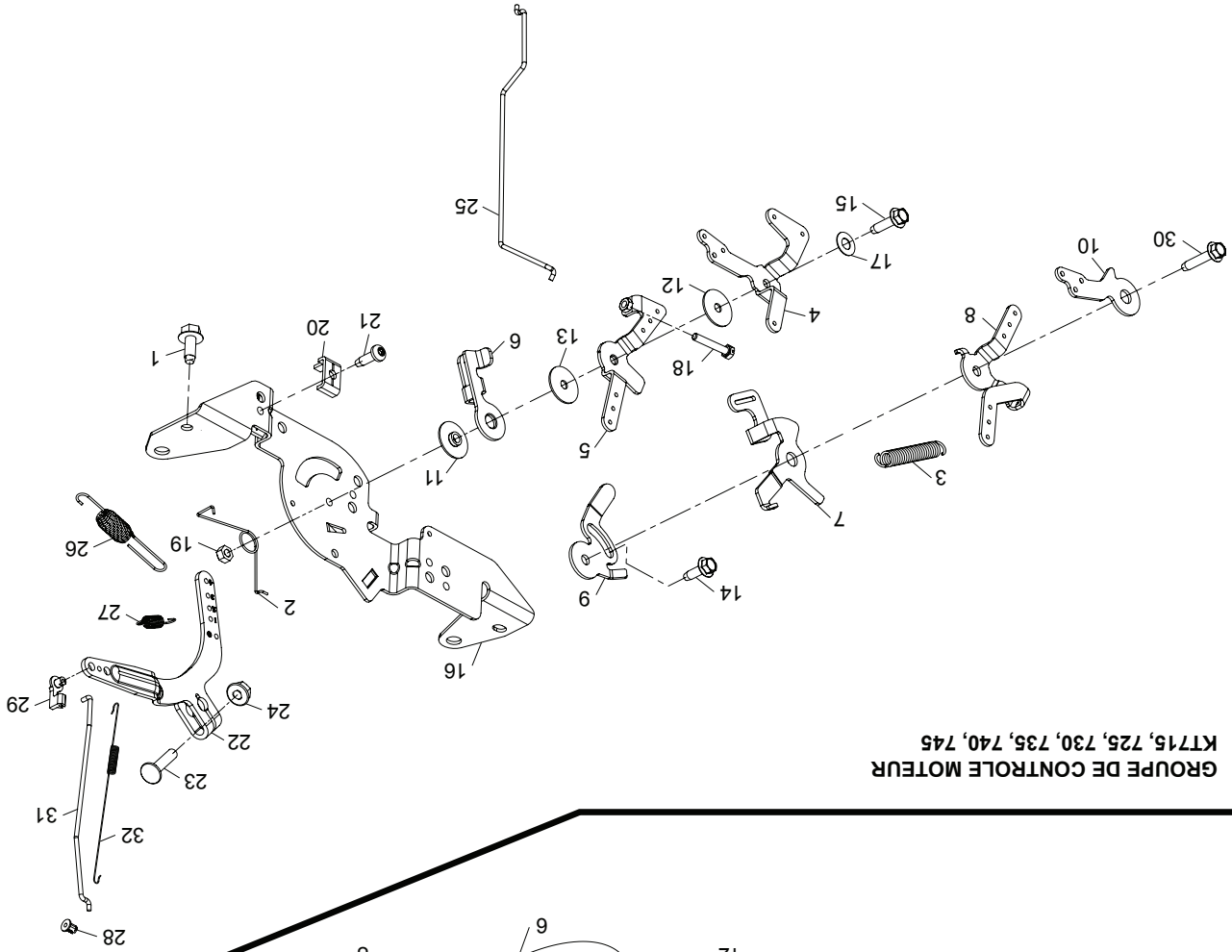

LES ILLUSTRATIONS SONT ET NE SONT PAS POUR BUT DE MONTRER TOUS LES DÉTAILS POUR CHAQUE COMPOSANT

TRACTEUR - - NÚMÉRO DE MÓDELO 944.101081
MOTEUR "KÖHLER" - NO. DE MÓDELO KT745, NO. DE TYPE 3016

NO. DE DÉ
 RÉF. DE PIÈCE
 DESCRIPTION - QTY

LE LOGEMENT DE SOUFFLERIE Y CONFOND 6-32-23

1	25 086 399-S VIS - 6	1
2	25 086 450-S VIS - 3	2
3	25 086 397-S VIS - 8	3
4	32 146 15-S PLAQUE D'APPUI-1	4
5	32 063 19-S DÉFLECTEUR #1 - 1	5
6	32 063 20-S DÉFLECTEUR #2 - 1	6
7	25 086 400-S VIS - 2	7
8	25 086 406-S VIS - 2	8
9	32 063 17-S DÉFLECTEUR CG - 1	9
10	32 063 18-S DÉFLECTEUR CD - 1	10
12	32 445 01-S ATTACHE DE RETENUE - 2	12
13	32 027 16-S CARTER DE VENTILATEUR - 1	13

GRUPE D'ADMISSION D'AIR 10-32-13

1	25 173 09-S BOUCHON - 1	1
3	32 083 09-S FICHIER D'AIR- 1	3
6	32 041 04-S JOINT - 1	6
7	32 096 20-S COUVERCLE DU FILTRE À AIR - 1	7
9	25 153 15-S JOINT TORIQUE - 2	9
12	32 094 13-S FILTRE À AIR DE BASE - 1	12

REMARQUE: Toutes les dimensions de composant sont données en pouces E.-U. --1 pouce = 25,4 mm

TRACTEUR - - NÚMERO DE MODELO 944.101081
MOTOR "KOHLER" - NO. DE MODELO KT745, NO. DE TIPO 3016

LES ILLUSTRATIONS SONT ET NE SONT PAS POUR BUT DE MONTRER TOUS LES DÉTAILS POUR CHAQUE COMPOSANT

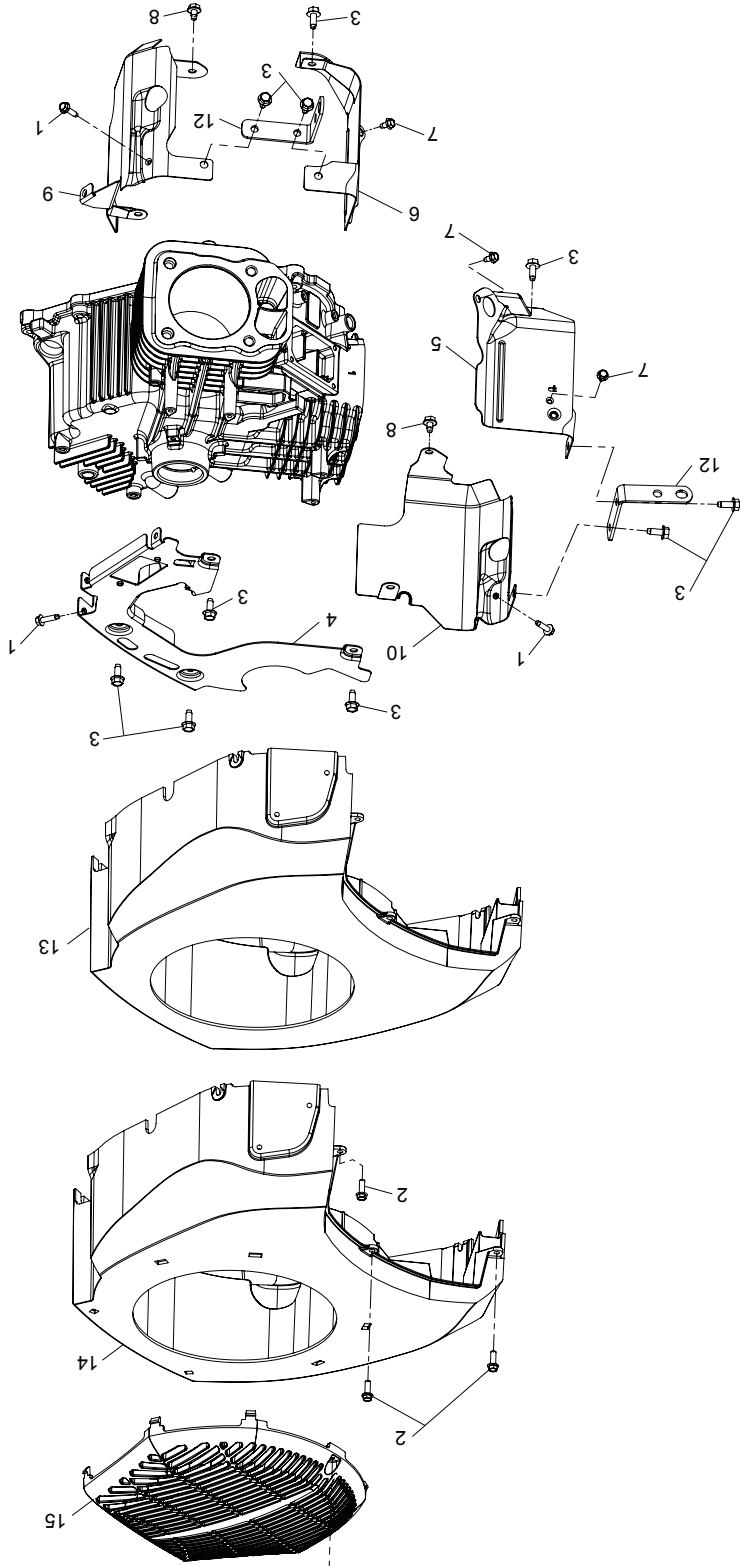

LE LOGEMENT DE SOUFFLERIE Y CONFOND
 KT715, 725, 730, 735, 740, 745

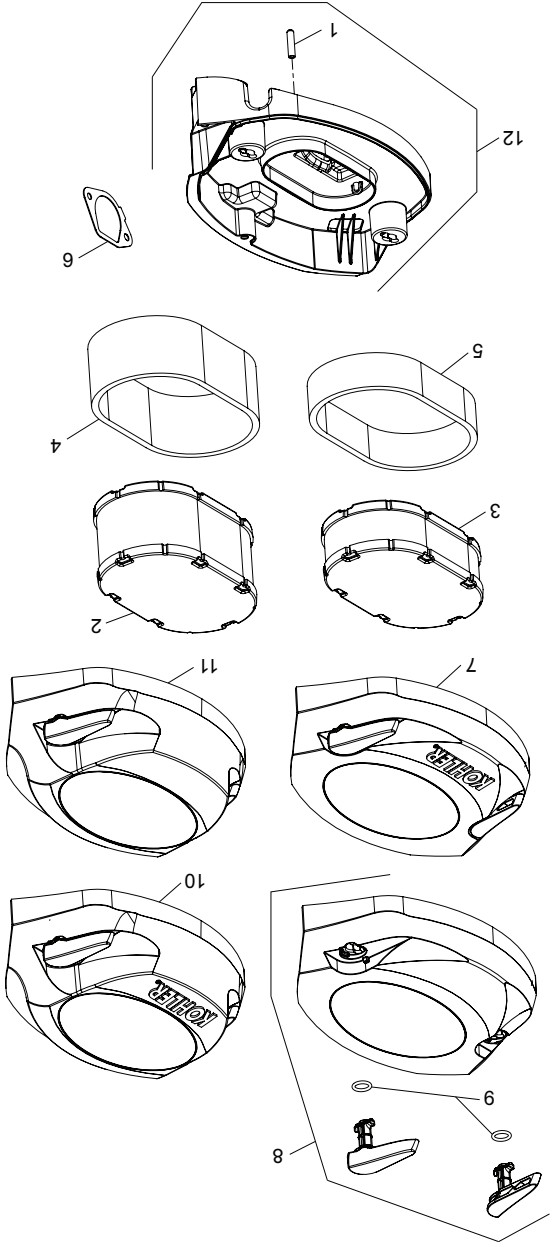

GRUPE D'ADMISSION D'AIR
 KT 715, 725, 730, 735, 740, 745

LES ILLUSTRATIONS SONT ET NE SONT PAS POUR BUT DE MONTRER TOUS LES DÉTAILS POUR CHAQUE COMPOSANT

TRACTEUR - - NÚMÉRO DE MODÉLE 944.101081
MOTEUR "KÖHLER" - NO. DE MODÉLE KT745, NO. DE TYPE 3016

NO. DE RÉF. PIÉCE DESCRIPTION - QTY

GROUPE D'ALLUMAGE 5-32-122

1	25 132 12-S	BOUGIE D'ALLUMAGE - 2	1
2	25 086 402-S	VIS - 2	2
3	237878-S	KIT DE STATOR 15/20 AMP - 1	3
4	25 086 361-S	VIS - 1	4
5	25 340 04-S	CLE - 1	5
6	25 468 09-S	RONDELLE PLAT - 1	6
7	20 146 05-S	PLAQUE DE MONTAGE DU VENTILATEUR - 1	7
8	32 018 03-S	VOLANT DE RETENUE DU VENTILATEUR - 2	8
9	32 157 04-S	VENTILATEUR - 1	9
10	32 162 03-S	L'HERBE ÉCRAN - 1	10
11	25 086 399-S	VIS - 4	11
12	25 155 41-S	CONNECTEUR - 1	12
13	25 454 03-S	ATTACHE DE CÂBLE - 1	13
14	32 025 25-S	ASSEMBLAGE DU VOLANT MOTEUR - 1	14
15	32 584 06-S	MODULE D'ALLUMAGE - 2	15
16	32 176 33-S	ENSEMBLE DE FAISCEAU DE FILS - 1	16
18	41 403 10-S	REDRESSEUR - 1	18
19	32 518 02-S	FAISCEAU DE FILS - 1	19

REMARQUE: Toutes les dimensions de composant sont données en pouces E.-U. --1 pouce = 25,4 mm

TRACTEUR - - NÚMERO DE MODELO 944.101081
MOTEUR "KÖHLER" - NO. DE MODELO KT745, NO. DE TIPO 3016

GRUPE D'ALLUMAGE
 KT715, 725, 730, 735, 740, 745

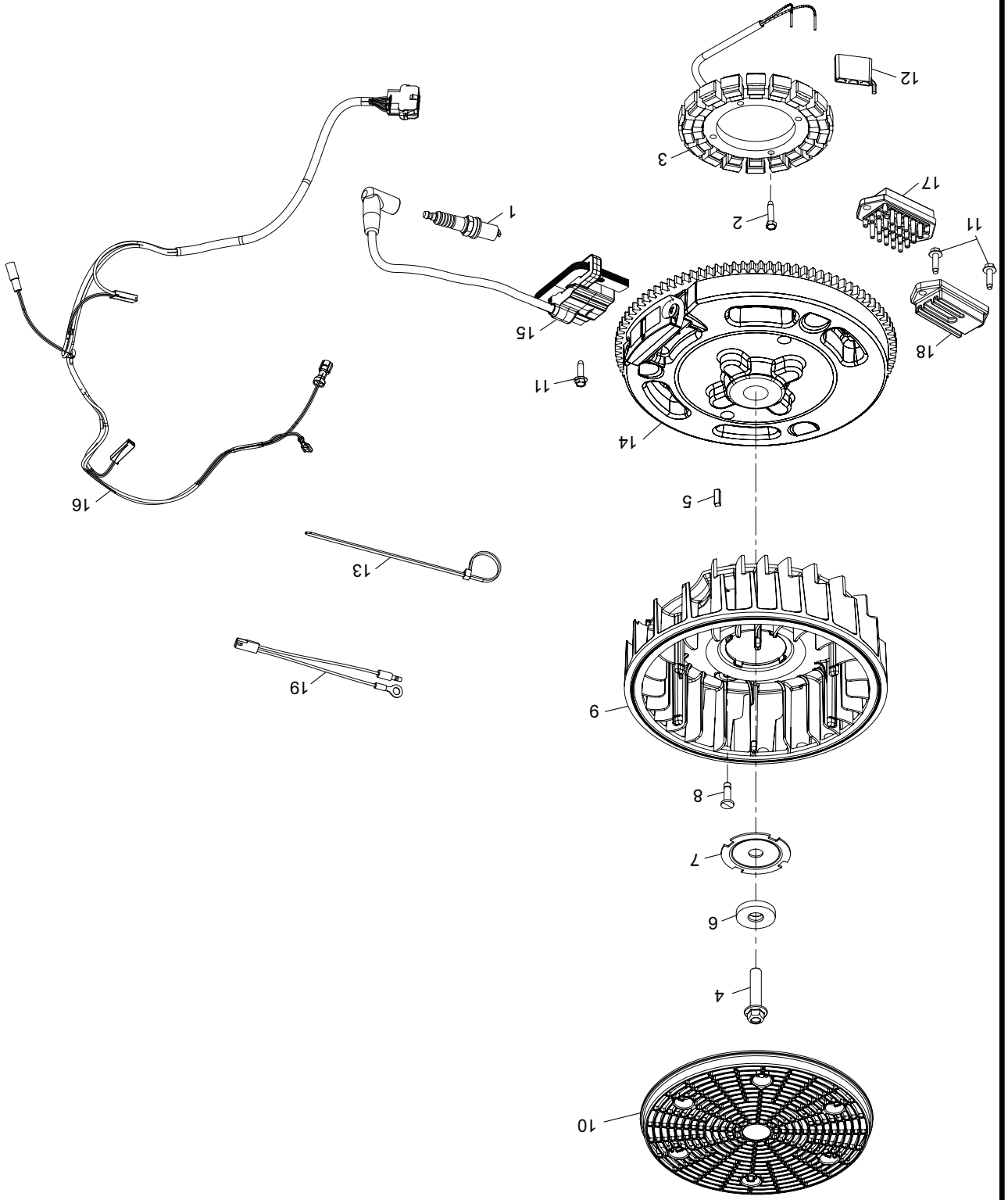

LES ILLUSTRATIONS SONT ET NE SONT PAS POUR BUT DE MONTRER TOUS LES DÉTAILS POUR CHAQUE COMPOSANT

TRACTEUR - - NOMBRE DE MODELE 944.101081
MOTEUR "KOHLER" - NO. DE MODELE KT745, NO. DE TYPE 3016

NO. DE REF. PIECE DESCRIPTION - QTY

GROUPE CULASSE 10-32-4

1	32 841 02-S	KIT DE JOINT DE CULASSE - 2
2	62 086 08-S	VIS M10X1.5X90 - 8
3	32 017 01-S	SOUAPE D'ADMISSION - 2
4	32 016 01-S	SOUAPE D'ÉCHAPPEMENT - 2
5	275067-S	ENTRETOISE (.010") - 2
6	12 755 03-S	KIT DE RÉTENUE - 8
7	25 032 14-S	JOINT D'ÉTANCHÉITÉ DE LA VALVE - 2
8	25 173 28-S	CHAPÉAU DE RESSORT DE SOUPE - 4
9	32 089 05-S	RESSORT DE SOUPE - 4
10	25 599 01-S	BRAS DE CULBUTEUR - 4
11	32 019 02-S	POUSSOIR - 4
12	32 072 04-S	FERMETURE À BASCULE - 4
13	32 100 05-S	ÉCROU - 4
14	25 086 168-S	VIS - 4
15	32 146 09-S	PLAQUE-GUIDE - 2
16	32 186 03-S	BRAS DE CULBUTEUR - 4
17	32 411 04-S	TIGE DE POUSSÉE - 4
18	25 086 374-S	VIS - 8
19	25 096 09-S	LE CACHE-CULBUTEURS - 1
20	12 402 02-S	PURGEUR - 1
21	32 050 06-S	FILTRE DU RENIFLARD - 1
22	32 468 01-S	RONDELLE - 1
23	M-547050-S	ÉCROU M5X.8 - 1
24	25 096 11-S	LE CACHE-CULBUTEURS - 1
25	32 318 21-S	TÊTE DE VÉRIN (#1) - 1
26	32 318 22-S	TÊTE DE VÉRIN (#2) - 1
27	25 326 62-S	FLEXIBLE DE RENIFLARD - 1
28	32 096 16-S	COUVERTURE - 1
29	32 072 05-S	STUD - 1
30	16 096 02-S	PURGEUR - 1
31	66 018 04-S	RÉTENUE DE REED - 1
32	25 086 400-S	VIS - 4

GROUPE D'ÉCHAPPEMENT 4-32-14

1	24 041 49-S	JOINT DU COLLECTEUR D'ÉCHAPPEMENT (KM)
2	25 454 05-S	BARRE D'ACCOUPLÉMENT (KM) (CKY)

REMARQUE: Toutes les dimensions de composant sont données en pouces E.-U. --1 pouce = 25,4 mm

TRACTEUR - - NÚMERO DE MODELO 944.101081
MOTEUR "KOHLER" - NO. DE MODELO KT745, NO. DE TIPO 3016

LES ILLUSTRATIONS SONT ET NE SONT PAS POUR BUT DE MONTRER TOUS LES DÉTAILS POUR CHAQUE COMPOSANT

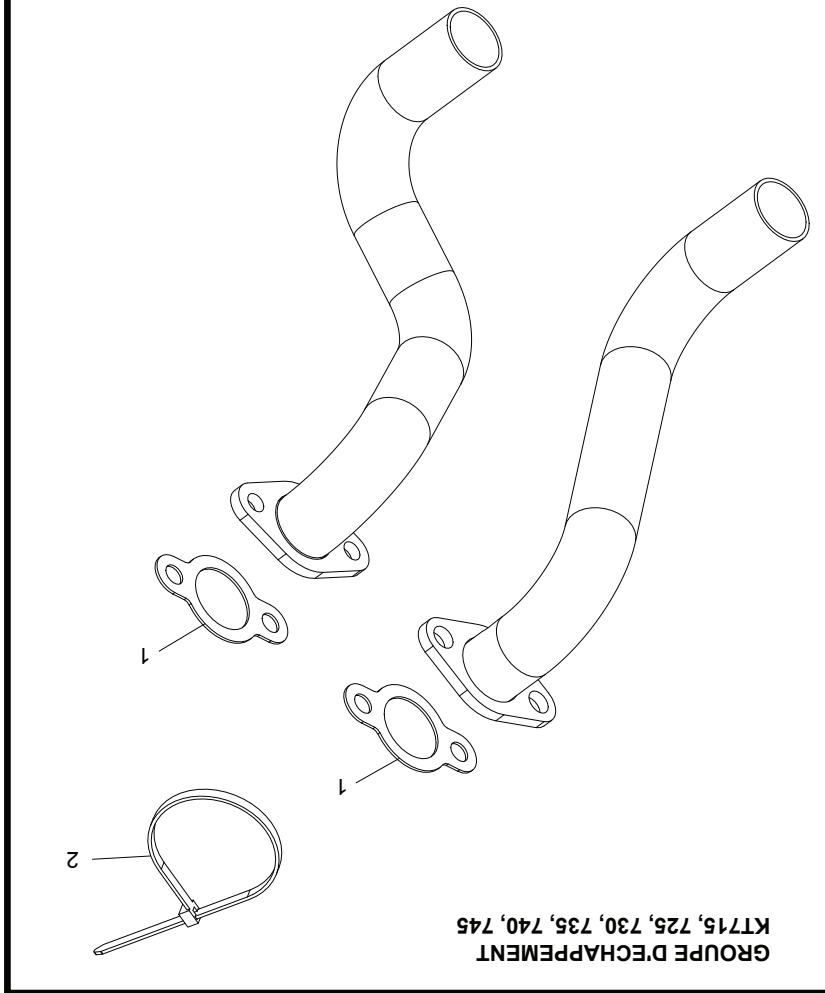
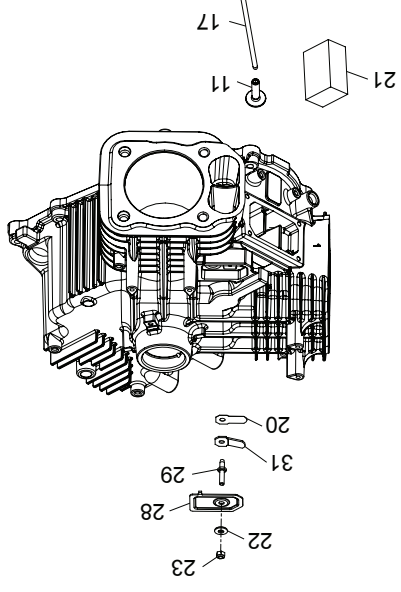
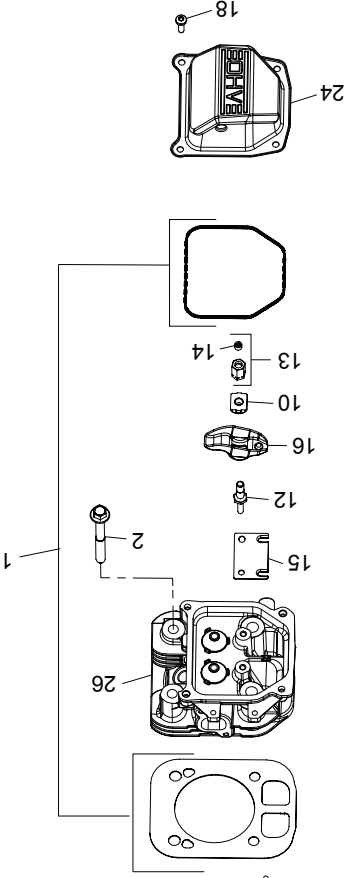

GRUPE D'ÉCHAPPEMENT
 KT715, 725, 730, 735, 740, 745

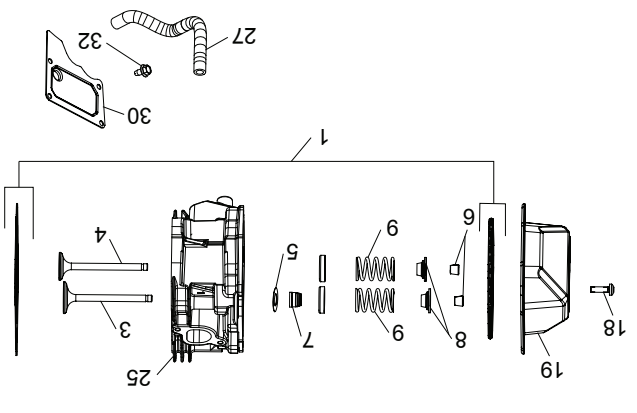

GRUPE CULASSE
 KT715, 725, 730, 735, 740, 745

TRACTEUR - - NUMÉRO DE MODÈLE 944.101081
MOTEUR "KOHLER" - NO. DE MODÈLE KT745, NO. DE TYPE 3016

NO.	DE	RÉF.	DESCRIPTION - QTY
DE	PIÈCE		
NO.			

GRUPE DE LUBRIFICATION 3-24-45

1		24 086 17-S	VIS M8X1,25X45 - 10
2		25 032 06-S	JOINT D'ÉTANCHÉITÉ D'HUILE - 1
3		25 139 57-S	BOUCHON 3/8" - 2
4		32 199 17-S	MONTAGE DU CARTER D'HUILE - 1
5		12 144 02-S	ARBRE DE PIGNON - 1
6		12 380 01-S	RÉGLEMENTER LA BROCHE - 1
7		24 448 02-S	ONGLET 1
8		32 310 02-S	KIT DE PIGNON - 1
9		24 393 51-S	POMPE À HUILE-UTILISATION 24 393 53-S - 1
10		25 086 414-S	VIS - 3
11		52 050 02-S	FILTRE À HUILE - 1
12		32 089 06-S	AXÉ DE COMPRESSION - 1
13		32 162 06-S	CRÉPINE D'HUILE - 1
14		25 139 60-S	BOUCHON 1/8" - 1

DÉMARRAGE DU GROUPE 7-32-11

1		32 098 04-S	DÉMARRÉUR ÉLECTRIQUE-(BENDIX LECTEUR) - 1
2		M-851080-S	VIS M8X1,25X80 - 2

GRUPE D'INDENTIFICATION 12-32-53

1		25 113 70-S	DÉGALCOMANIES - 1
2		25 454 05-S	BÂRRE D'ACCOUPLÉMENT - 1
3		32 113 108-S	DÉGALCOMANIES, 22HP - 1

REMARQUE: Toutes les dimensions de composant sont données en pouces E.-U. --1 pouce = 25,4 mm

TRACTEUR - - NÚMÉRO DE MODÉLE 944.101081
MOTEUR "KÖHLER" - NO. DE MODÉLE KT745, NO. DE TYPE 3016

LES ILLUSTRATIONS SONT ET NE SONT PAS POUR BUT DE MONTRER TOUS LES DÉTAILS POUR CHAQUE COMPOSANT

GRUPE D'IDENTIFICATION
 KT715, 725, 730, 735, 740, 745

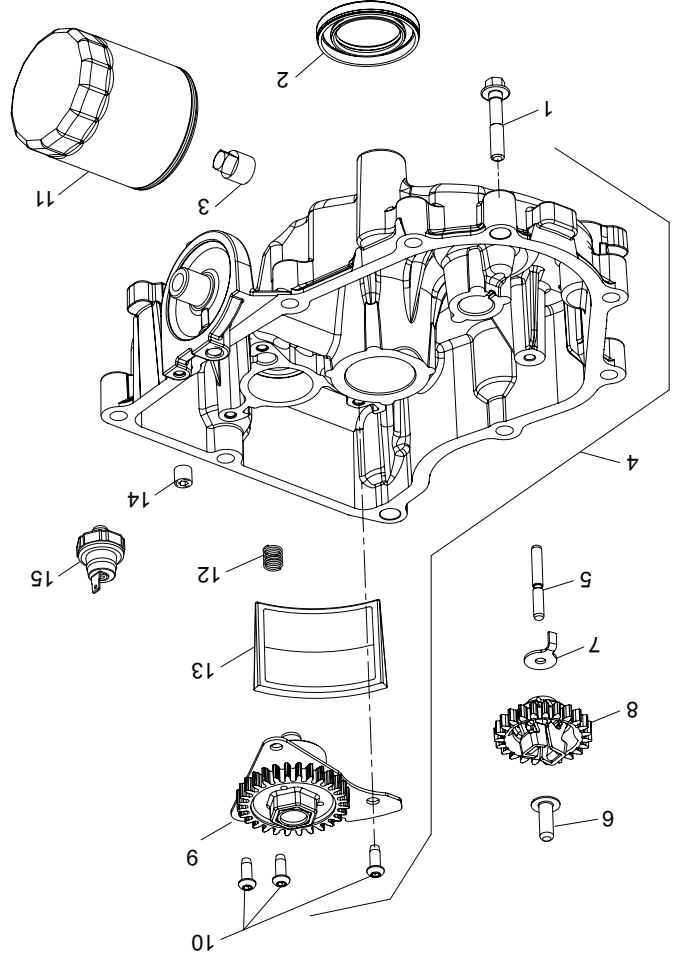
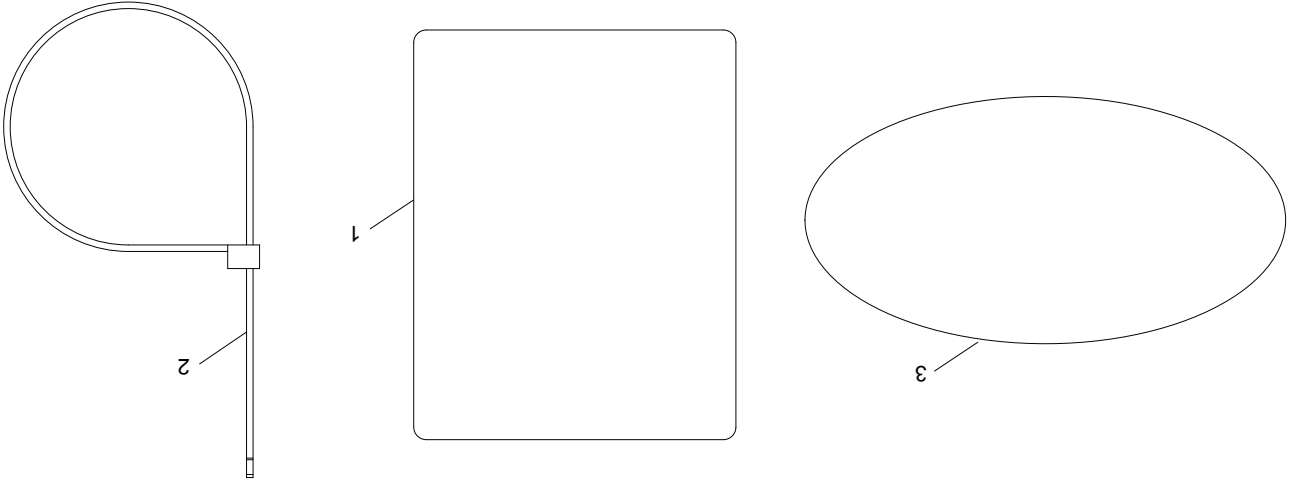

GRUPE DE LUBRIFICATION
 KT715, 725, 730, 735, 740, 745

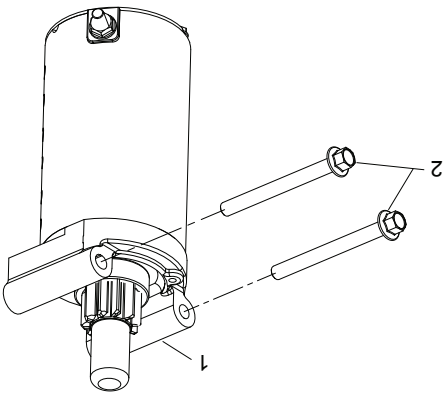

DÉMARRAGE DU GROUPE
 KT715, 725, 730, 735, 740, 745

TRACTEUR - - N° DE MODÈLE 944.101081
MOTEUR "KOHLER" - NO. DE MODELE KT745, NO. DE TYPE 3016

NO. DE RÉF. PIÈCE DESCRIPTION - QTY

GROUPE DE CARTER 2-32-15

1 24 126 243-S ATTACHE DE RETENUE - 1
 2 24 380 16-S LOCALISATION ÉPINGLE - 6
 3 24 032 19-S PHOQUE, L'HUILE (HELI-X LIP) - 1

4 24 018 01-S RETENUE, GOUVILLE - 4
 5 25 108 01-S JEU DE BAGUE (STD) - 2
 5 25 108 02-S JEU DE BAGUE (+0.08) - 2
 5 25 108 03-S JEU DE BAGUE (+0.25) - 2
 5 25 108 04-S JEU DE BAGUE (+0.50) - 2

6 25 874 13-S KIT DE PISTON, 725CC (STD) - 2
 6 25 874 15-S KIT DE PISTON, 725CC (0.08) - 2
 6 25 874 16-S KIT DE PISTON 725CC (+0.25) - 2
 6 25 874 17-S KIT DE PISTON, 725CC (+0.50) - 2

7 24 067 28-S ENSEMBLE TIGE(STD)-(#2406730S) - 2
 7 24 067 29-S ENSEMBLE TIGE (.010") (.25 MM) - 2
 8 24 018 09-S ANNEAU DE RETENUE - 1

9 24 468 15-S RONDELLE PLATÉ 11/32" - 1
 10 28 032 09-S JOINT D'ÉTANCHÉITE DE L'ARBRE - 1
 11 24 144 38-S ARBRE - 1

12 M-931010-S RONDELLE PLATE 9 MM - 1
 13 25 086 398-S VIS - 1
 14 12 153 07-S JOINT TORIQUE - 1

15 25 153 09-S JOINT TORIQUE - 1
 16 32 010 07-S ASSEMBLAGE D'ARBRE À CAMES - 1
 17 32 038 12-S LA JAUGE - 1

18 32 123 14-S TUBE DE REMPLISSAGE D'HUILE - 1

GROUPE DE VILBREQUIN 1-32-12

1 32 014 327-S MONTAGE DU VILBREQUIN(1.000" X 3.16") - 1
 2 52 139 09-S BOUCHON- 1

REMARQUE: Toutes les dimensions de composant sont données en pouces E.-U. --1 pouce = 25,4 mm

TRACTEUR - - NÚMÉRO DE MÓDELE 944.101081
MOTEUR "KÖHLER" - NO. DE MÓDELE KT745, NO. DE TYPE 3016

LES ILLUSTRATIONS SONT ET NE SONT PAS POUR BUT DE MONTRER TOUS LES DÉTAILS POUR CHAQUE COMPOSANT

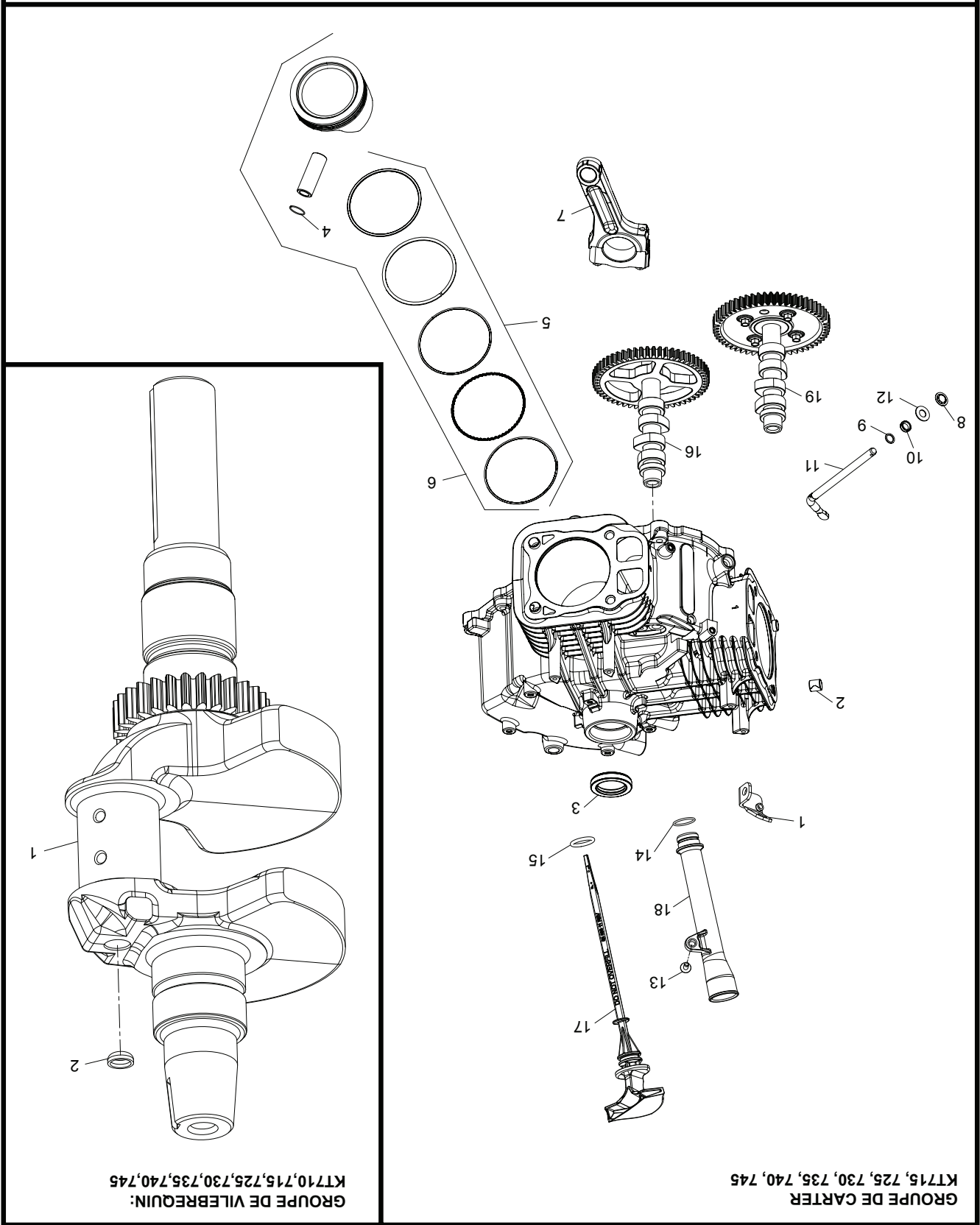

GRUPE DE VILBREQUIN:
 KT710,715,725,730,735,740,745

GRUPE DE CARTER
 KT715, 725, 730, 735, 740, 745

TRACTEUR - - NUMÉRO DE MODÈLE 944.101081 TRANSMISSION "HYDRO GEAR" - NO. DE MODÈLE G7-BCBB-1XDC-1FCA

NO. DE PIÈCE	DESCRIPTION	NO. DE PIÈCE	DESCRIPTION
64	Bloc de moteur	421196	Bloc de moteur
65	Roulement 30 X 52 X 13	173159	Roulement 30 X 52 X 13
69	Bloc de moteur	421197	Bloc de moteur
70	Rondelle, .63 X 1.0 X .05	170404	Rondelle, .63 X 1.0 X .05
71	Bague de fermeture .625 External	170405	Bague de fermeture .625 External
72	Engrenage, 14t	421198	Engrenage, 14t
73	Axe de moteur	421199	Axe de moteur
74	Rondelle, .72 X 1.16 X .04	170433	Rondelle, .72 X 1.16 X .04
80	Rondelle, .5 X 1.0 X .03	170418	Rondelle, .5 X 1.0 X .03
81	Engrenage, 45t	421200	Engrenage, 45t
82	Engrenage, 11t	421201	Engrenage, 11t
83	Goupille	170394	Goupille
90	Bague de fermeture 2.06 Interne	169539	Bague de fermeture 2.06 Interne
91	Engrenage, 60t	421202	Engrenage, 60t
92	Spaceement, 1.04 X 1.65 X .22	421203	Spaceement, 1.04 X 1.65 X .22
94	Axe 1.00 X 14.48	421204	Axe 1.00 X 14.48
95	Roulement 1.0 X 52 X 15	169535	Roulement 1.0 X 52 X 15
96	Joint d'atanchette 25 X 52 X 10 Tc 120	161157	Joint d'atanchette 25 X 52 X 10 Tc 120
120	Ventilateur 7.0 (10 Lame)	421205	Ventilateur 7.0 (10 Lame)
121	Pouille 3.86 PO	422126	Pouille 3.86 PO
122	Ecro 1/2-20	150794	Ecro 1/2-20
123	Rondelle	199658	Rondelle
130	Tube	421207	Tube
131	Ensemble à engrenage intérieur	169531	Ensemble à engrenage intérieur
132	Joint torique, -137, .103 X 2.050	421208	Joint torique, -137, .103 X 2.050
133	Couverture de pompe de charge	421209	Couverture de pompe de charge
134	Vis 1/4-20 X .75	178343	Vis 1/4-20 X .75
140	Spaceement, .320 X 1.005 X .179	421210	Spaceement, .320 X 1.005 X .179
142	Shcs 5/16-24 X 1 Patch	421211	Shcs 5/16-24 X 1 Patch
147	Ressort	421212	Ressort
152	Engrenage 14t	421213	Engrenage 14t
153	Engrenage 10t	421214	Engrenage 10t
154	Goupille, .499 X 1.20	421215	Goupille, .499 X 1.20
155	Circlip en spirale .875	421216	Circlip en spirale .875
170	Palet, Frein	142883	Palet, Frein
171	Rotor, Frein	421217	Rotor, Frein
172	Plaque, Palet	142882	Plaque, Palet
175	Boulon 1/4-20 X 1	142892	Boulon 1/4-20 X 1
176	Boulon 1/4-20 X 2	170410	Boulon 1/4-20 X 2
177	Goupille .31 X .73	170409	Goupille .31 X .73
178	Ressort	170417	Ressort
179	Tige, Frein	178330	Tige, Frein
181	Ecro 5/16-24	170415	Ecro 5/16-24
182	Goupille 3/32 X 3/4	170416	Goupille 3/32 X 3/4
183	Spaceement, .26 X .57 X .87	170411	Spaceement, .26 X .57 X .87
184	Rondelle, .27 X .88 X .12	142884	Rondelle, .27 X .88 X .12
185	Ressort	178335	Ressort
191	Tube .16 X .28 X 9.25	421218	Tube .16 X .28 X 9.25
200	Jeu, Joint d'atanchette	421219	Jeu, Joint d'atanchette
(10)	Goupille .25 X .375		Goupille .25 X .375
(26)	Joint d'atanchette 1.250 X .250		Joint d'atanchette 1.250 X .250
(30)	Joint de levre .375 X .75 X .25		Joint de levre .375 X .75 X .25
(31)	Bague de fermeture .375 External		Bague de fermeture .375 External
(33)	Bague de fermeture .750 Interne		Bague de fermeture .750 Interne
(35)	Bague de fermeture .375 External		Bague de fermeture .375 External
(41)	Joint de levre 18 X 32 X 7		Joint de levre 18 X 32 X 7
(46)	Twhcs 5/16-24 X 1.00		Twhcs 5/16-24 X 1.00
(56)	Joint de levre 17 X 40 X 7		Joint de levre 17 X 40 X 7
(57)	Bague de fermeture 1.575 Interne		Bague de fermeture 1.575 Interne
(71)	Bague de fermeture .625 External		Bague de fermeture .625 External
(90)	Bague de fermeture 2.06 Interne		Bague de fermeture 2.06 Interne
NO. DE PIÈCE	DESCRIPTION	NO. DE PIÈCE	DESCRIPTION
(96)	Joint d'atanchette 25 X 52 X 10 Tc	201	Joint torique, -137, .103 X 2.050
(130)	Tube	(155)	Circlip en spirale .875
(132)	Joint torique, -137, .103 X 2.050	201	Section centrale, C.D., Chrg
(137)	Ressort .125 X .875	20	Section centrale, C.D., Chrg
(136)	Ressort .42 X .75	(22)	Plat de déviation
(135)	Roulement 7/16"	24	Contrôle de prise
(134)	Vis 1/4-20 X .75	25	Contrôle de prise
(207)	Jeu, Ventilateur/Pouille	(26)	Joint d'atanchette 1.250 X .250
(134)	Vis 1/4-20 X .75	(27)	Hffcs 3/8-16 X 1.5
(133)	Couverture de pompe de charge	(135)	Roulement 7/16"
(132)	Joint torique .137, .103 X 2.050	(136)	Ressort .42 X .75
(131)	Ensemble à engrenage intérieur	(137)	Ressort .125 X .875
(137)	Jeu, Charge	421222	Jeu, Charge
(137)	Ressort .125 X .875		
(136)	Ressort .42 X .75		
(135)	Roulement 7/16"		
(134)	Vis 1/4-20 X .75		
(133)	Couverture de pompe de charge		
(132)	Joint torique .137, .103 X 2.050		
(131)	Ensemble à engrenage intérieur		
(120)	Ventilateur 7.0 (10 Lame)		
(121)	Pouille 3.86 PO		
(122)	Ecro 1/2-20		
(123)	Rondelle		
210	Jeu, Axe d'entrée	421224	Jeu, Axe d'entrée
214	Jeu, G700 Ros	421225	Jeu, G700 Ros
141	Assemblée neutre		
156	Arrêt, commutateur		
157	Rivet, 5/32		
158	Interrupteur, Rcs	421226	Interrupteur, Rcs
215	Jeu, G700 Rtn/Ros	421226	Jeu, G700 Rtn/Ros
44	Bras, commande		
(46)	Vis 5/16-18 X 1		
145	Assemblée, Rtn		
146	Rondelle, .343 X 1.500 X .062		
157	Rivet, 5/32		
159	Attache		
216	Jeu, Reniflard	421227	Jeu, Reniflard
217	Raccord, 9/16 Sae	421228	Raccord, 9/16 Sae
217	Bouchon		
217	Jeu, Dérivation		
34	Bras de déviation		
(35)	Bague de fermeture	421229	Bague de fermeture
218	Jeu, Filtre Protecteur	421229	Jeu, Filtre Protecteur
105	Hffcs 1/4-20 X .75		
106	Protecteur, Filtre, C.D.		
219	Jeu, Amortisseur	422129	Jeu, Amortisseur
115	Amortisseur		
116	Support		
117	Goujon fileté		
118	Rondelle, 5/16 Lock		
119	Ecro 5/16-18		

(*) Indique que pièce est repris ailleurs et est disponible en tant que partie individuelle.

REMARQUE: Toutes les dimensions de composant sont données en pouces E.-U. -- 1 pouce = 25,4 mm

**TRACTEUR - - NUMÉRO DE MODÈLE 944.101081
TRANSMISSION "HYDRO GEAR" - NO. DE MODÈLE G7-BCBB-1XDC-1FCA**

G7-BCBB-1XDC-1FCA

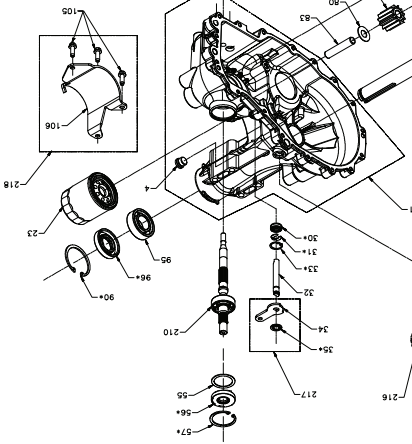
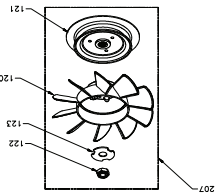
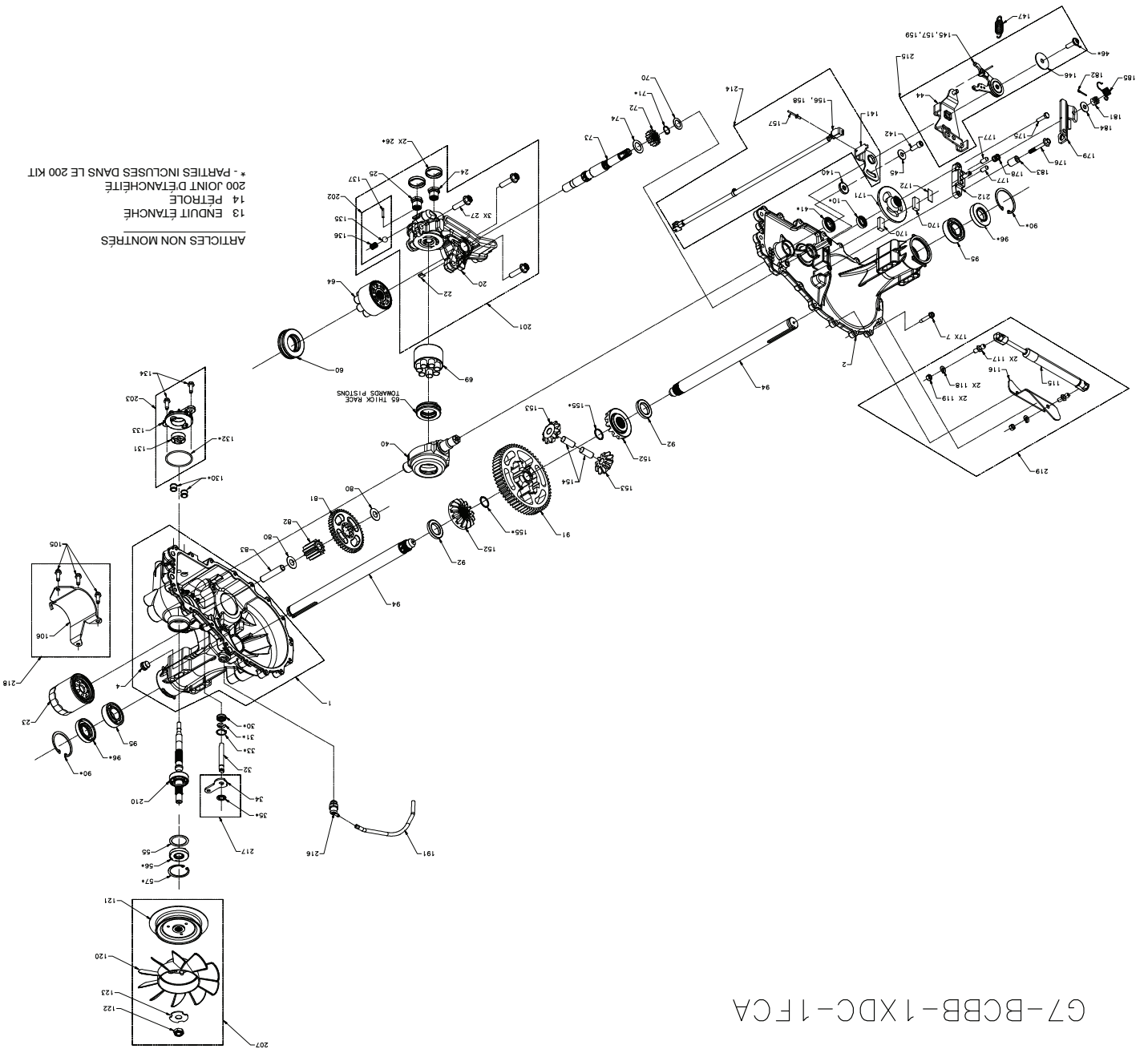

ARTICLES NON MONTRES
13 ENDUIT ÉTANCHÈ
14 PETROLE
200 JOINT D'ÉTANCHÉITE
* - PARTIES INCLUSES DANS LE 200 KIT

NO. DE PIÈCE

1 421183 Jeu, Principal d'entraînement

4 170434 Bouchon 9/16-18
Jeu, Principal d'entraînement
2 421184 Douille, 25 X .375
Couple, 25 X .375
Bouchon 9/16-18
Principal d'entraînement

DESCRIPTION

NO. DE PIÈCE

23 421186 Filtre, Huile
26 421187 Joint d'atanchette 1,250 X .250
27 421188 Hfhcs 3/8-16 X 1,5 (Patch)
30 421189 Joint d'atanchette .375 X .75 X .25
31 421190 Bague de fermeture .375 External
32 Tige
33 Bague de fermeture .750 Interne
35 Bague de fermeture

DESCRIPTION

40 170354 Trunion, Swashplate
41 170363 Joint de levre 18 X 32 X 7
45 142884 Rondelle, .24 X .88 X .06
46 421194 Twhcs 5/16-24 X 1.00
55 170360 Rondelle, 1.23 X 1.56 X .04
56 170361 Joint d'atanchette 17 X 40 X 7
57 169870 Bague de fermeture 1.575 Interne
60 421195 Roulement
22 421185 Plat de déviation
14 Huile, 20W50
13 Tube, Mastic
10 417764 Joint de levre .625 X 1.0
7 170356 Hfhcs 1/4-20 X 1.25
4 170434 Bouchon 9/16-18
Bearing, Flange 1.0 X 1.376 X .99
Douille, .865 X .985 .790
Jeu, Douille, .624 X .729 X .562
Douille, 1.0 X 1.376 X .99
Douille, .865 X .985 X .790
Douille, 624 X .719 X .562
Couple, 25 X .375
Principal d'entraînement
Bouchon 9/16-18
Jeu, Principal d'entraînement

TRACTEUR -- NUMÉRO DE MODÈLE 944.101081

DECALCOMANIES

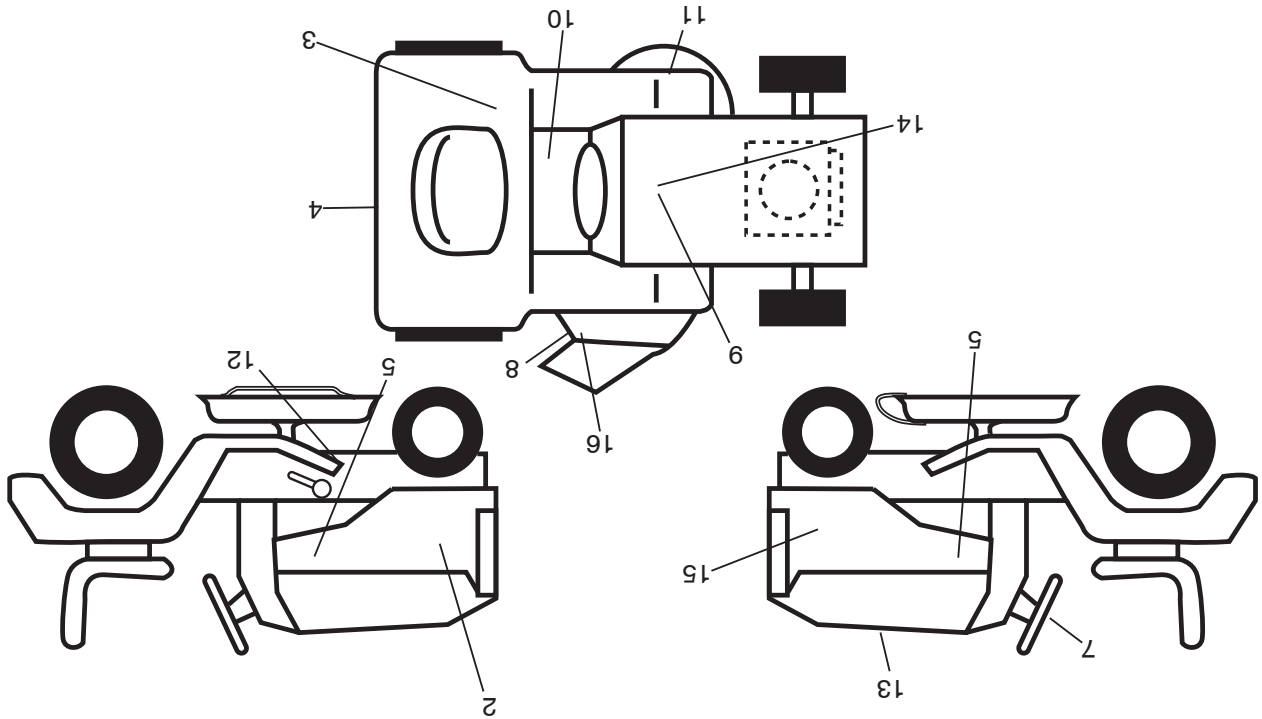

DESCRIPTION

NO. DE PIÈCE	DESCRIPTION	NO. DE PIÈCE	DESCRIPTION
13	582458201	13	Decalcomanie
14	448709	14	Decalcomanie de la batterie
15	586208401	15	Decalcomanie de l'aille C.D.
16	584904601	16	Decalcomanie avertissement
--	581724801	--	Decalcomanie dérivation
--	193279X428	--	Coussin d' repose-pied C.G.
--	193101X428	--	Coussin d' repose-pied C.D.
--	115817824	--	Manuel de L'Opérateur
--	582245201	--	Manuel des Pièces de Rechange (Anglais/Français)

DESCRIPTION

NO. DE PIÈCE	DESCRIPTION	NO. DE PIÈCE	DESCRIPTION
2	586208402	2	Decalcomanie de l'aille C.G.
3	586724301	3	Decalcomanie, Avertissement de réserve
4	587390301	4	Valton de carburant
5	586456301	5	Decalcomanie de l'aille
7	587389701	7	Decalcomanie du capot
8	581580002	8	Decalcomanie, Schéma de tondeuse
9	149517	9	Decalcomanie de danger/poison de la batterie
10	581579001	10	Decalcomanie de l'aille
11	581724501	11	Decalcomanie, d' avertissement de tondeuse
12	421534	12	Decalcomanie de courroie trapézoïdale de la tondeuse

ROUES & PNEUS

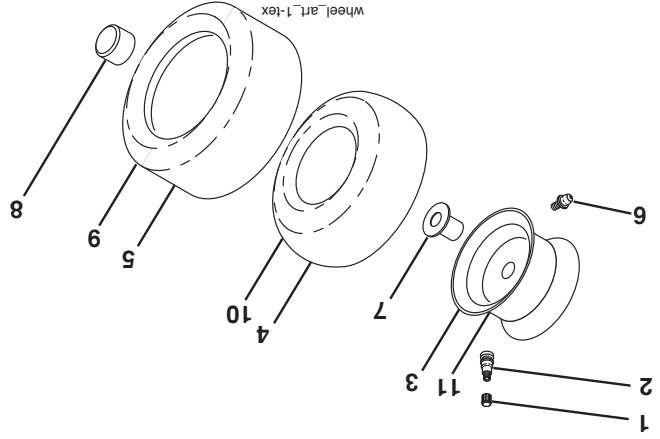

DESCRIPTION

NO. DE PIÈCE	DESCRIPTION	NO. DE PIÈCE	DESCRIPTION
1	59192	1	Capuchon de la valve du pneu
2	65139	2	Tubulure de la valve
3	106228X613	3	Ensemble de la jante antérieure
4	8134H	4	Chambre à air antérieure (non fournie)
5	106230X	5	Pneu antérieur 16 x 6.5-8
6	278H	6	Graisseur (roue antérieure seulement)
7	9040H	7	Paller à bride (roue antérieure seulement)
8	104757X428	8	Chapeau de l'essieu
9	105588X	9	Pneu arrière 23 x 10.5-12
10	7154J	10	Chambre à air arrière (non fournie)
11	106277X613	11	Ensemble de la jante arrière
--	144334	--	Joint d'étanchéité de pneu (tube de .30L [10 oz. Tube])

REMARQUE: Toutes les dimensions de composant sont données en pouces E.-U. --1 pouce = 25,4 mm

TRACTEUR - - NUMÉRO DE MODÈLE 944.101081
ENSEMBLE DU SIÈGE

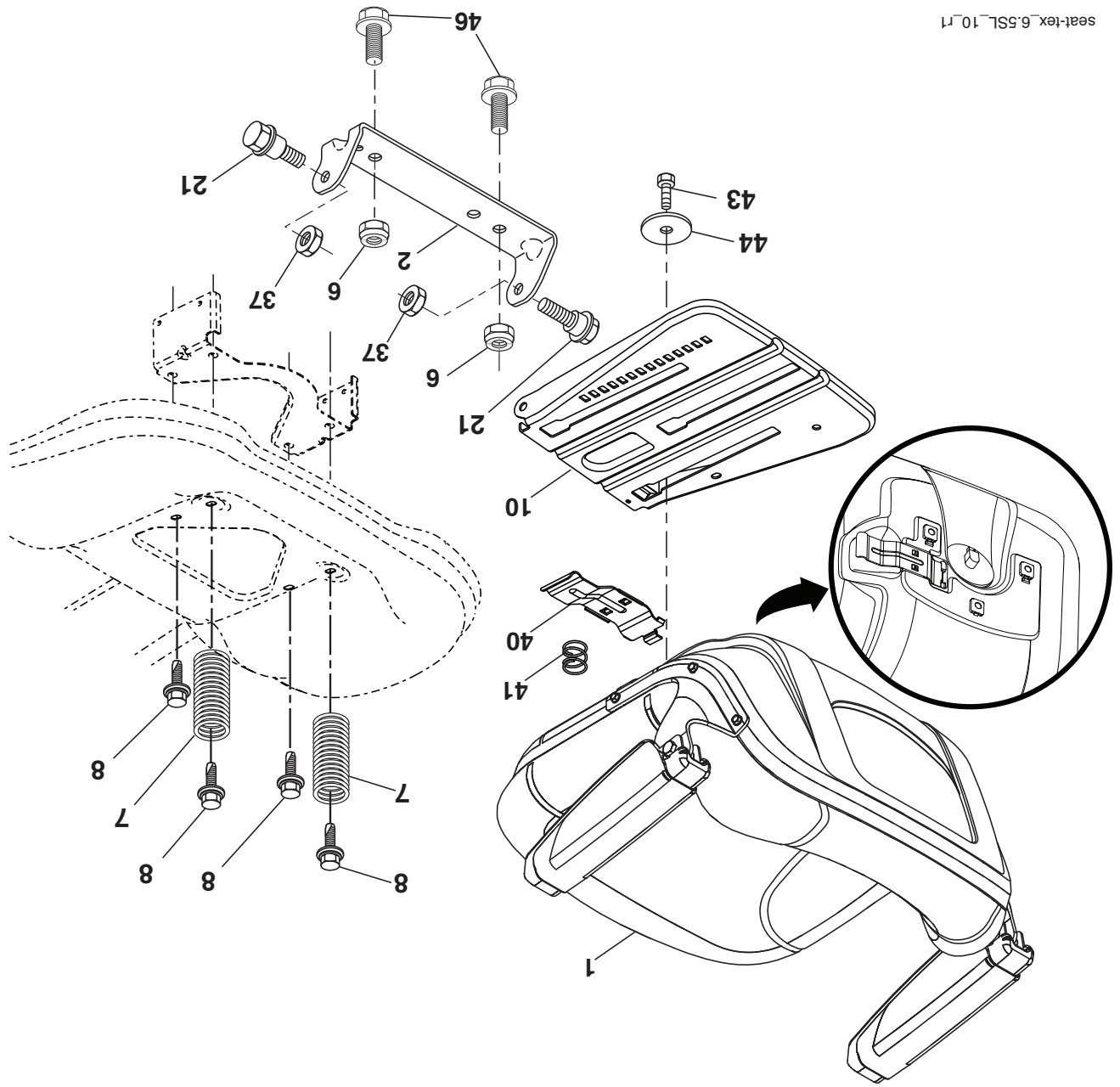

seat-tex_6.5SL_10_r1

NO.	DE	PIÈCE	DESCRIPTION
1		58650702	Siège
2		180166	Support de pivot
6		73800600	Ecroû trein H avec insert 3/8-16 unc
7		587613301	Ressort de compression du siège
8		171877	Boulon 5/16-18 unc x 3/4
10		196977	Cuvette du siège
21		587907801	Boulon à épaulement 5/16-18 X 5/8
37		73800500	Ecroû trein 5/16-18 unc

NO.	DE	PIÈCE	DESCRIPTION
40		197661	Guidon
41		198200	Ressort de compression
43		74760612	Boulon 3/8-16 x 3/4
44		19133812	Rondelle 13/32 x 2-3/8 x 12 Ja.
46		588090401	Boulon 3/8-16 x 1.125 OD

REMARQUE: Toutes les dimensions de composant sont données en pouces E.-U. --1 pouce = 25,4 mm

TRACTEUR - - NUMÉRO DE MODÈLE 944.101081
LEVAGE DE LA TONDEUSE

NO.	DÉ	RÉF.	PIECE	DESCRIPTION
2		422027		Ensemble de l'arbre
3		419497		Ensemble de l'arbre de levage C.D.
7		445060X421		Poignée cannelée du levier
10		196314		Ressort de Torsion
87		194209		Goupille fendue 7/16
88		19191912		Ressort de retenue
89		19191912		Rondelle
90		194208		Goupille fendue 5/16
91		403407		Raccord de levage
97		17000612		Vis 3/8-16 x 3/4
98		195264		Raccord de levage
116		19151516		Rondelle 15/32 x 15/16 x16 Ja.

REMARQUE: Toutes les dimensions de composant sont données en pouces E.-U. --1 pouce = 25,4 mm.

TRACTEUR -- NUMÉRO DE MODÈLE 944.101081
LEVAGE DE LA TONDEUSE

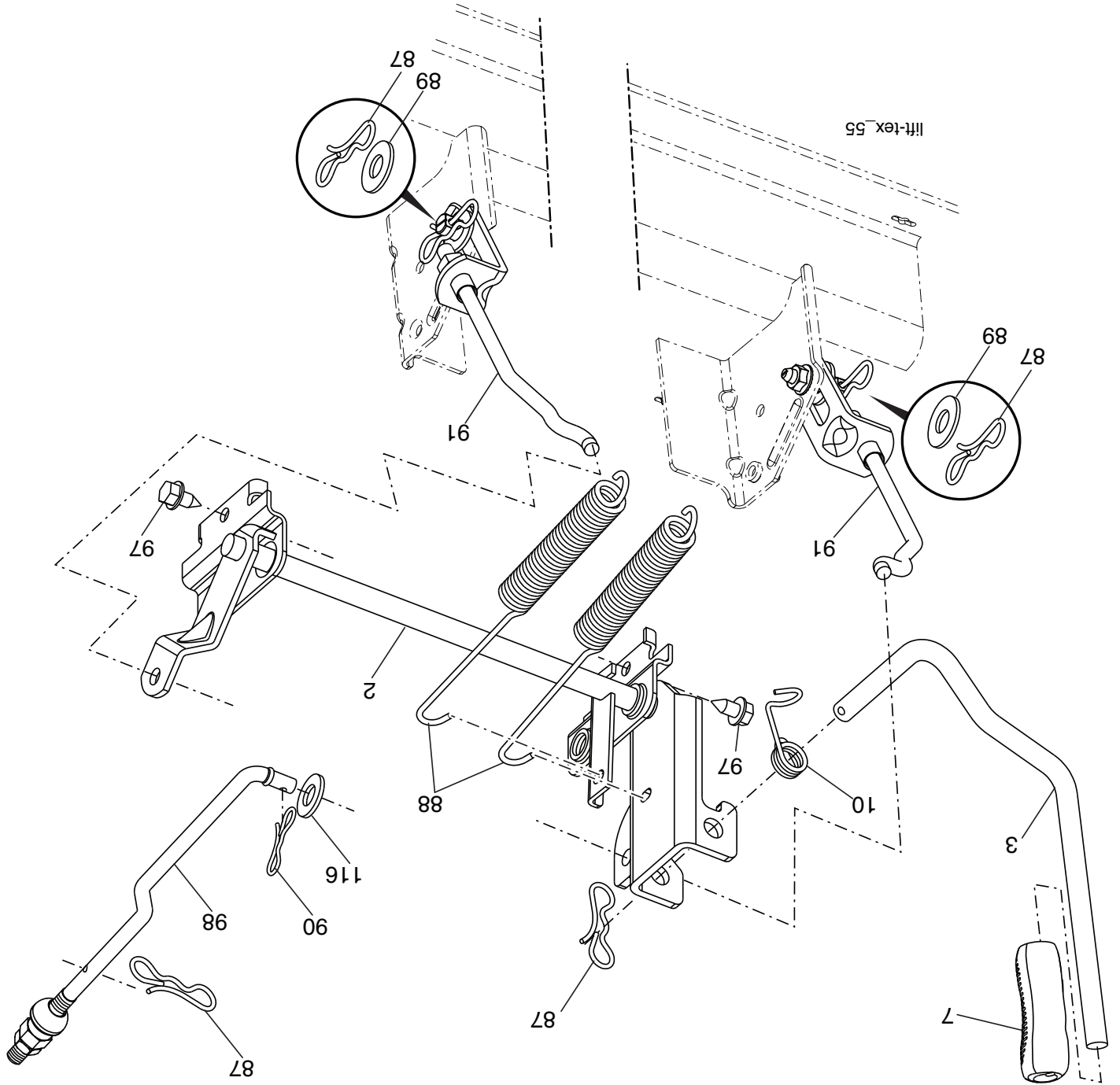

TRACTEUR - - NUMÉRO DE MODÈLE 944.101081
CARTER DE TONDEUSE

NO. DE DÉ	RÉF. PIÈCE	DESCRIPTION	NO. DE DÉ	RÉF. PIÈCE	DESCRIPTION
1	195632X421	Ensemble du carter	62	585322805	Plaque latérale
6	196066	Couvercle de mandrin C.G.	63	72110510	Boulon 5/16-18 x 1-1/4 Cat. 5
7	197181	Couvercle de mandrin C.D.	97	178515	Rondelle
11	187256	Lame de pour mètre en sac	98	196105	Ressort de retenue
12	400337	Barre	113	72110508	Boulon 5/16-18 x 3/4
13	587256401	Ensemble de l'arbre	114	187556	Tige
14	187281	Carter du mandrin	116	193406	Boulon
15	585323901	Roulement à billes	117	174873	Support des roues
16	19131312	Rondelle 13/32 x 13/16 x 12 Ja.	120	19132012	Rondelle 13/32 x 1-1/4 x 12 Ja.
18	72140505	Boulon 5/16-18 unc x 5/8	122	187557	Douille
19	194208	Goupille fendue 5/16 trehn	184	73900500	Écrou 5/16-18
21	73680500	Écrou 5/16-18 unc	185	73900700	Écrou 7/16-14 Cat. 5
24	105304X	Chapeau de manchon	187	195161	Attache à filetage
25	178102	Ressort de torsion	189	195185	Bras de suspension arrière
26	110452X	Écrou	190	196539	Boulon
27	187257X428	Défecteur de décharge	192	198468	Guide-courroie du galet-tendeur
29	131491	Tige de charnière	194	74490736	Boulon 3/8-16 x 2-1/4
32	153535	Pouille de mandrin	196	72140620	Boulon 3/8-16 unc x 2-1/2 Cat. 5
33	400234	Écrou	241	152927	Vis
34	73680600	Écrou	242	415598	Raccord de lavage
35	584309301	Vis	245	19111116	Rondelle 11/32 x 11/16 x 16 Ja.
39	197380	Pouille du galet	--	587125401	Ensemble de mandrin (compris les nos. de réf. 13-15 et 33)
41	584953901	Boulon	--	416405	Raccord à démontage rapide
43	196065	Bras du galet-tendeur	--	587739001	Ensemble du carter de tondeuse complet
46	137729	Vis. 1/4-20 x 5/8			
47	587686701	Courroie trapézoïdale de la tondeuse			
49	73900600	Écrou 3/8-16 unc			
50	72110616	Boulon 3/8-16 x 2			
52	197379	Pouille du galet-tendeur			
58	187342	Chicane C.D.			
59	187344	Chicane C.G.			
60	187607	Chicane Centrale			
61	5853222605	Plaque frontale			

REMARQUE: Toutes les dimensions de composant sont données en pouces E.-U. -- 1 pouce = 25,4 mm.

TRACTEUR - - NUMERO DE MODELE 944.101081
CARTER DE TONDEUSE

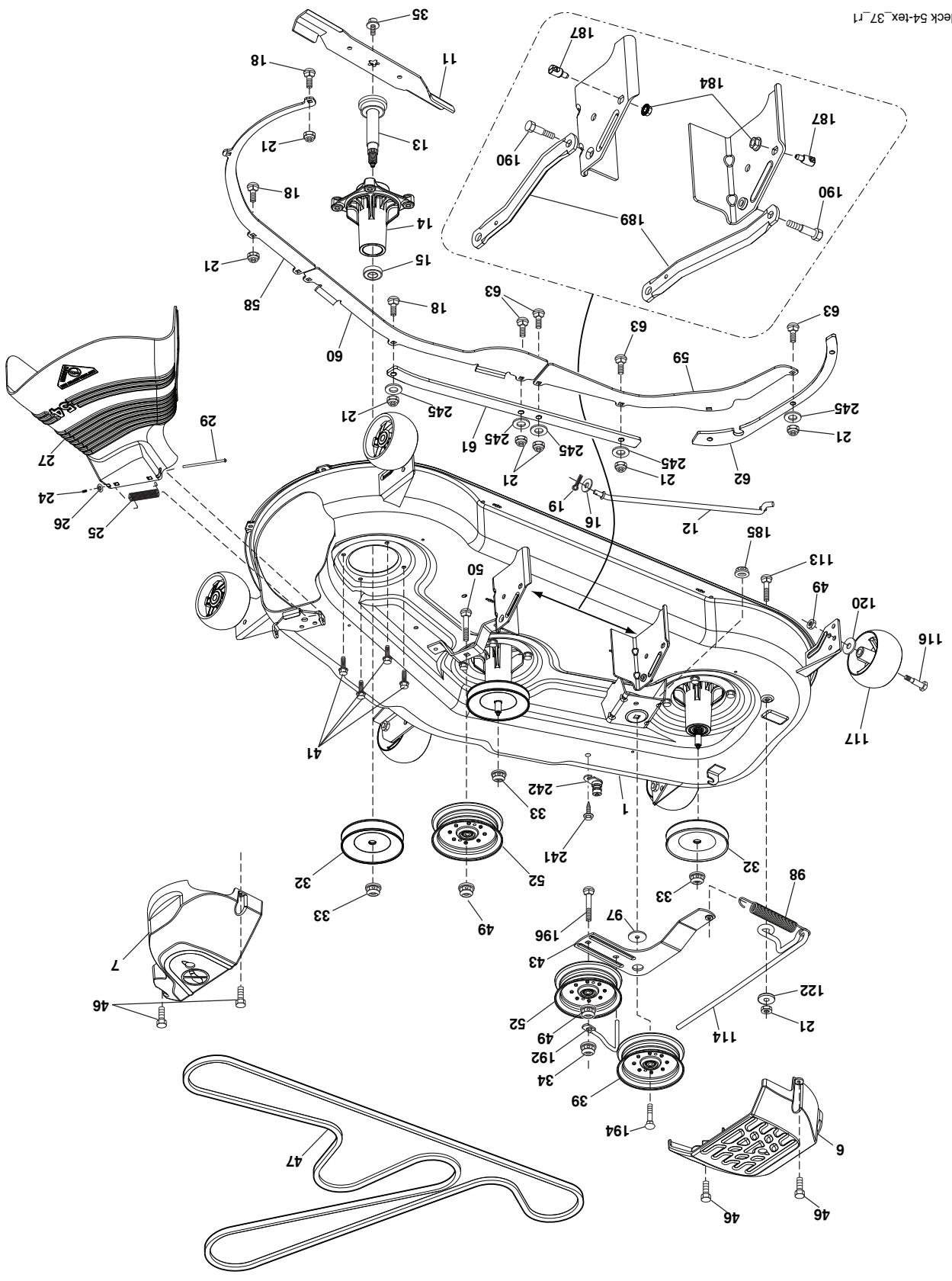

mower_deck 54-tex_37_r1

TRACTEUR - - NUMÉRO DE MODÈLE 944.101081
ENSEMBLE DE LA DIRECTION

NO.	DÉ	NO.	DESCRIPTION
REF.	PIECE		
1	414851X421		Volant de Direction
2	195968		Essieu
4	403089		Broche C.G.
5	403090		Broche C.D.
6	6266H		Rondelle 0.75 x 1.23
7	121748X		Rondelle 25/32 x 1-5/8 x 16 Ja.
8	1200029		Rondelle Clip #T5304-75
9	184946X667		Capuchon de Broche
13	121749X		Rondelle 25/32 x 1-1/4 x 16 Ja.
14	10040600		Rondelle frein 3/8
15	73540600		Ecroi Auto-Serrant 3/8-24 unF
16	587016002		Arbre de direction
19	194729		Plaque
20	196676X428		Couvercle de Direction
21	586840201		Adaptateur du volant de direction
22	585029802		Palier
26	414852X421		Insert
27	19211616		Rondelle
28	17000612		Vis 3/8-16 x 3/4
35	194732		Secteur Denté
45	587016401		Rondelle 3/8 ID 2-3/8 OD 12 Ja. PLTD
50	73900600		Ecroi 3/8-16 unc
53	188967		Rondelle Durcie .793 x 1.637 x .060
57	197246		Support d'Arrêt Supérieur
58	194747		Boulon CFM
59	194748		Rondelle
60	73971000		Ecroi Frein 5/8-11
61	194740		Raccord, LH
62	194741		Raccord, RH
63	17000512		Vis 5/16-18 x 3/4
64	199849		Collier de Retenue
66	71020748		Boulon 7/16-14 x 3
67	194737		Coussinet
68	73900700		Ecroi Frein 7/16-14 Cat. 5
69	199162		Rondelle 1.5 x .505 x .118
70	585338801		Support
75	580683701		Pignon
76	580683601		Vis
122	444962		Tapas

REMARQUE: Toutes les dimensions de composant sont données en pouce d'E.-U. - - 1 pouce = 25,4 mm.

TRACTEUR - - NUMÉRO DE MODÈLE 944.101081
ENSEMBLE DE LA DIRECTION

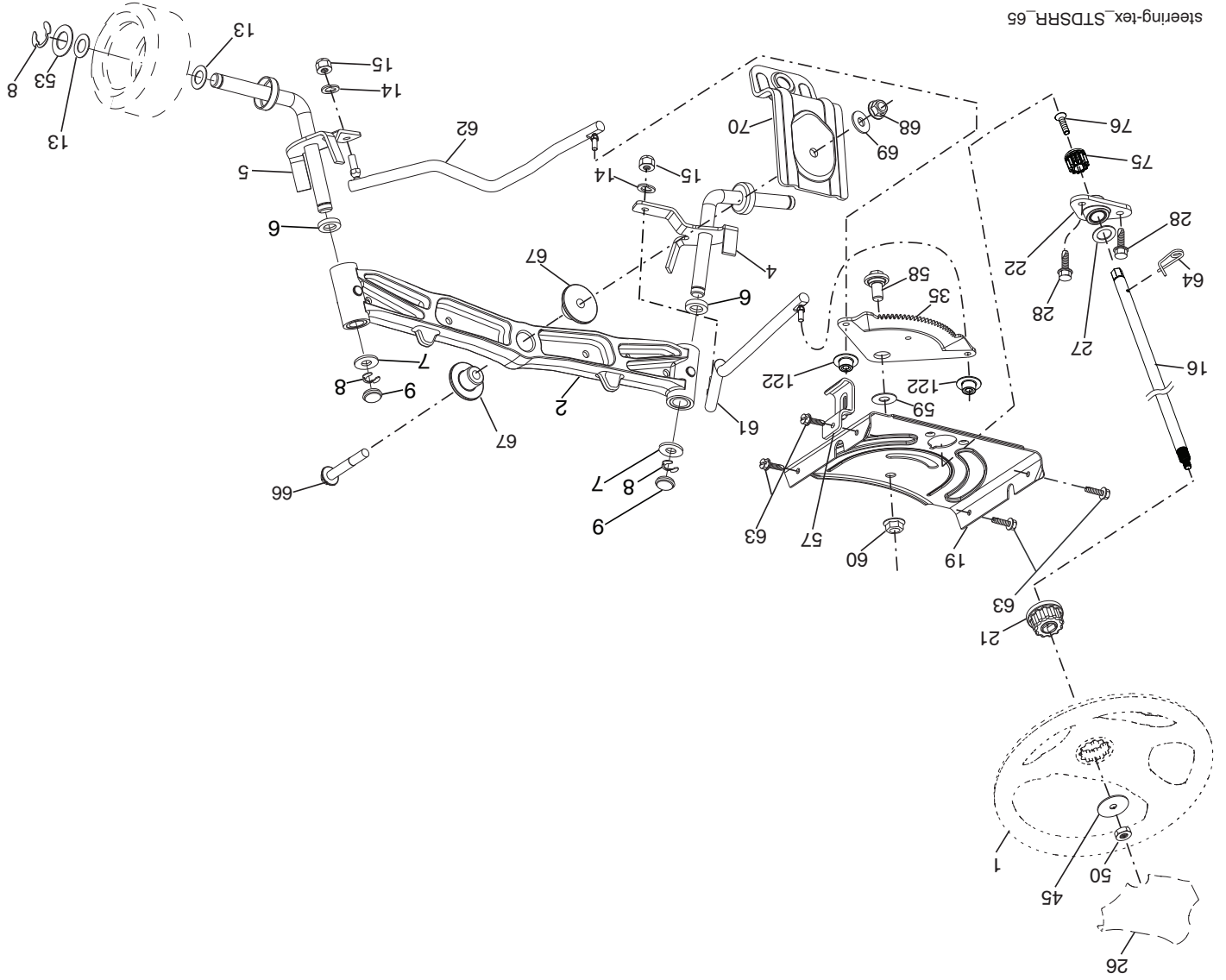

steering-tex_STDSRR_65

TRACTEUR - - NUMÉRO DE MODÈLE 944.101081

MOTEUR

NO. DE RÉF.	NO. DE PIÈCE	DESCRIPTION
1	---	Moteur Kohl-No. de modèle KT745-3016 (585446401) (Voir la assemblage de moteur.)
2	445962	Silencieux
9	408667	Ensemble de la guide courroie du moteur
11	587241401	Embrayage électrique
12	194343	Poulie
15	422804	Réservoir d'essence 4.0
18	584248701	Chapeau
20	587631703	Commande des gaz
21	438562	Vis
22	18767X421	Commande du starter
28	401135	Conduite d'essence
29	137180	Jeu de pare - étincelles
37	123487X	Bride de serrage de tuyau
41	126197X	Rondelle 1-1/2 OD x 15/32 ID x .250
42	10040700	Rondelle 7/16
45	73510400	Ecrou 1/4-20 unc
62	434017	Défecteur de débris
69	186054	Garniture de silencieux
70	583954501	Tube C.G.
71	583954801	Tube C.D.
79	192334	Vis 5/16-18 x 3/4
81	148456	Tube de vidange d'huile
82	428287	Bouchon
84	17120616	Vis 3/8-16 x 1
85	581636201	Boulon 7/16-20 x 3.0 x Ja. 5
87	198239	Boulon 5/16-18 unc x 1 w/Sems
90	17000616	Vis 3/8-16 x 1
91	187495	Douille
116	423109X421	Boulon 3/8-16
117	420828	Valeur de réservation de carburant

REMARQUE: Toutes les dimensions de composant sont données en pouce d'E.-U. - - 1 pouce = 25,4 mm.

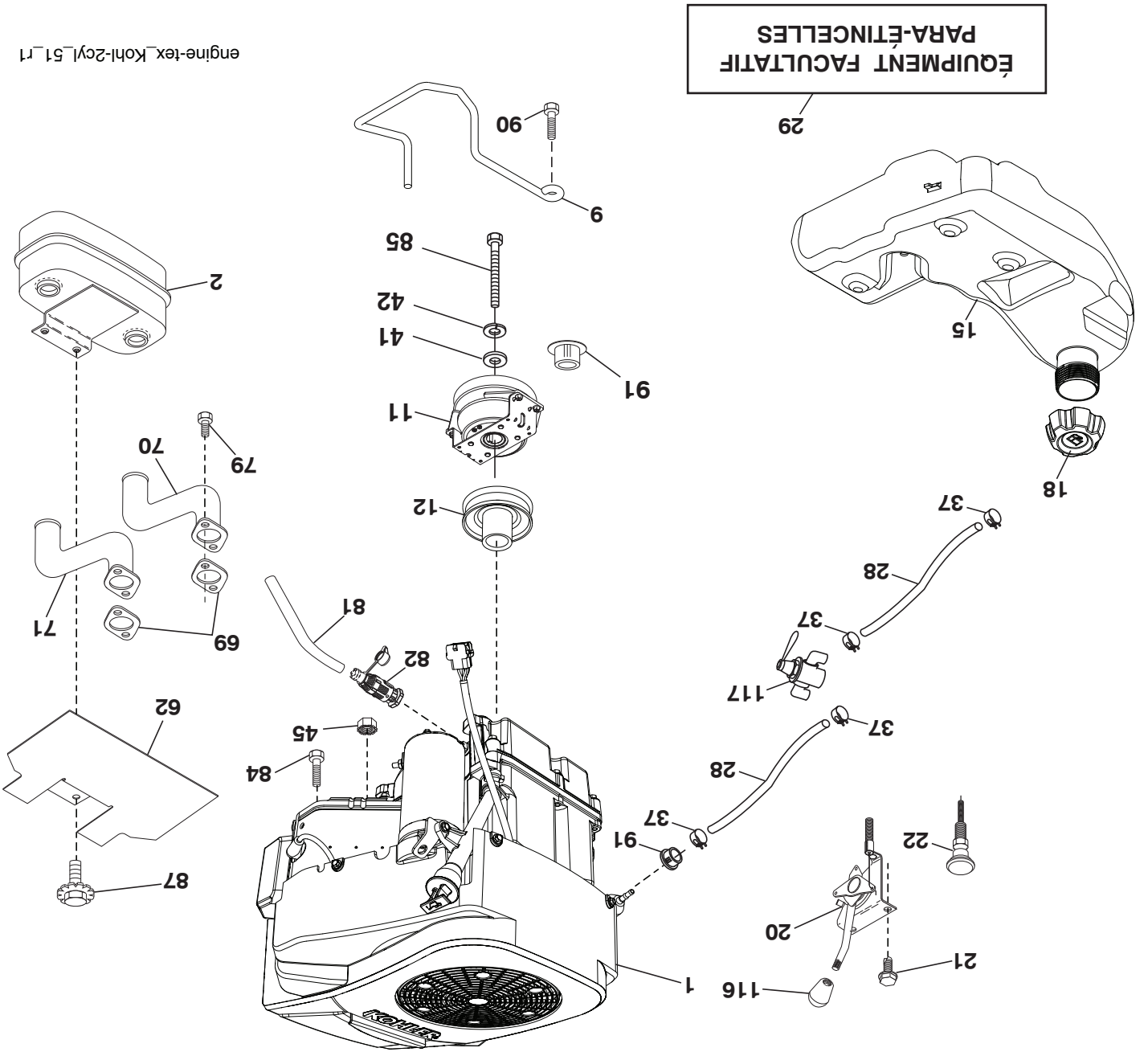

engine-tex_kohl-2cyl_51_r1

TRACTEUR - - NUMÉRO DE MODÈLE 944.101081

ENTRAÎNEMENT

NO. DE DÉ	REF.	DESCRIPTION	NO. DE DÉ	REF.	DESCRIPTION
1	---	Transmission, Hydro G7-BCBB-1XDC-	161	105709X	Ressort
2	7070E	Ciê	166	429164	Écrou .625
3	7563R	Rondelle	167	405257	Poignée de frein
7	199837	Moyeu roue arrière	184	196439X428	Poignée de frein à main
9	140080	Boulon	186	194321	Arrêtior d'entretotise
15	19131316	Rondelle 13/32 x 13/16 x 16 Ja.	187	19133210	Rondelle
17	197296	Ressort	188	582217001	Raccord d'embrayage longue
26	199679	Ressort	189	407504	Commande au sol de balancier
29	418186	Tige du frein	190	407505	Garde
33	12000053	Bague en E	196	17000616	Vis 3/8-16 x 1
35	583864501	Tige du frein de stationnement	197	585658601	Support
42	8883R	Couverture de la pédale	203	19111116	Rondelle
48	72110612	Boulon	205	123800X	Rondelle
49	72110614	Boulon	206	448596	Support
50	194327	Poulie du galet-tendeur	207	587031401	Commandez le verrou de croisière
51	73900600	Écrou 3/8-16	208	197869	Vitesse de croisière de commande de
52	194326	Galet-tendeur	209	199592	secteur
56	140294	Lourroie trapézoidale	210	197860	Culbuteur Assembly de commande de
64	197865	Axe	211	120183X	pédale
73	74490548	Boulon	213	196441X428	Roulement en nylon
74	142432	Vis 1/4 x 1/2	214	421263	Commandez le bouton de croisière
80	418184	Courroie de couple	215	197301X428	Pédale renversée
92	74760520	Boulon 5/16-18 x 1/2	221	403187	Ressort
99	418188	Ressort	222	79212010	Rondelle
114	73800500	Écrou 5/16-18 unc	224	193099X428	Boîte à outils de console
116	73900500	Écrou 5/16-18	306	76020416	Goupille fendue
121	175611	Ressort de retenue			
122	72010520	Boulon 5/16-18 x 2.50			
125	17000512	Vis 5/16-18 x 3/4			
145	163168	Rondelle			
153	4497H	Ressort			
159	76020412	Goupille fendue 1/8 x 3/4			
160	169484	Goupille fendue			

REMARQUE: Toutes les dimensions de composant sont données en pouces E.-U. --1 pouce = 25,4 mm

ENTRAÎNEMENT

TRACTEUR - - NUMÉRO DE MODÈLE 944.101081

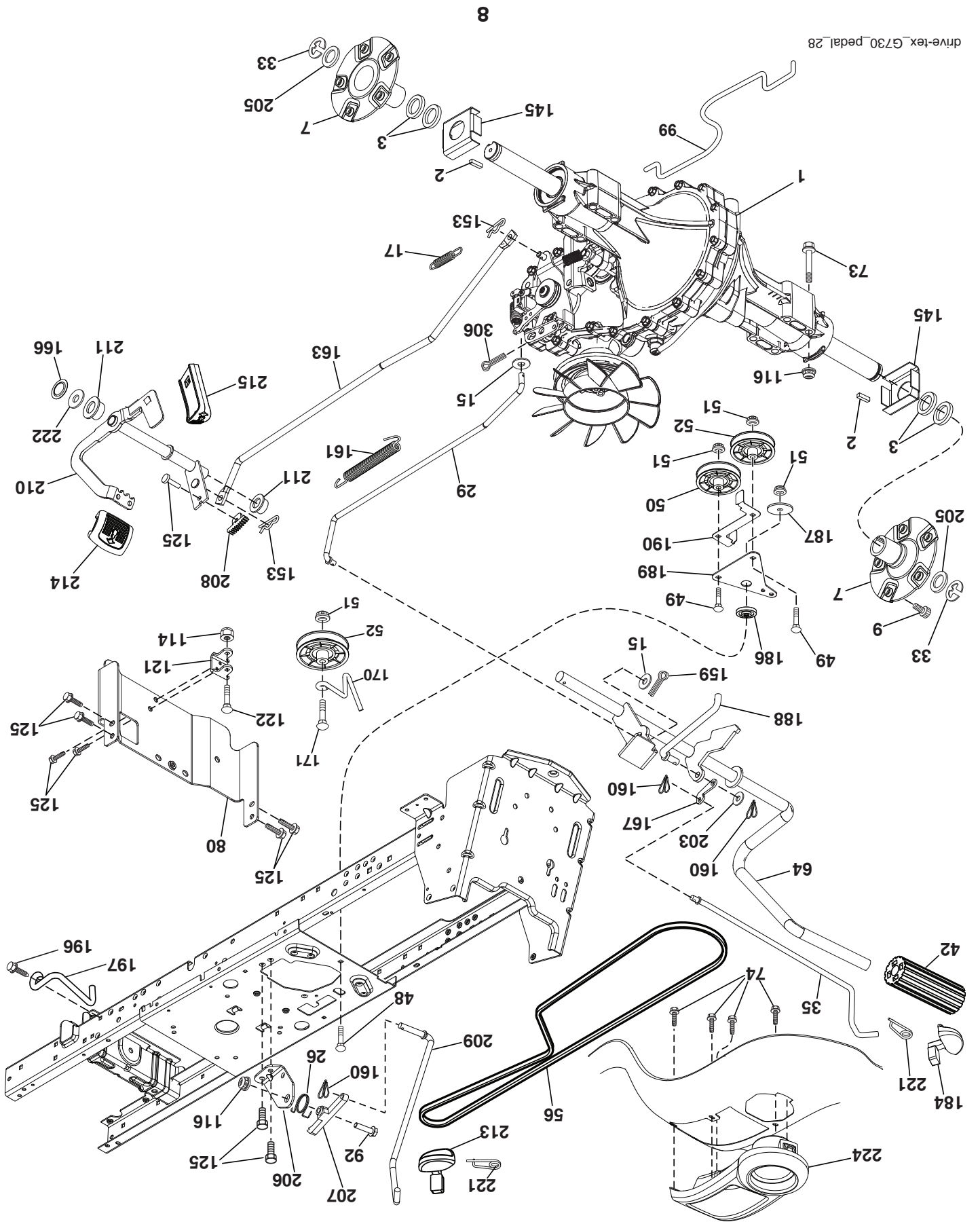

TRACTEUR - - NUMÉRO DE MODÈLE 944.101081

CHÂSSIS/ENCEINTES

NO.	DE	RÉF.	DESCRIPTION
NO.	DE	PIÈCE	
5		580485904	Tableau de bord
14		580354407	Capot
15		580485601	Lentille CG
18		580485302	Calandre
25		580484501	Lentille CD
34		580910801	Plaque de moteur
35		19111116	Rondelle 11/32 x 11/16 x 16 Ja.
36		17060512	Vis 5/16-18 x 3/4
37		400009X428	Aile
52		73680500	Ecrou 5/16-18
58		194314	Support
68		17490508	Vis 5/16-18 x 1/2
102		4497H	Arrêtoir 1"
125		581684801	Pince
130		416358	Vis #10 x .750
137		407590	Pare-Chocs
146		581857901	Boulon
150		580485501	Conduit D'air
151		580663302	Support
152		199535	Deflecteur
161		193097X428	Fenêtre de carburant
162		142432	Vis 1/4 x 1/2
165		196826	Support
175		196304	Pièce d'entretènement
176		400776	Vis 10-24 x 5/8
177		195227	Coussinet
180		195477	Châssis
181		193102X428	Coussinet
182		406859	Tableau de bord
183		74520520	Boulon 5/16-18 x 1-1/4
189		17000512	Vis 5/16-18 x 3/4
191		580485101	Phare/Insert Lentille Réfléchissant CD
194		739000500	Ecrou 5/16-18
195		401556X428	Bouchon
196		420545	Ensemble de la console
198		197300X421	Interrupteur
199		419350	Support
202		580485002	Basse bouclier de garniture CD
203		580484802	Basse bouclier de garniture CG
204		580484701	Ventilation
205		580484207	Ensemble d'angle CD
206		580484107	Ensemble d'angle CG
213		74760512	Boulon 5/16-18 unc x 3/4
218		580897301	Ensemble de capuche pivot
222		137729	Vis 1/4-20 x 5/8
228		195161	Fermeture
235		406129	Entretoise
236		73930500	Ecrou 5/16-18
297		580484901	Phare/Insert Lentille Réfléchissant CG
298		580851001	Ecrou
306		73900600	Ecrou
335		580484602	Panneau de clôture de côté CD
336		580484402	Panneau de clôture de côté CG
350		445143	Pince
363		580724501	Chapeau
364		17060408	Vis
369		421756	Vis #10 x 0.500
-		421264	Pare-chocs

REMARQUE: Toutes les dimensions de composant sont données en pouces E.-U. -- 1 pouce = 25,4 mm

TRACTEUR - - NUMÉRO DE MODÈLE 944.101081
CHÂSSIS/ENCEINTES

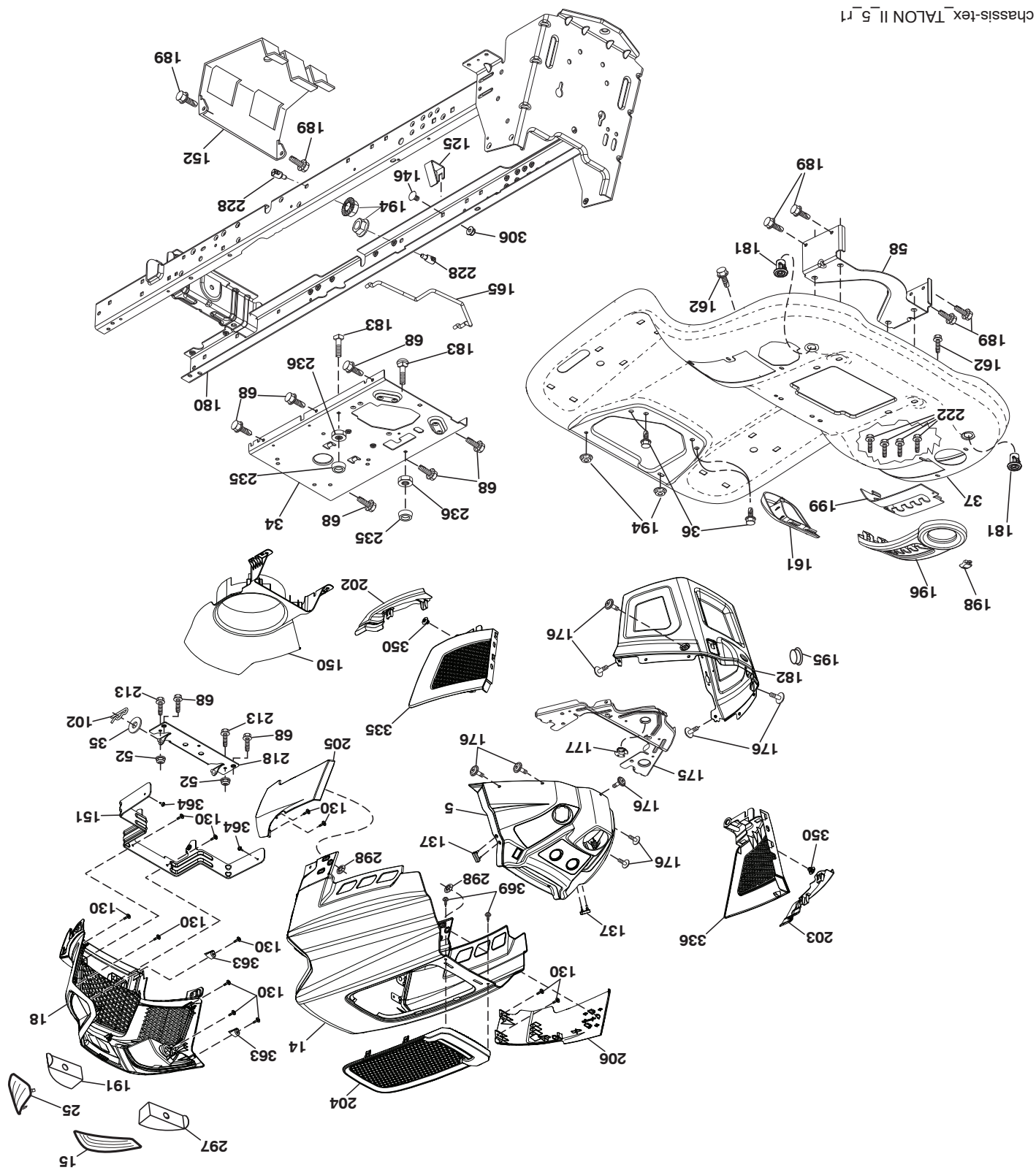

chassis-tex_TALON II_5.r1

TRACTEUR - - NUMÉRO DE MODÈLE 944.101081

ELECTRIQUE

NO.	DÉ	PIÈCE	DESCRIPTION
1		163465	Batterie
2		74760412	Boulon H 1/4-20 unc x 3/4
8		587205101	Bac de batterie
16		176138	Interrupteur de verrouillage pressé
21		400252	Harnais des prises de courant des phares
22		4152J	Ampoule N°1156
24		585555601	Câble de batterie
25		585555501	Câble de batterie de 6 ja. avec un fil de 16 po. - rouge
26		175158	Fusible
27		73510400	Ecrou H 1/4-20 unc
28		416588	Câble de masse de 6 ja. de 21" - noir
29		401545	Interrupteur
30		193350	Contacteur d'allumage
33		411934	Clé/Chaîne
34		110712X	L'Interrupteur des phares
40		501133101	Harnais
41		17720408	Vis 1/4-20 x 1/2
42		131563	Couverture de borne
43		192507	Solénoïde
45		587553902	Ampèremètre rond
46		587554002	Compteur horaire rond
50		174653	Interrupteur, PTO
55		17060512	Vis 5/16-18 x 3/4
71		194276	Harnais des câbles d'allumage
79		175242	Douille ensemble ampoule torsion serrée
90		435395	Couverture
99		17670412	Vis H 1/4-20 x 3/4
100		19091416	Rondelle 9/32 x 7/8 x 16 Ja
141		421225	G700/G730 ROS Entrez le kit

REMARQUE: Toutes les dimensions de composant sont données en pouces E.-U. --1 pouce = 25,4 mm

TRACTEUR - - NUMÉRO DE MODÈLE 944.101081

ELECTRIQUE

T14S-f

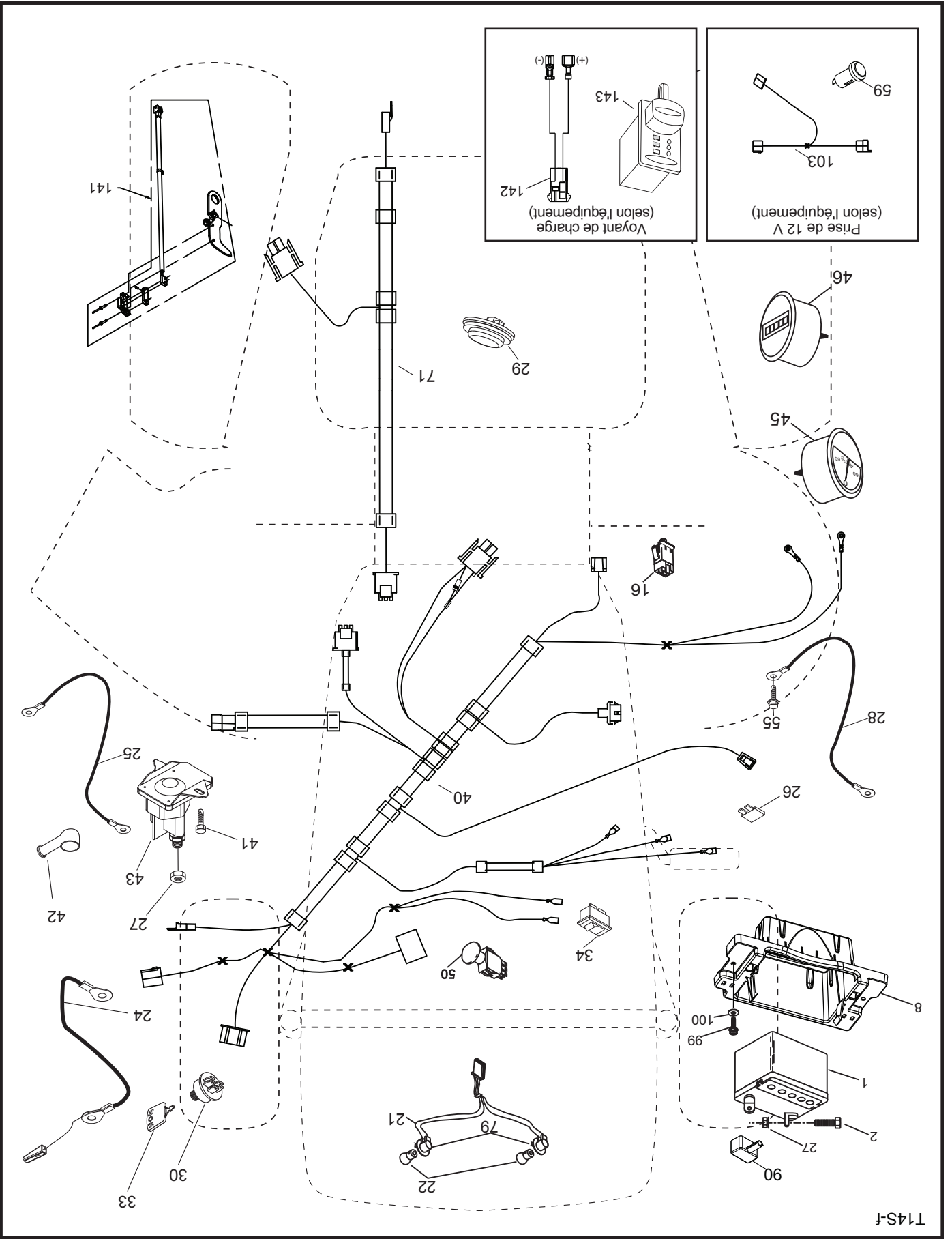

TRACTEUR - - NUMÉRO DE MODÈLE 944.101081

SCHEMA

SC12-F

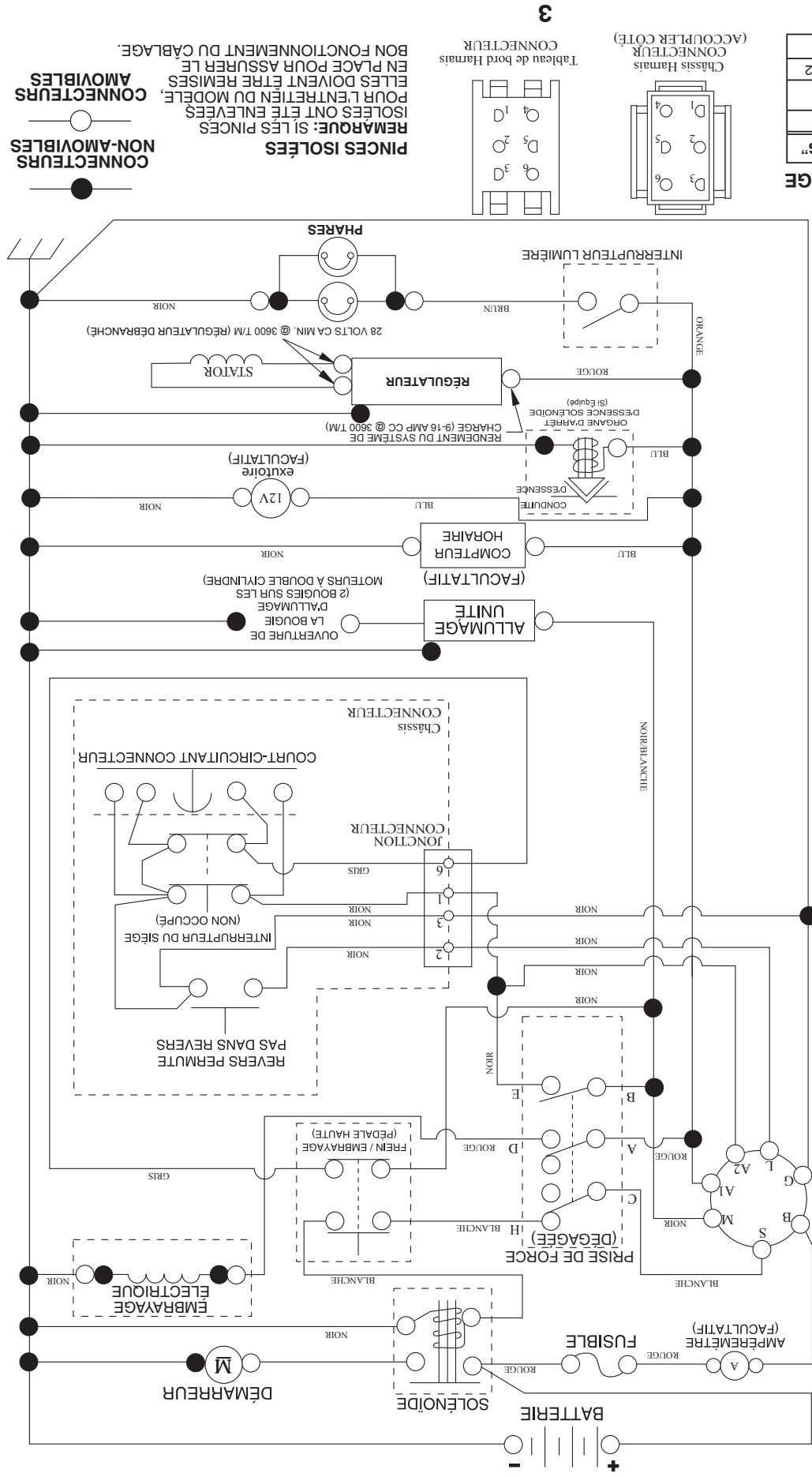

CONTACTEUR D'ALLUMAGE

POSITION	CIRCUIT "FAITS"
ARRÊT	M+G+A1
MARCHE/ALLUMAGE	B+A1
MARCHE	B+A1
DÉMARRAGE	B+S+A1

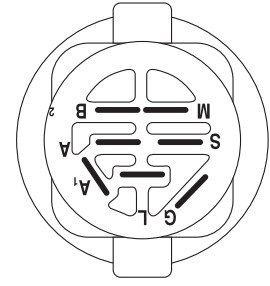

PRISE DE FORCE INTERUPTEUR (ACCOUPLER CÔTÉ)

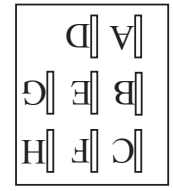

3

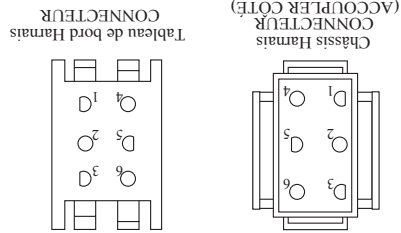

PINCES ISOLÉES
 REMARQUE: SI LES PINCES ISOLÉES ONT ÉTÉ ENLEVÉES, ELLES DOIVENT ÊTRE REMISES EN PLACE POUR ASSURER LE BON FONCTIONNEMENT DU CABLAGE.

CONNECTEURS AMOVIBLES

CONNECTEURS NON-AMOVIBLES

COMMENT UTILISER CE MANUEL

Ce manuel a été dessiné pour fournir le client avec les moyens d'identification des pièces de détails du tracteur quand il/elle a besoin de commander les pièces de rechange. Les illustrations ne peuvent pas représenter exactement le modèle que vous avez acheté. N'utilisez pas ce manuel comme un guide dans le montage et/ou démontage de votre tracteur. La visserie montrée est plus grande pour faciliter l'identification.

Chaque tracteur a un numéro de modèle particulier.

Le numéro de modèle du produit se trouvera sur l'aile, dessous le siège.

Lorsque vous commandez des pièces de rechange, donnez toujours les renseignements suivants:

- Produit - "TRACTEUR"
- NUMÉRO DU MODÈLE - "944.101081"
- Numéro de la Pièce
- Description de la Pièce

TABLE DE MATIERES

SCHEMA.....	3
ELECTRIQUE.....	4-5
CHASSIS/ENCEINTES.....	6-7
ENTRAÎNEMENT.....	8-9
MOTEUR.....	10-11
ENSEMBLE DE LA DIRECTION.....	12-13
CARTER DE TONDEUSE.....	14-15
LEVAGE DE LA TONDEUSE.....	16-17
ENSEMBLE DU SIÈGE.....	18
DÉCALCOMANIES.....	19
VOYEZ LES DÉTAILS DE TRANSMISSION.....	20-21
VOYEZ LES DÉTAILS DE MOTOR.....	22-33
GARANTIE.....	35
ENTRETIEN DE "SEARS".....	36

Sears Canada, Inc., Toronto, Ontario M5B 2B8

* La puissance nominale indiquée par le fabricant du moteur est la puissance brute moyenne (à un régime en tr/min spécifique) d'un moteur de production type pour le modèle de moteur mesuré selon les normes SAE pour la puissance brute du moteur. Se reporter au fabricant du moteur pour tous les détails.

**26,0 C.V.*
DÉMARRAGE ÉLECTRIQUE
TONDEUSE DE 137 CM (54 PO.)
AUTOMATIQUE
TRACTEUR DE JARDIN**

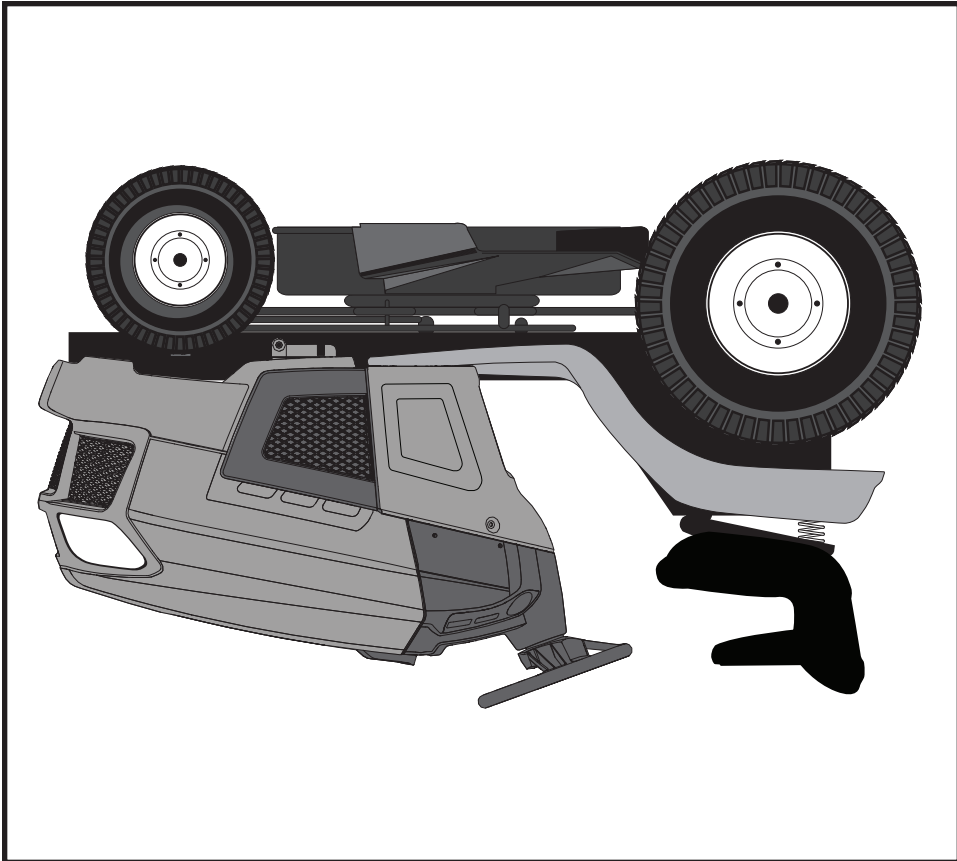

IMPORTANT:
Lisez et suivez le
mode d'emploi et
toutes les règles
de sécurité avant
d'utiliser cet
équipement

**NUMÉRO DE
MODÈLE
944.101081**

**SEARS
MANUEL DES
PIÈCES DE
RECHANGE**