

# **Operator's manual**

## **iZ 21**

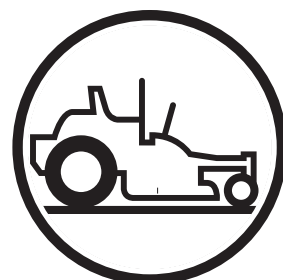

Please read these instructions carefully and make sure you understand them before using the machine.

**English**



---

# OPERATOR S MANUAL

---

## RIDER

### iZ SERIES

#### Contents

<b>Contents</b> .....	<b>1</b>	<b>Maintenance</b> .....	<b>35</b>
<b>Introduction</b> .....	<b>3</b>	Maintenance Schedule.....	35
Congratulations.....	3	Battery.....	37
General .....	3	Ignition System.....	38
Driving and Transport on Public Roads .....	3	Checking the Safety System .....	39
Towing .....	3	Checking the Engine's Cooling Air Intake .....	41
Operating .....	3	Checking and Adjusting the Throttle Cable.....	41
Good Service .....	4	Checking and Adjusting the Choke Cable.....	41
Manufacturing Number .....	4	Replacing the Air Filter.....	42
<b>Symbols and Decals</b> .....	<b>5</b>	Cyclon air filter maintenance.....	43
<b>Safety Instructions</b> .....	<b>7</b>	Replacing the Fuel Filter .....	45
General Use.....	7	Checking the Fuel Pump s Air Filter.....	45
Personal Safety Equipment .....	9	Checking Tire Pressures.....	46
Driving on Slopes.....	9	Checking the Parking Brake.....	46
Children.....	10	Checking the V-belts .....	46
Maintenance .....	11	Checking the Blades .....	47
Transport.....	14	Adjusting the Mower Deck .....	49
Customer responsibilities.....	15	Cleaning and Washing.....	51
<b>Controls</b> .....	<b>16</b>	Caster Wheels.....	51
Control Locations .....	16	Hardware.....	51
1. Motion Control Levers.....	17	<b>Lubrication</b> .....	<b>52</b>
2. Hour Meter .....	18	Lubrication Schedule.....	52
3. Tracking knob .....	18	General .....	52
4. Parking Brake .....	18	Lubricating the Cables .....	53
5. Blade switch.....	19	Shaft Bushings and Linkage .....	53
6. Ignition Switch.....	19	Lubricating in Accordance with the	
7. Fuses .....	19	Lubrication Schedule.....	53
8. Seat Locking Device .....	20	<b>Trouble Shooting Guide</b> .....	<b>60</b>
9. Refueling.....	20	<b>Storage</b> .....	<b>62</b>
10. Fuel Shut Off Valve.....	21	Winter Storage .....	62
11. Seat Adjustment Lever.....	21	Service .....	62
12. Choke Control .....	21	<b>Wiring diagram</b> .....	<b>63</b>
13. Throttle Control .....	22	<b>Technical Data</b> .....	<b>64</b>
14. Lifting Lever for the Mower Deck .....	22	Accessories.....	66
Pump release valves.....	23	Torque Specifications.....	66
Accessories.....	23	<b>Conformity Certificates</b> .....	<b>67</b>
<b>Operation</b> .....	<b>24</b>	USA requirements.....	67
Training .....	24	EU declaration of conformity .....	67
Roll bar and safety belt .....	25	<b>Service Journal</b> .....	<b>68</b>
Before Starting .....	25	Delivery Service .....	68
Starting the Engine .....	25	After the First 8 Hours .....	69
To start an engine with a weak battery .....	29	25-Hour Service .....	70
Running.....	30	50-Hour Service .....	71
Operating on hills .....	31	100-Hour Service .....	72
Mowing Tips.....	32	300-Hour Service .....	73
Stopping the Engine.....	33	At Least Once Each Year.....	74
Moving by Hand.....	34		



**WARNING!**

Failure to follow cautious operating practices can result in serious injury to the operator or other persons. The owner must understand these instructions, and must allow only trained persons who understand these instructions to operate the mower. Each person operating the mower must be of sound mind and body and must not be under the influence of any mind altering substance.

---

# INTRODUCTION

---

## Introduction

### Congratulations

Thank you for purchasing a Husqvarna ride-on mower. This machine is built for the greatest efficiency and rapid mowing primarily of large areas. Controls in one place and a hydrostatic transmission regulated by steering controls also contribute to the machine's performance.

This manual is a valuable document. Following the instructions (use, service, maintenance, etc.) by all who operate this machine can considerably increase the lifespan of your machine and even increase its resale value. It is also very important to follow the instructions for the safety of you and others.

If you sell your machine, be sure to give the operator's manual to the new owner.

The final chapter of this operator's manual comprises a Service Journal. Ensure that service and repair work is documented. A well kept service journal reduces service costs for the season-based maintenance and affects the machine's resale value. Take the operator's manual along when the machine is left at the workshop for service.

### General

In this operator's manual, left and right, backward and forward are used in relation to the machine's normal driving direction.

Continuous dedication to improve our products require that specifications and design are subject to change without notice.

### Driving and Transport on Public Roads

Check applicable road traffic regulations before transporting on public roads. If the machine is transported, you must always use approved fastening equipment and ensure that the machine is well anchored. DO NOT operate this machine on public roadways.

### Towing

Do not tow this machine, it may cause damage to the drive system.

Do not tow any trailers, etc with this mower. They may jackknife or overturn causing damage to the mower and possibly serious injury to the operator.

### Operating

This machine is constructed only for mowing grass on lawns and other free and even ground without obstacles such as stones, tree stumps, etc. The machine can also be used for other tasks when equipped with special accessories provided by the manufacturer, for which the operating instructions are provided in conjunction with delivery. All other types of use are incorrect. The manufacturer's directions concerning operation, maintenance, and repairs must be carefully followed.

Lawnmowers and all power equipment, can be potentially dangerous if used improperly. Safety requires good judgement, careful use in accordance with these instructions and common sense.

The machine must only be operated, maintained, and repaired by persons that are familiar with the machine's special characteristics and who are well versed in the safety instructions. Use only approved repair parts to maintain this machine.

Accident prevention regulations, other general safety regulations, occupational safety rules, and traffic regulations must be followed without fail.

Unauthorized modifications to the design of the machine may absolve the manufacturer from liability for any resulting personal injury or property damage.

---

# INTRODUCTION

---

## Good Service

Husqvarna's products are sold all over the world and only in specialized retail stores with complete service. This ensures that you as a customer receive only the best support and service. Before the product is delivered, the machine has, for example, been inspected and adjusted by your retailer, see the certificate in the Service Journal in this operator's manual.

When you need spare parts or support in service questions, warranty issues, etc., please consult the following professional:

This Operator's Manual belongs to the machine with manufacturing number:	Engine	Transmission

## Manufacturing Number

The machine's manufacturing number can be found on the printed plate affixed to the left in the engine compartment. Stated on the plate, from the top are:

- The machine's type designation (I.D.).
- The manufacturer's type number (Model).
- The machine's serial number (Serial no.)

Please state the type designation and serial number when ordering spare parts.

The engine's manufacturing number is stated on a barcode decal. This is placed on the left side of the crankcase, in front of the starter. The plate states:

- The engine's serial number (E/NO).
- The engine's type designation (Code).

Please state these when ordering spare parts.

The hydraulic pump's manufacturing number is stated on a barcode decal affixed to the left side of the pump housing. The plate states:

- The pump's type designation.
- The pump's serial number.

The hydraulic motor's manufacturing number is stated on a round metal plate. This is placed on the gable inside the motor. The plate states:

- The hydraulic motor's type designation and design version.
- The hydraulic motor's serial number.

# SYMBOLS AND DECALS

## Symbols and Decals

These symbols are found on the machine and in the operator s manual. Study them carefully so that you know what they mean.



Used in this publication to notify the reader of a risk of **personal injury or death**, particularly if the reader should neglect to follow instructions given in the manual.



Used in this publication to notify the reader of a risk of **material damage**, particularly if the reader should neglect to follow instructions given in the manual. Used also when there is a potential for misuse or misassembly.

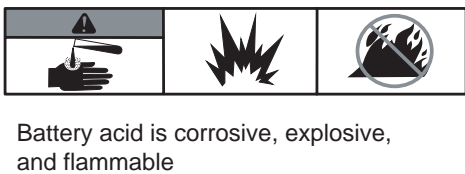
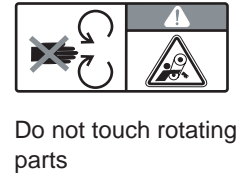
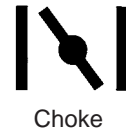

# SYMBOLS AND DECALS

Read  
Operator's  
Manual.

Shut off engine  
& remove key  
before  
performing any  
maintenance or  
repair work.

Keep a safe  
distance from  
the machine.

Use on  
slopes no  
greater  
than 10°.

No  
passengers



Whole body  
exposure to  
thrown  
objects.

Severing of  
fingers &  
toes.

Do not open  
or remove  
safety shields  
while engine  
is running.

Careful  
backing up,  
watch for other  
people.

Careful going  
forward, watch  
for other people.



Moving sharp blades  
under cover



# SAFETY INSTRUCTIONS

## Safety Instructions

These instructions are for your safety. Read them carefully.



### WARNING!

This symbol means that important safety instructions need to be emphasized. It concerns your safety.

**IMPORTANT:** THIS CUTTING MACHINE IS CAPABLE OF AMPUTATING HANDS AND FEET AND THROWING OBJECTS. FAILURE TO OBSERVE THE FOLLOWING SAFETY INSTRUCTIONS COULD RESULT IN SERIOUS INJURY OR DEATH.

### General Operation

- Read, understand, and follow all instructions on the machine and in the manual before starting.
- Do not put hands or feet near rotating parts or under the machine. Keep clear of the discharge opening at all times.
- Only allow responsible adults, who are familiar with the instructions, to operate the machine.
- Clear the area of objects such as rocks, toys, wire, etc., which could be picked up and thrown by the blades.
- Be sure the area is clear of bystanders before operating. Stop machine if anyone enters the area.
- Never carry passengers. The machine is only intended for use by one person.
- Do not mow in reverse unless absolutely necessary. Always look down and behind before and while backing.
- Never direct discharged material toward anyone. Avoid discharging material against a wall or obstruction. Material may ricochet back toward the operator. Stop the blades when crossing gravel surfaces.
- Do not operate machine without the entire grass catcher, discharge guard, or other safety devices in place and working.
- Slow down before turning.
- Never leave a running machine unattended. Always turn off blades, set parking brake, stop engine, and remove keys before dismounting.

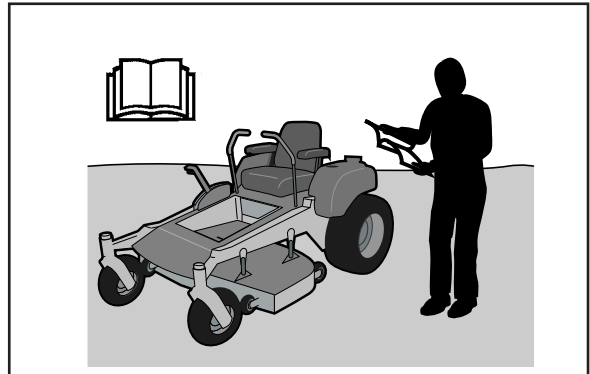

8011-512

*Read the operator's manual before starting the machine*

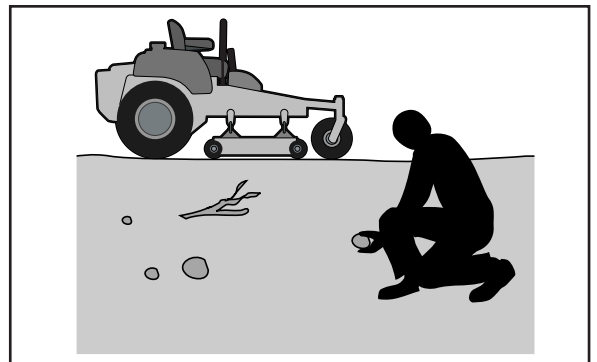

8011-513

*Clear the area of objects before mowing*



8011-520

*Never take passengers*

---

# SAFETY INSTRUCTIONS

---

- Disengage blades when not mowing. Shut off engine and wait for all parts to come to a complete stop before cleaning the machine, removing the grass catcher, or unclipping the discharge guard.
- Operate machine only in daylight or good artificial light.
- Do not operate the machine while under the influence of alcohol or drugs.
- Watch for traffic when operating near or crossing roadways.
- Use extra care when loading or unloading the machine into a trailer or truck.
- Always wear eye protection when operating machine.
- Data indicates that operators, age 60 years and above, are involved in a large percentage of riding mower-related injuries. These operators should evaluate their ability to operate the riding mower safely enough to protect themselves and others from serious injury.
- Follow the manufacturer's recommendation for wheel weights or counterweights.
- Anyone who operates this machine must first read and understand this Operation Manual. Local laws may regulate the age of the user.
- Keep machine free of grass, leaves or other debris build-up which can touch hot exhaust / engine part and burn. Do not allow the mower deck to plow leaves or other debris which can cause build-up to occur. Clean any oil or fuel spillage before operating or storing the machine. Allow machine to cool before storage.



## **WARNING!**

**Engine exhaust and certain vehicle components contain or emit chemicals considered to cause cancer, birth defects, or other reproductive system damage. The engine exhaust contains carbon monoxide, which is a odorless, colorless, poisonous gas. Do not use the machine in enclosed spaces.**

# SAFETY INSTRUCTIONS

## Personal Safety Equipment



### WARNING!

When using the machine, approved personal protective equipment (shown in illustrations) shall be used. Personal protective equipment cannot eliminate the risk of injury but it will reduce the degree of injury if an accident does happen. Ask your retailer for help in choosing the right equipment.

- Make sure that you have first aid equipment close at hand when using the machine.
- Never use the machine when barefoot. Always wear protective shoes or boots, preferably with steel toecaps.
- Always wear approved protective glasses or a full visor when assembling or driving.
- Always wear gloves when handling the blades.
- Never wear loose clothing that can get caught in moving parts.
- Use ear protectors to avoid damage to hearing.

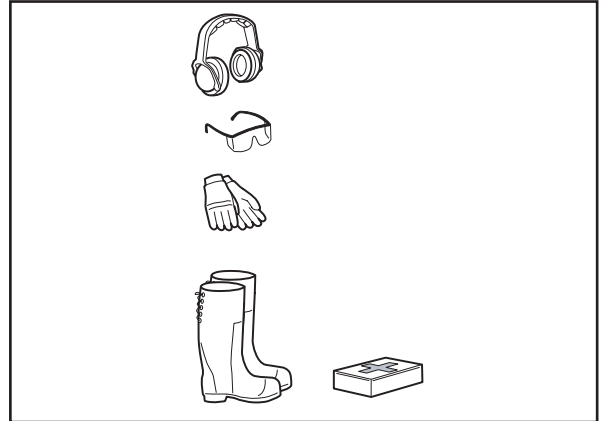

8011-670

*Personal protective equipment*

## Slope Operation

Slopes are a major factor related to loss of control and tip-over accidents, which can result in severe injury or death. Operation on all slopes requires extra caution. If you cannot back up the slope or if you feel uneasy on it, do not mow it.

- Mow up and down slopes (10 degrees maximum), not across.
- Watch for holes, ruts, bumps, rocks, or other hidden objects. Uneven terrain could overturn the machine. Tall grass can hide obstacles.
- Choose a low ground speed so that you will not have to stop while on the slope.
- Do not mow on wet grass. Tires may lose traction.
- Avoid starting, stopping, or turning on a slope. If the tires lose traction, disengage the blades and proceed slowly straight down the slope.
- Keep all movement on the slopes slow and gradual. Do not make sudden changes in speed or direction, which could cause the machine to roll over.

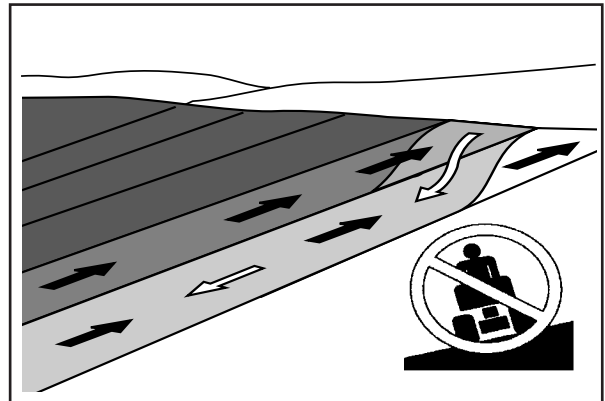

6003-004

*Mow up and down, not side-to-side*



### WARNING!

Do not drive up or down hills with slopes greater than 10 degrees. And do not drive across any slopes.

# SAFETY INSTRUCTIONS

- Use extra care while operating machine with grass catchers or other attachments; they can affect the stability of the machine. Do not use on steep slopes.
- Do not try to stabilize the machine by putting your foot on the ground.
- Do not mow near drop-offs, ditches, or embankments. The machine could suddenly roll over if a wheel is over the edge or if the edge caves in.



8011-519

*Be extra cautious when driving on slopes*

## Children

Tragic accidents can occur if the operator is not alert to the presence of children. Children are often attracted to the machine and the mowing activity. *Never* assume that children will remain where you last saw them.

- Keep children out of the mowing area and in the watchful care of a responsible adult other than the operator.
- Be alert and turn machine off if a child enters the area.
- Before and while backing, look behind and down for small children.
- Never carry children, even with the blades shut off. They may fall off and be seriously injured or interfere with safe machine operation. Children who have been given rides in the past may suddenly appear in the mowing area for another ride and be run over or backed over by the machine.
- Never allow children to operate the machine.
- Use extra care when approaching blind corners, shrubs, trees, or other objects that may block your view of a child.

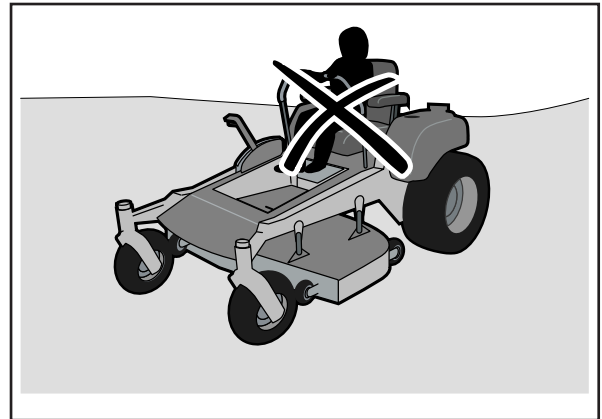

8011-517

*Never allow children to operate the machine*



8011-518

*Keep children away from the work area*

# SAFETY INSTRUCTIONS

## Maintenance



### WARNING!

The engine must not be started when the driver's floor plate or any protective plate for the mower deck's drive belt is removed.

## Safe Handling of Gasoline

To avoid personal injury or property damage, use extreme care in handling gasoline. Gasoline is extremely flammable and the vapors are explosive.

- Extinguish all cigarettes, cigars, pipes, and other sources of ignition.
- Use only approved gasoline container.
- Never remove gas cap or add fuel with the engine running. Allow engine to cool at least two (2) minutes before refueling.
- Never fuel the machine indoors.
- Never store the machine or fuel container where there is an open flame, spark, or pilot light such as on a water heater or other appliances.
- Before you begin refueling, minimize the risk of static electricity by touching a metal surface.
- Never fill containers inside a vehicle or on a truck or trailer bed with plastic liner. Always place containers on the ground away from your vehicle when filling.
- Remove gas-powered equipment from the truck or trailer and refuel it on the ground. If this is not possible, then refuel such equipment with a portable container, rather than from a gasoline dispenser nozzle.
- Keep the nozzle in contact with the rim of the fuel tank or container opening at all times until fueling is complete. Do not use a nozzle lock-open device.
- If fuel is spilled on clothing, change clothing immediately.
- Never overfill fuel tank. Replace gas cap and tighten securely.
- Do not start the engine near spilled fuel.
- Never use gasoline as a cleaning agent.
- If leaks arise in the fuel system, the engine must not be started until the problem has been resolved.
- Check the fuel level before each use and leave space for the fuel to expand, because the heat from the engine and the sun may otherwise cause the fuel to expand and overflow.

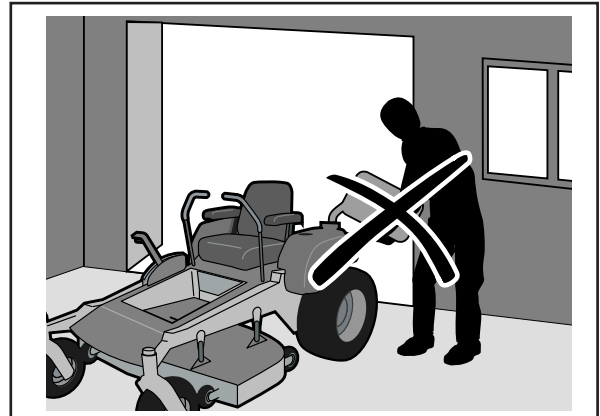

8011-516

*Never fill the fuel tank indoors*



### WARNING!

The engine and the exhaust system, become very hot during operation.

Risk for burns if touched.

Allow engine and exhaust system to cool at least two (2) minutes before refueling.

# SAFETY INSTRUCTIONS

## General Maintenance

- Never operate machine in a closed area.
- Keep all nuts and bolts tight to be sure the equipment is in safe working condition.
- Never tamper with safety devices. Check their proper operation regularly.
- Keep machine free of grass, leaves, or other debris build-up. Clean oil or fuel spillage and remove any fuel-soaked debris. Allow machine to cool before storing.
- If you strike a foreign object, stop and inspect the machine. Repair, if necessary, before restarting.
- Never make any adjustments or repairs with the engine running.
- Check grass catcher components and the discharge guard frequently and replace with manufacturer's recommended parts, when necessary.
- Mower blades are sharp. Wrap the blade or wear gloves, and use extra caution when servicing them.
- Check brake operation frequently. Adjust and service as required.
- Maintain or replace safety and instruction labels, as necessary.
- Do not modify safety equipment. Check regularly to be sure it works properly. The machine must not be driven with defective or unmounted protective plates, protective cowlings, safety switches, or other protective devices.
- Do not change the settings of governors and avoid running the engine with overly high engine speeds. If you run the engine too fast, you risk damaging the machine components.
- Be very careful when handling battery acid. Acid on skin can cause serious corrosive burns. If you spill battery acid on your skin, rinse immediately with water.
- Acid in the eyes can cause blindness, contact a doctor immediately.

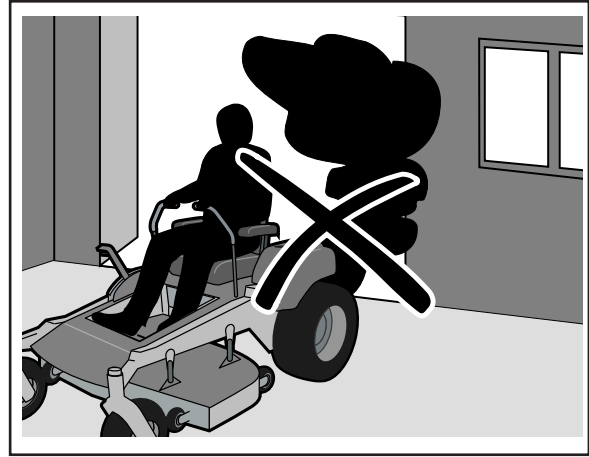

8011-515

*Never drive the machine in an enclosed space*



**Always use protective glasses when handling the battery.**



### **WARNING!**

**The battery contains lead and lead compounds, chemicals that are considered to cause cancer, birth defects, and other reproductive system damage. Wash your hands after handling the battery.**

# SAFETY INSTRUCTIONS

- Be careful when servicing the battery. Explosive gases form in the battery. Never perform maintenance on the battery when smoking or near open flames or sparks. The battery can explode and cause serious injury/damage.
- Ensure that nuts and bolts, especially the fastening bolts for the blade attachments, are properly tightened, torqued and that the equipment is in good condition.
- Do not modify safety equipment. Check regularly to be sure it works properly. The machine must not be driven with defective or unmounted protective plates, protective cowlings, safety switches, or other protective devices.
- Do not change the settings of governors and avoid running the engine with overly high engine speeds. If you run the engine too fast, you risk damaging the machine components.
- Sparking can occur when working with the battery and the heavy cables of the starter circuit. This can cause battery explosion, fire or eye injury. Sparking in this circuit can not occur after the chassis cable (normally negative, black) is removed from the battery.

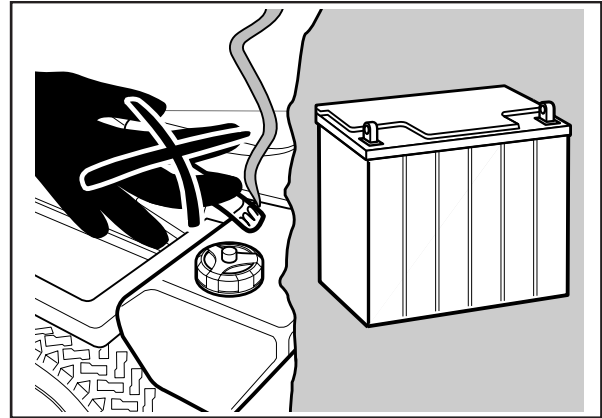

6003-009

*Do not smoke when performing maintenance on the battery. The battery can explode and cause serious injury/damage*

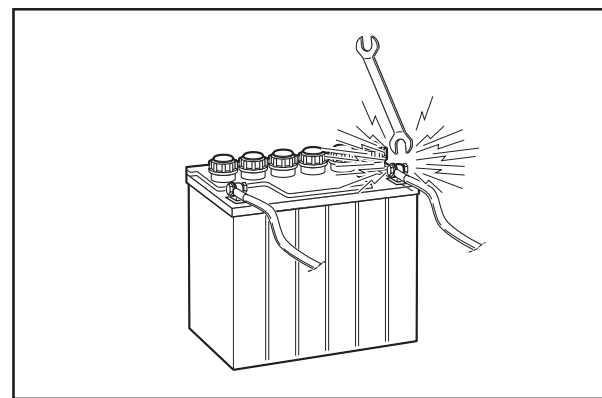

8009-728

*Risk of sparking*



## **WARNING!**

**Avoid electrical sparking and its consequences by the following routines:**

- Use protective goggles.
- Ensure that the fuel filler cap is mounted tightly and no flammable substances is stored in an open vessel.
- Never work with the starter circuit if there is spilled fuel.
- Disconnect the chassis cable from the battery first and reconnect it last.
- Do not make a bridge short circuit across the starter relay to run the starter.
- Never use the machine indoors or in spaces lacking proper ventilation. The exhaust fumes contain carbon monoxide, an odorless, poisonous, and lethal gas.
- Stop and inspect the equipment if you run over or into anything. If necessary, make repairs before starting.



# SAFETY INSTRUCTIONS

- Never make adjustments with the engine running.
- The machine is tested and approved only with the equipment originally provided or recommended by the manufacturer. Only use approved repair parts for the machine.
- The blades are sharp and can cause cuts and gashes. Wrap the blades or use protective gloves when handling them.
- Check the parking brake's functionality regularly. Adjust and service as necessary.
- The mulch blades should only be used in familiar areas when higher quality mowing is desired.
- Reduce the risk of fire by removing grass, leaves, and other debris that may have accumulated on the machine. Allow the machine to cool before putting it in storage.
- Regularly clean deck and underside of deck, avoid spraying engine and electrical components with water.



8011-644

*Clean the machine regularly*

## Transport

- The machine is heavy and can cause serious crushing injuries. Be extra cautious when it is loaded on or unloaded from a vehicle or trailer.
- Use an approved trailer to transport the machine. Activate the parking brake, turn off the fuel supply, and fasten the machine with approved fastening devices, such as bands, chains, or straps, when transporting.
- Do not operate this machine on public roadways.
- Check and abide by local traffic regulations before transporting the machine on any road.
- Do not tow this machine, it may cause damage to the drive system.
- Do not tow any trailers, etc. with this mower. They may jackknife or overturn causing damage to the mower and possibly serious injury to the operator.

### **IMPORTANT INFORMATION**

**The parking brake is not sufficient to lock the machine in place during transport. Ensure that the machine is well fastened to the transport vehicle. Always reverse the machine onto the transport vehicle to avoid tipping it over.**



---

# SAFETY INSTRUCTIONS

---

## Customer responsibilities

- Read and observe the safety rules.
- Follow a regular schedule in maintaining, caring for and using your mower.
- Follow the instructions under "Maintenance" and "Storage" sections of this owner's manual.
- This machine has no brain. Use yours!



### **WARNING!**

**This mower is equipped with an internal combustion engine and should not be used on or near any unimproved forest-covered, bush-covered or grass-covered land unless the engine's exhaust system is equipped with a spark arrester meeting applicable local or state laws (if any). If a spark arrester is used, it should be maintained in effective working order by the operator.**

A spark arrester for the muffler is available through your authorized Husqvarna dealer.

# CONTROLS

## Controls

This operator's manual describes the Husqvarna Zero Turn Rider. The rider is fitted with a Kawasaki four-stroke V-Twin engine developing 21 horse power.

Transmission from the engine is made via two belt-driven hydrostat transaxles, which in turn drive a hydraulic motor for each drive wheel. Using the left and right steering controls, the flow is regulated and thereby the direction and speed.

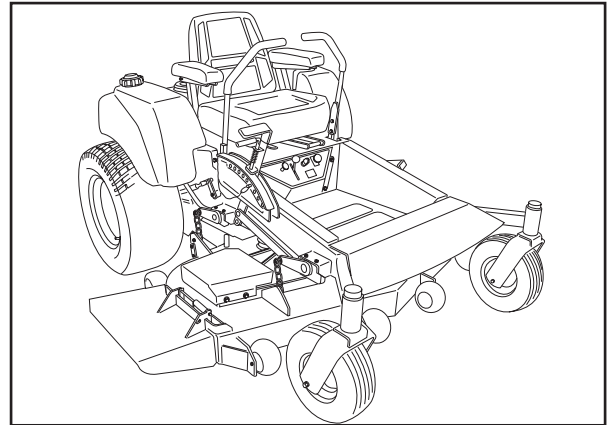

8011-583

Zero Turn Rider

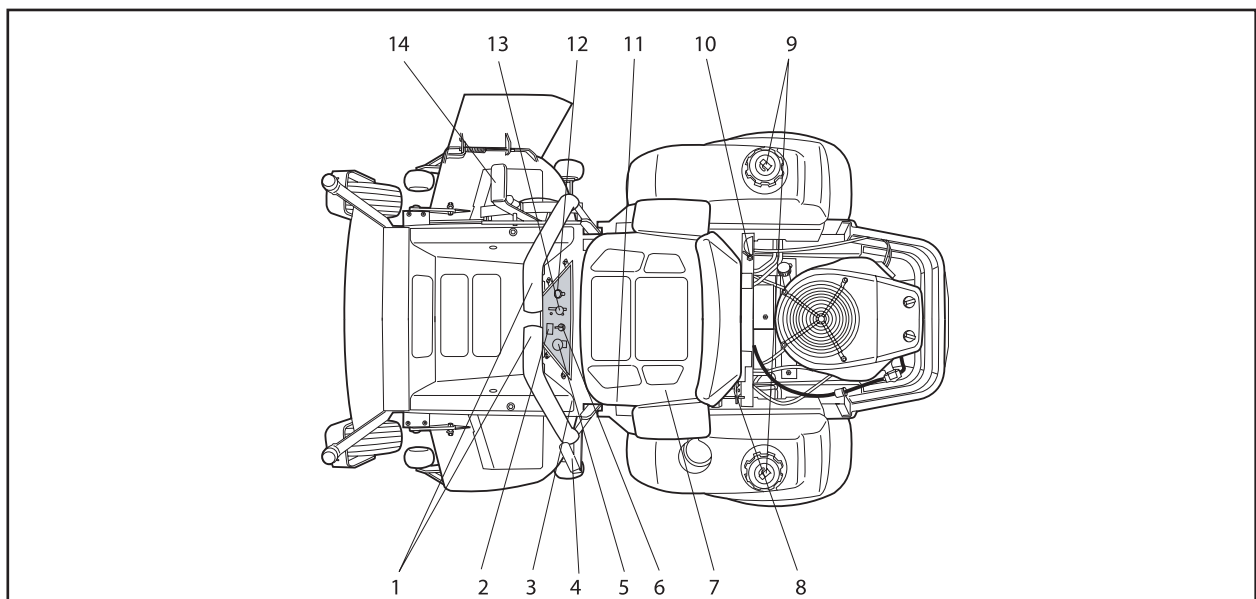

8011-767

Locations of the controls

## Control Locations

	Page		Page
1. Motion control, left and right	17	8. Seat locking device	20
2. Hour meter	18	9. Fuel tank cap	20
3. Tracking knob	18	10. Fuel shut off valve	21
4. Parking brake	18	11. Seat adjustment lever	21
5. Blade-switch	19	12. Choke control	21
6. Ignition switch	19	13. Throttle control	22
7. Fuses	19	14. Lifting lever, mower deck	22

# CONTROLS

## 1. Motion Control Levers

The machine's speed and direction are continuously variable using the two steering controls. The steering controls can be moved forward or backward about a neutral position. Furthermore, there is a neutral position, which is locked if the steering controls are moved outward.

When both controls are in the neutral position (N), the machine stands still.

By moving both controls an equal amount forward or backward, the machine moves in a straight line forward or backward respectively.

In order, for example, to turn right while moving forward, move the right control towards the neutral position. The rotation of the right wheel is reduced and the machine turns to the right.

Zero turn can be achieved by moving one control backward (behind the neutral position) and carefully moving the other steering control forward from its neutral position. The rotation direction when zero turning is determined by which steering control is moved backward behind the neutral position. If the left steering control is pulled backward, the machine turns to the left. Use extra care when using this maneuver.

If the steering controls are in uneven positions when standing still they can be adjusted using the adjustment screws for the steering lever, not the link system, for the controls.

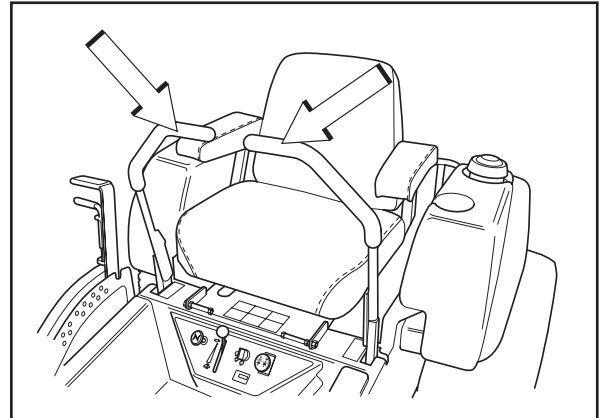

8011-788

Steering controls



### WARNING!

The machine can turn very rapidly if one steering control is moved much further forward than the other.

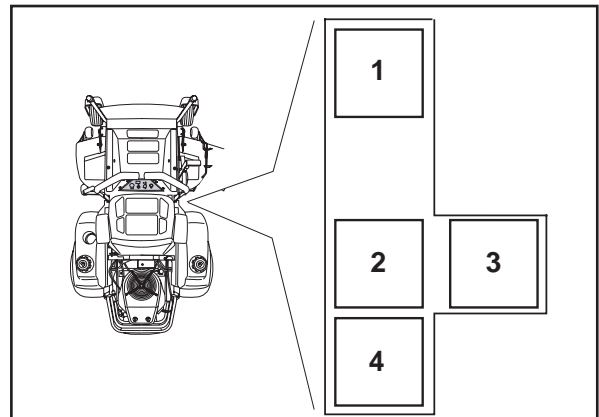

8011-791

- 1 Forward
- 2 Neutral
- 3 Neutral slot, Neutral lock
- 4 Reverse

Motion control lever pattern (right side)

# CONTROLS

## 2. Hour Meter

The hour meter displays the total operating time.

It will flash CHG OIL (Change Oil) at 50 hour intervals. The flash duration is one hour before and one hour after the interval. The CHG OIL icon will come on and shut off automatically. The hour meter can not be manually reset.

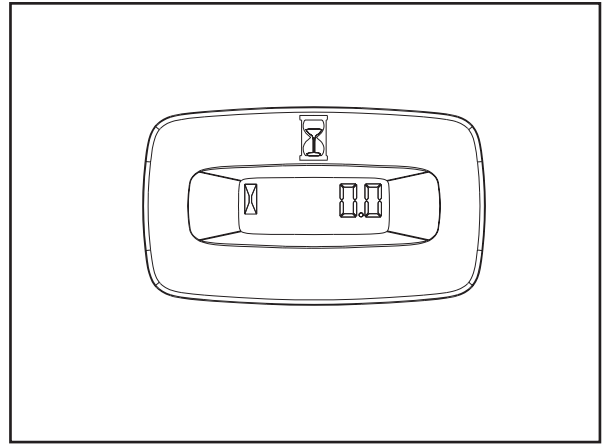

hourmeter

*Hour meter*

## 3. Tracking Knob

The tracking knob is located in front of the left control lever. Rotating this knob allows fine tuning adjustments so that the machine tracks straight with the drive levers in the full forward position.

Rotate the knob clockwise (as viewed from the operating position) to increase the speed or counterclockwise to decrease the speed on the left control lever. Example: If control levers are full forward and the unit turns to the right, turn the tracking knob counterclockwise to decrease the speed on the left control lever.

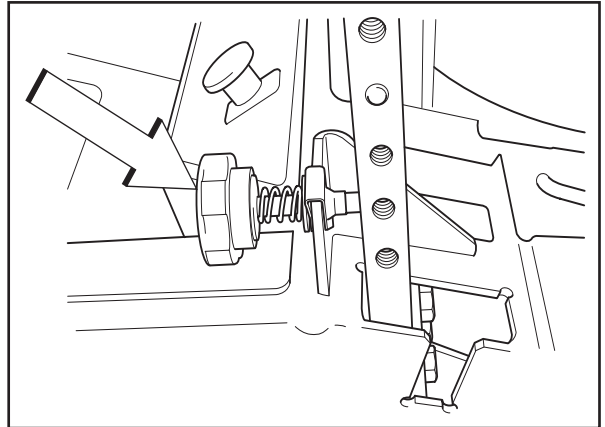

8011-442

*Tracking knob*

## 4. Parking Brake

The parking brake is found on the left of the machine. Pull the lever backward to activate the brake and forward to release it.

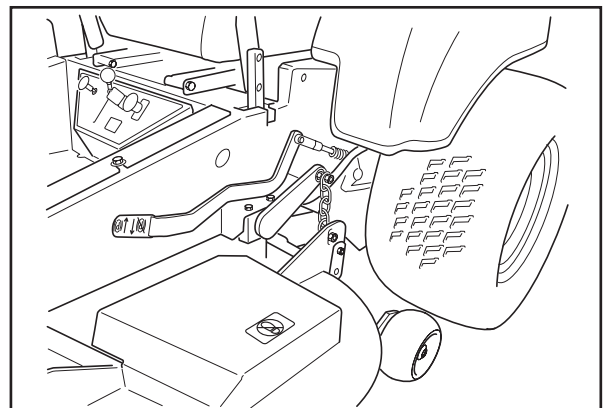

8011-511

*Parking brake not activated*

# CONTROLS

## 5. Blade switch

In order to engage the mower deck, pull the knob out; the mower blades are disengaged when the knob is depressed.

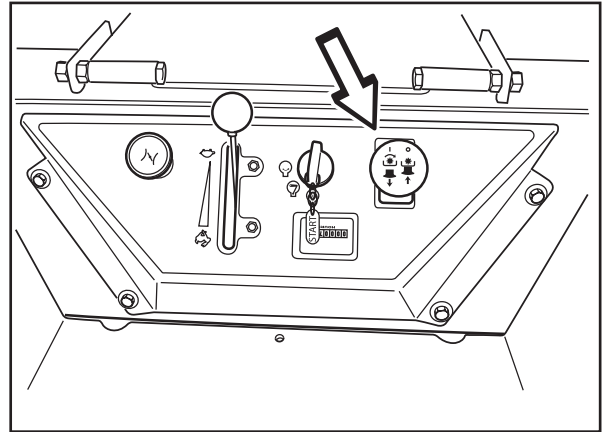

8011-510

Blade Switch

## 6. Ignition Switch

The ignition key is placed in the ignition switch on the driver's panel and is used to start and stop the engine.

### IMPORTANT INFORMATION

**Do not run the starter for more than five seconds each time. If the engine does not start, wait about 10 seconds before re-trying.**

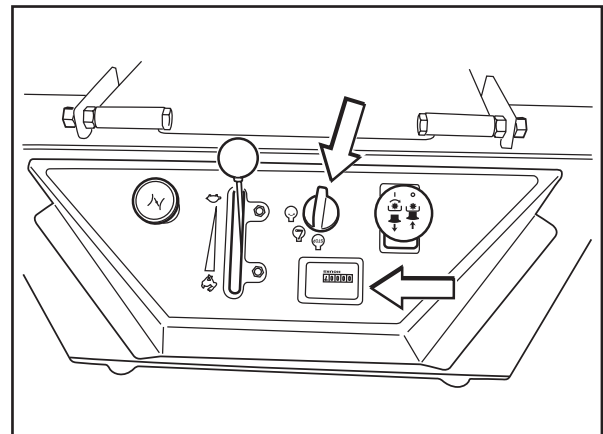

8011-521

Ignition key and hour meter

## 7. Fuses

The fuses are located in a holder to the left of the hydraulic tank. They are flat pin fuses of the same type used in automobiles.

There are three fuses, as well as socket for one spare fuse.

Fuse ratings and functions:

- ¥ 20 A, Primary fuse.
- ¥ 7.5 A, Mower deck coupling.
- ¥ 7.5.A, Accessory outlet.
- ¥ Socket for spare fuse.

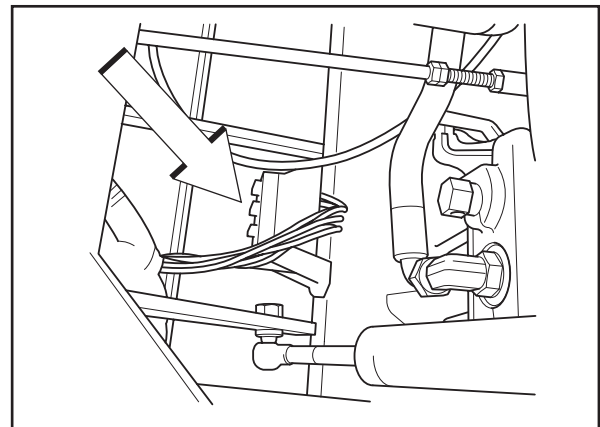

8011-443

Fuses

# CONTROLS

## 8. Seat Locking Device

Under the rear part of the seat is a locking device that locks the seat into its folded position. The seat has hinges at the front edge and can be folded forward when the locking device is pushed.

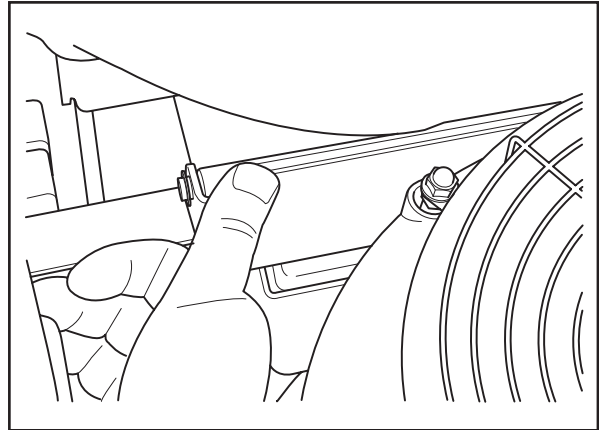

8011-440

The seat s locking device

## 9. Refueling

The machine has two fuel tanks, one on each side just behind the seat. The tanks take 5.7 gallons (22 liters) each.

The engine will run on a minimum of 87-octane unleaded gasoline (no oil mix). Environmentally adapted alkylate gasoline can be used beneficially. See also Technical Data concerning methanol and ethanol fuels.

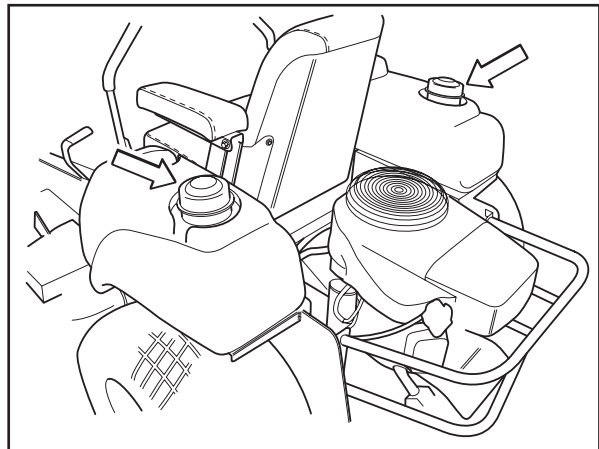

8011-524

Fuel tanks



### WARNING!

**Gasoline is highly flammable. Observe caution and fill the tank outdoors (see the safety rules).**



### WARNING!

**The engine and the exhaust system, become very hot during operation.**

**Risk for burns if touched.**

**Allow engine and exhaust system to cool at least two (2) minutes.**



### WARNING!

**Fill to bottom of filler neck. Do not overfill. Wipe off any spilled oil or fuel. Do not store, spill or use gasoline near an open flame.**

### IMPORTANT INFORMATION

**Experience indicates that alcohol blended fuels (called gasohol, ethanol or methanol) can attract moisture which leads to separation and formation of acids during storage. Acidic gas can damage the fuel system of an engine while in storage. To avoid engine problems, the fuel system should be emptied before storage of 30 days or longer. Drain the gas tank, start the engine and let it run until the fuel lines and carburetor are empty. Use fresh fuel the next season. See Storage Instructions for additional information. Never use engine or carburetor cleaners in the fuel tank or permanent damage may occur.**

When operating in temperatures below 32  F. (0  C.), use fresh, clean winter grade gasoline to help insure good cold weather starting.

# CONTROLS

## 10. Fuel Shut Off Valve

The fuel shut off valve is located at the right rear of the seat. The valve has three positions; right tank, left tank and center is the off position.

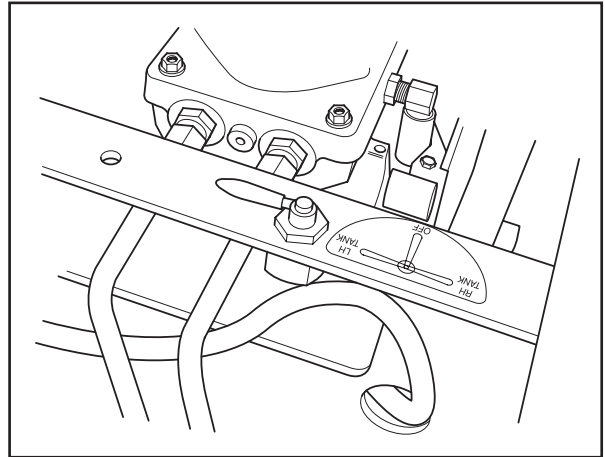

8011-506

*Fuel valve*

## 11. Seat Adjustment Lever

The seat can be adjusted lengthways. When making adjustments, the lever under the front edge of the seat is moved to the left (as seen by the driver in the seat), after which the seat can be moved backward or forward.

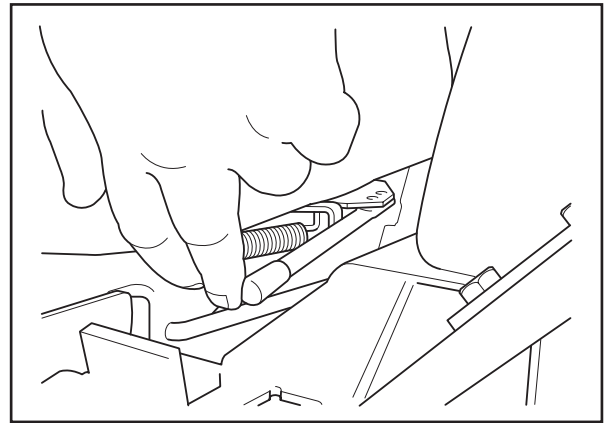

8011-441

*Lengthways adjustment*

## 12. Choke Control

The choke control is used for cold starts in order to provide the engine with a richer fuel mixture.

For cold starts the control should be pulled out.

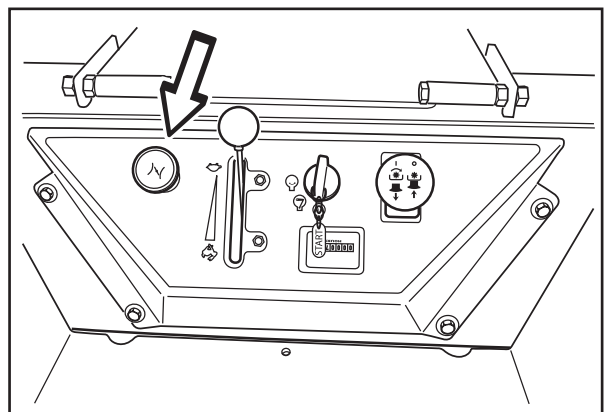

8011-508

*Choke control*

# CONTROLS

## 13. Throttle Control

The throttle control regulates the engine speed and thereby the rate of rotation of the blades, assuming the blade switch is pulled out, see Engaging the Mower Deck.

In order to increase or decrease the engine speed, the control is moved downward or upward respectively.

Avoid idling the engine for long periods, as there is a risk of fouling the spark plugs.

**USE FULL THROTTLE WHEN MOWING**, for best mower performance and battery charging.

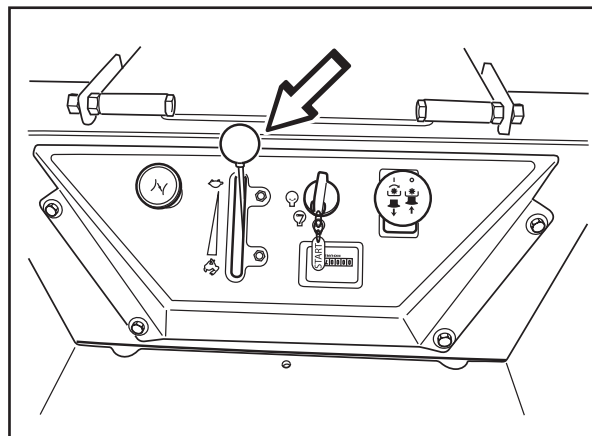

8011-509

*Throttle control*

## 14. Lifting Lever for the Mower Deck

The lifting lever is used to place the mower deck in the transport position or one of the 14 different cutting height positions.

The cutting height is set by placing a peg in the hole for the desired cutting height and the peg is then locked on the inside (hidden in the illustration) with the supplied pin.

1. Pull the lever backward to the locked position to engage the transport position. The deck is then raised.
2. Depress the lock handle, counter hold, and move the lifting lever forward toward the peg to engage the set cutting height. The deck is then lowered.
3. The lifting lever can also be used to temporarily adjust the cutting height, such as when passing a minor bump in the lawn.

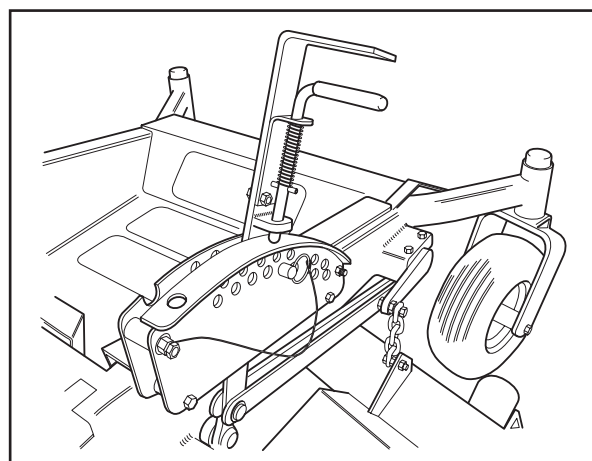

8011-525

*The mower deck's lifting lever*

### IMPORTANT INFORMATION

**In order to obtain an even cutting height it is important that the air pressure in all four tires is the same 15 psi (1 bar).**



# CONTROLS

## Cutting height pedal

On some models there is a deck assist lift pedal to aid in the lifting of the deck.

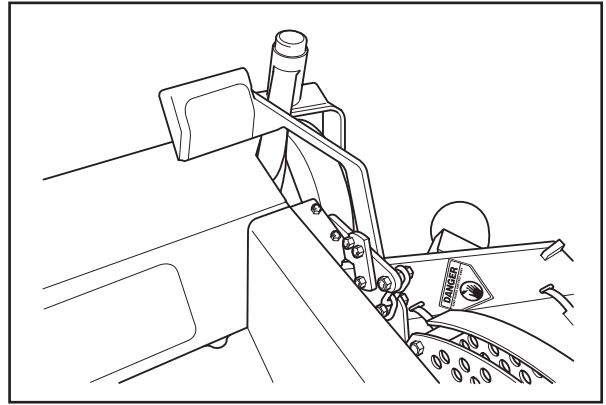

8011-465

*Cutting height pedal*

## Pump release valves

### IMPORTANT INFORMATION

Only rotate valve 1/4 - 1/2 turn to release system.

Tighten the valve moderately.

Do not overtighten the valve when closing. That can damage the valve seat.

Pump release valves are located at the pumps. They are used to release the system so the machine may be moved by hand when not running. Tilt seat forward to gain access to the pumps. Use a 5/8" wrench to open valve.

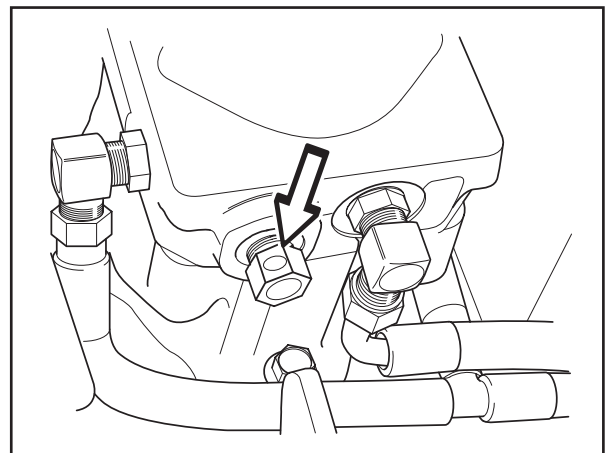

8011-507

*Pump release valve*

## Accessories

### Tunnel Deck Only

For mulching, there is a BioClip attachment available. This is mounted underneath the mower deck and consists of control plates and BioClip blades.

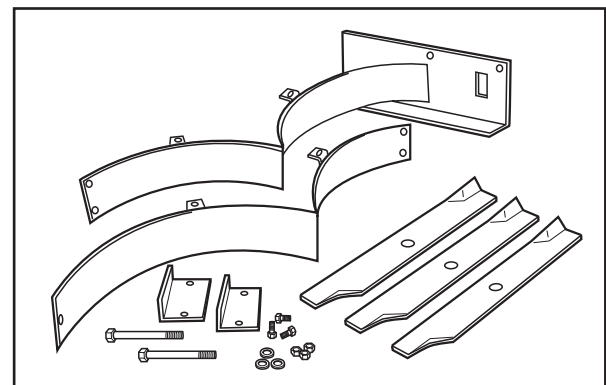

8011-566

*BioClip attachment*

---

# OPERATION

---

## Operation

Read "Safety Instructions" section and following pages, if you are unfamiliar with the machine.

## Training

Zero turn mowers are far more maneuverable than typical riding mowers due to their unique steering capabilities.

We suggest when first operating the mower, use a reduced throttle speed and reduced ground speed by NOT moving control levers to the furthest forward or reverse positions during initial operation, or until operator becomes comfortable with controls. We also suggest first time users, or new users to ZeroTurn mowers to become familiar with the mowers movement on a hard surface, such as concrete or blacktop PRIOR to attempting to operate on turf. Until operator becomes comfortable with mower controls and zero turning capability, they may damage turf due to over aggressive maneuvers.

### To move forward and backward

The direction and speed of the mowers movements is effected by the movement of the control lever(s) on each side of mower. The left control lever controls the left wheel motor. The right control lever controls the right wheel motor.

#### **IMPORTANT INFORMATION**

**When control levers are in the reverse position they return to neutral when released. This may cause the mower to suddenly stop.**

First time users should push mower (see "Moving by Hand" in the "Operation" section) to an open, flat area, without other people or vehicles/obstacles near by. In order to move unit under its own power, the operator must be in the seat, start engine (see "Before Starting" in the "Operation" section), adjust engine speed to idle, disengage park brake, do not engage blades at this time, rotate control levers inward. As long as the control levers have not been moved forward or backwards, mower will not move. Slowly move both control levers forward slightly, this will allow mower to start moving forward in a straight line. Pull back on control levers to the neutral position and mower should stop moving. Pull back slightly on control levers, this will allow mower to start moving backwards. Push forward on control levers to the neutral position and mower should stop moving.

### To turn to the right

While moving in a forward direction, pull the right lever back towards the neutral position while maintaining the position of the left lever, this will slow the rotation of the right wheel and cause the machine to turn in that direction.

### To turn to the left

While moving in a forward direction pull the left lever back towards the neutral position while maintaining the position of the right lever, this will slow the rotation of the left wheel and cause the machine to turn in that direction.

### To zero turn

While moving in a forward direction, first pull both control levers back until the mower stops or slows dramatically. Then by alternating one lever slightly to the forward position and the other in the reverse position.

# OPERATION

## Before Starting

- Read the sections "Safety Instructions" and "Controls" before starting the machine.
- Perform the daily maintenance before starting (see Maintenance Schedule in the Maintenance" section).
- Check that there is sufficient fuel in the fuel tanks.
- Adjust the seat to the desired position.

The following conditions must be fulfilled before the engine can be started:

- the driver must be seated on the seat,
- the blade switch for engaging the mower blades must be depressed,
- the parking brake must be on,
- both steering controls must be in the locked (outer) neutral position.

## Starting the Engine

1. Sit on the seat.
2. Raise the mower deck by pulling the lifting lever backward to the locked position (transport position).
3. Activate the parking brake.

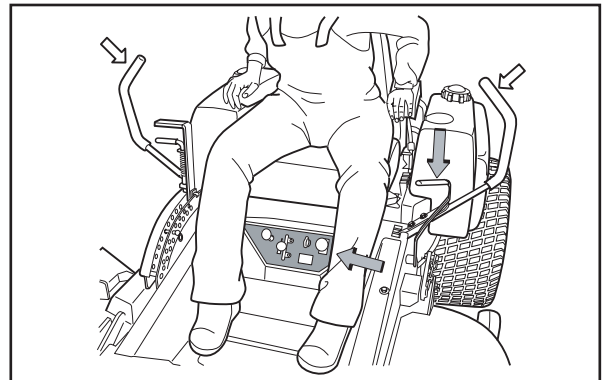

8011-527

*Start conditions*

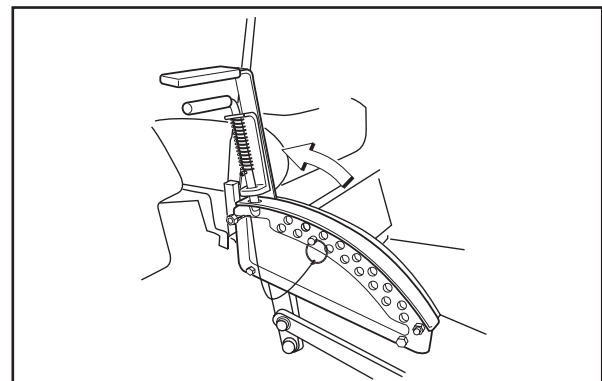

8011-552

*Raise the mower deck*

# OPERATION

4. Disengage the mower blades by depressing the blade switch.

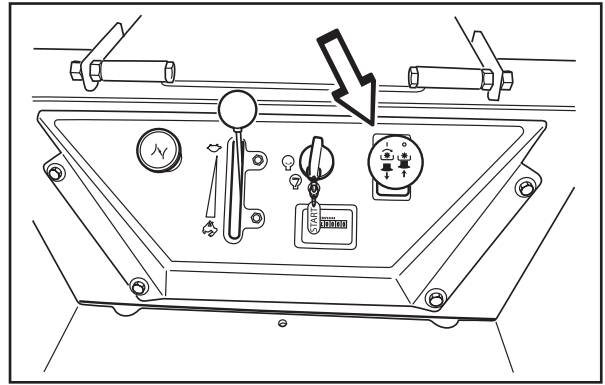

8011-510

*Depress the control for disengaging the mower deck*

5. Move the steering controls outward to the locked (outer) neutral position.

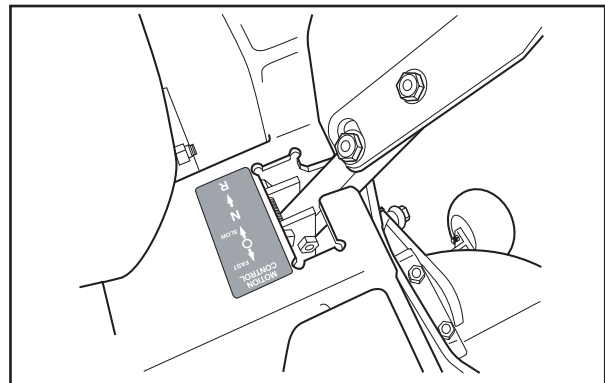

8011-526

*Steering controls in the outward, locked neutral position*

6. Move the throttle to the middle position.

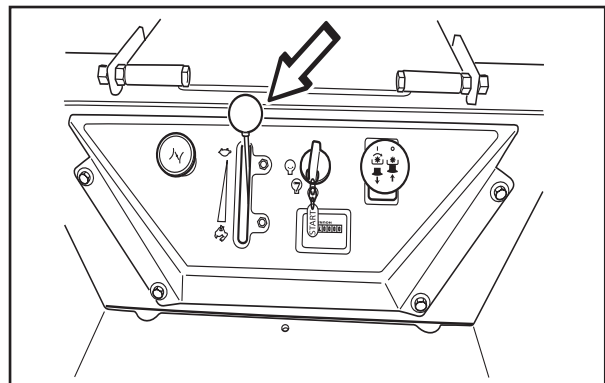

8011-509

*Set the throttle*

# OPERATION

7. If the engine is cold, the choke control should be pulled out to its extents.

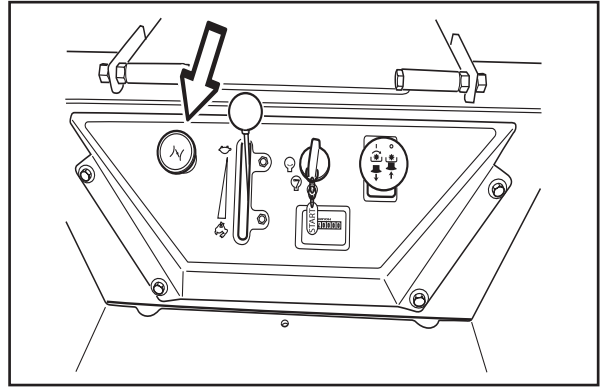

8011-508

*Set the choke control*

8. Open the fuel valve for the selected fuel tank.

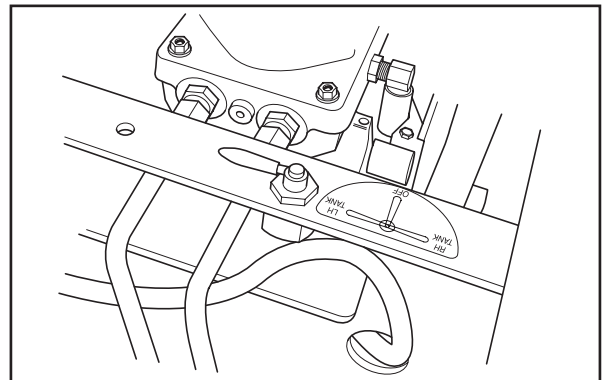

8011-506

*Open the fuel valve*

9. Press in and turn the ignition key to the start position.

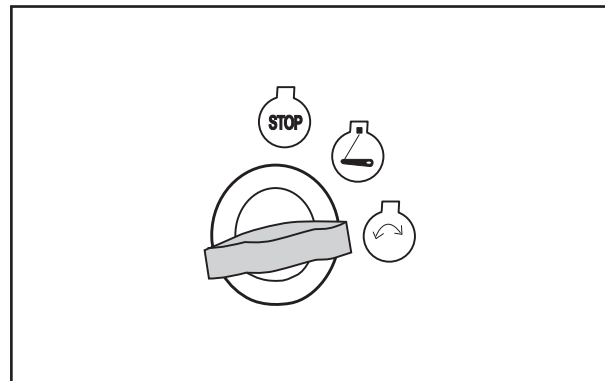

8011-742

*Turn to the start position*

# OPERATION

- When the engine starts, immediately release the ignition key back to the run position.

## IMPORTANT INFORMATION

**Do not run the starter for more than 5 seconds each time. If the engine does not start, wait about 10 seconds before re-trying.**

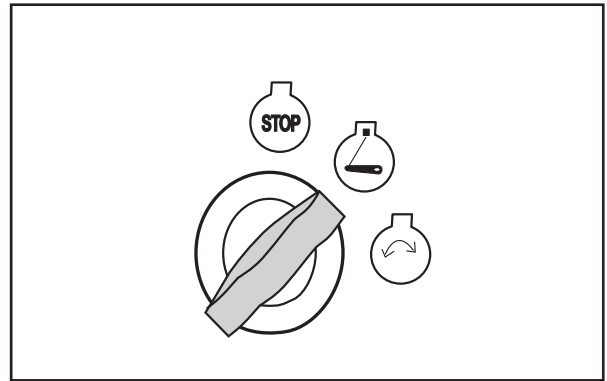

8011-743

*Return to run position*

- Press the choke control in gradually when the engine has started.

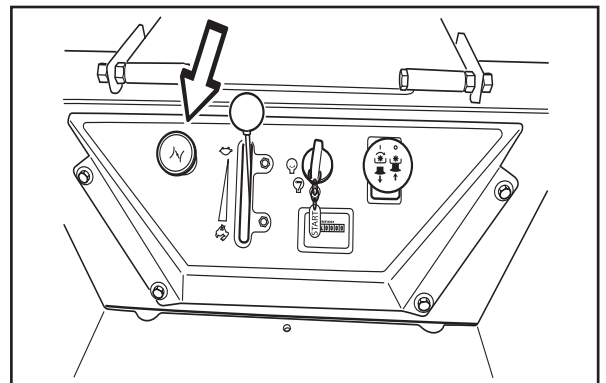

8011-508

*Gradually press in the choke control*

- Set the desired engine speed with the throttle.

Allow the engine to run at a moderate speed, "half throttle", for 3-5 minutes before loading it too heavily.

**USE FULL THROTTLE WHEN MOWING.**

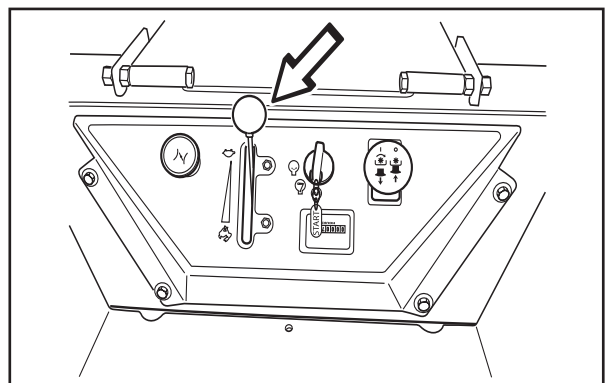

8011-509

*Set the engine speed*



## WARNING!

**Engine exhaust and certain vehicle components contain or emit chemicals considered to cause cancer, birth defects, or other reproductive system damage. The engine exhaust contains carbon monoxide, which is a odorless, colorless, poisonous gas. Do not use the machine in enclosed spaces.**

# OPERATION

## To start an engine with a weak battery



**WARNING!**  
Lead-acid batteries generate explosive gases. Keep sparks, flame and smoking materials away from batteries. Always wear eye protection when around batteries.

If your battery is too weak to start the engine, it should be recharged. (See "Battery" in the "Maintenance" section).

If "jumper cables" are used for emergency starting, follow this procedure:

### IMPORTANT INFORMATION

Your mower is equipped with a 12-volt negative grounded system. The other vehicle must also be a 12-volt negative grounded system. Do not use your mower battery to start other vehicles.

### To attach jumper cables

- Connect each end of the RED cable to the POSITIVE (+) terminal on each battery, taking care not to short against chassis.
- Connect one end of the BLACK cable to the NEGATIVE (-) terminal of the fully charged battery.
- Connect the other end of the BLACK cable to a good CHASSIS GROUND on the mower with the discharged battery, away from the fuel tank and battery.

### To remove cables, reverse order

- Remove BLACK cable first from chassis and then from the fully charged battery.
- Remove RED cable last from both batteries.

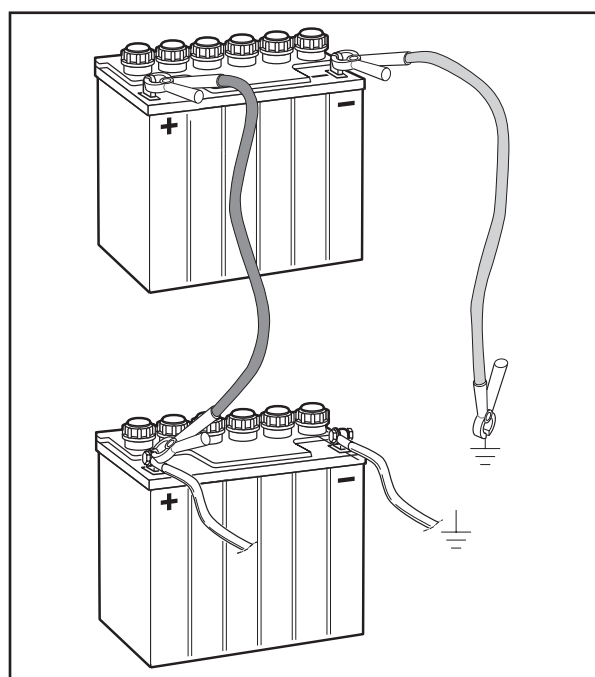

8011-642

*Jumper cables connection*

# OPERATION

## Running

1. Release the parking brake by moving the lever forward.

Your mower is equipped with an operator presence system. When the engine is running, any attempt by the operator to leave the seat without first setting the park brake will shut off the engine.

2. Move the steering controls to the neutral position (N).

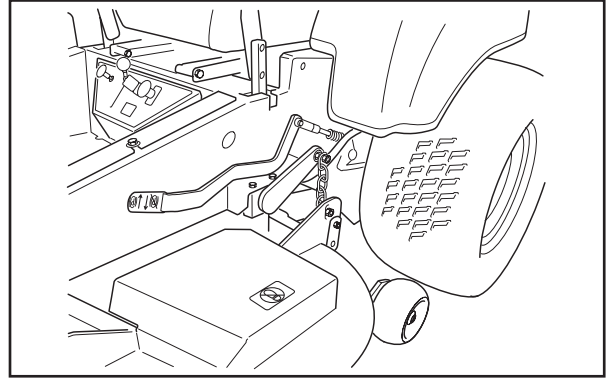

Released parking brake

3. Select the cutting height by placing the peg in one of the holes. Lock the peg on the inside with the pin.

4. Press in the stop handle, counter hold, and carefully move the lifting lever forward from the transport position toward the peg.

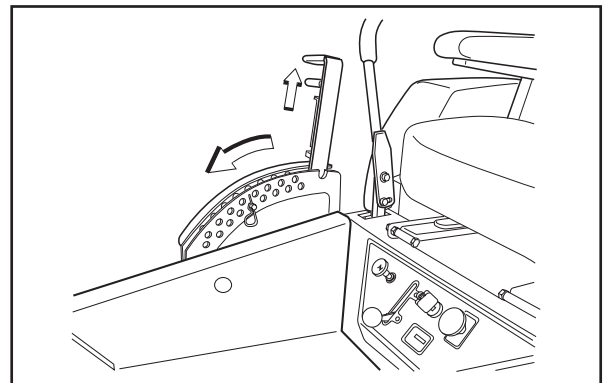

Cutting height selection

### IMPORTANT INFORMATION

The mower deck's anti-scalp rollers should be evenly adjusted.



### WARNING!

Ensure that no one is near the machine when engaging the Blade switch.

5. Engage the mower deck by pulling out the blade switch.
6. Move the throttle control to full throttle.
7. The machine's speed and direction are continuously variable using the two steering controls. When both controls are in the neutral position, the machine stands still.

By moving both controls an equal amount forward or backward, the machine moves in a straight line forward or backward respectively.

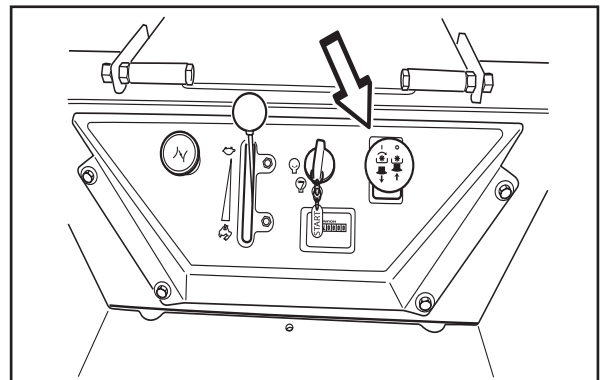

Engaging the mower deck



# OPERATION

In order, for example, to turn right while moving forward, move the right control towards the neutral position. The rotation of the right wheel is reduced and the machine turns to the right.

Turning on the spot can be achieved by moving one control backward (behind the neutral position) and carefully moving the other steering control forward from its neutral position.

## Operating on hills

Read the Safety Instructions "Driving on Slopes" in the "Safety Instructions" section.



### WARNING!

**Do not drive up or down hills with slopes greater than 10 degrees. And do not drive across any slopes.**

- The slowest speed possible should be used before starting up or down hills.
- Avoid stopping or changing speed on hills.
- If stopping is absolutely necessary, pull drive levers into the neutral position and push to the outside of the unit and engage the park brake.

### IMPORTANT INFORMATION

**Control levers return to neutral when released. This may cause the mower to suddenly stop.**

- To restart movement, release the park brake.
- Pull the control levers back to the center of the mower and press forward to regain forward motion.
- Make all turns slowly.

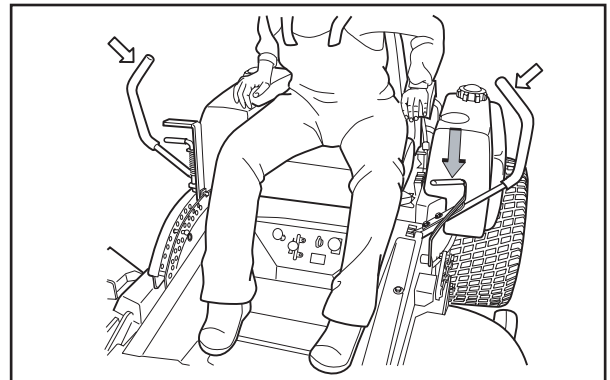

8011-640

*Stopping conditions*

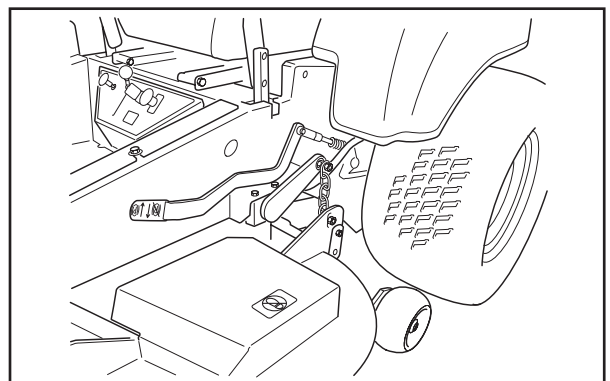

8011-511

*Released parking brake*

# OPERATION

## Mowing Tips

- Observe and flag rocks and other fixed objects to avoid collisions.
- Begin with a high cutting height and reduce it until the desired mowing result is attained.

The average lawn should be cut to 2 1/2" (64 mm) during the cool season and over 3" (76 mm) during the hot months. For healthier and better looking lawns, mow often after moderate growth.

For best cutting performance, grass over 6" (15 cm) in height should be mowed twice. Make the first cut relatively high; the second to the desired height.

- The mowing result will be best with a high engine speed (the blades rotate rapidly) and low speed (the rider moves slowly). If the grass is not too long and dense, the driving speed can be increased without negatively affecting the mowing result.
- The finest lawns are obtained by mowing often. The lawn becomes more even and the grass clippings more evenly distributed over the mown area. The total time taken is not increased as a higher operating speed can be used without poor mowing results.
- Avoid mowing wet lawns. The mowing result is poorer because the wheels sink into the soft lawn, clumps build, and the grass clippings fasten under the cowl.
- Hose the mower deck underside with water after each use. When cleaning, the mower deck shall be raised into the transport position. Make sure the mower is cooled and the engine is off.
- Use compressed air to clean top surface of the deck. Avoid flooding water on the top surface of the deck, engine, and electrical components.
- When the mulching kit is used, it is important that the mowing interval is frequent.

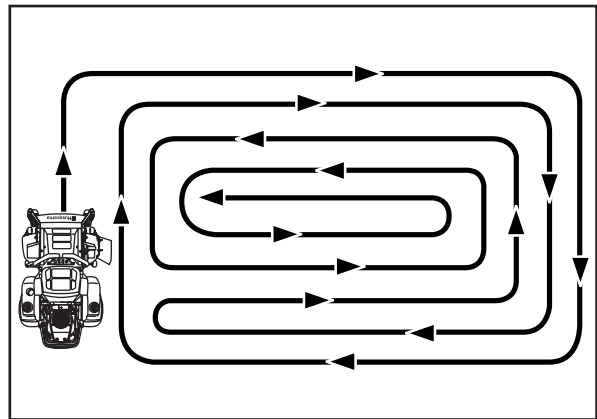
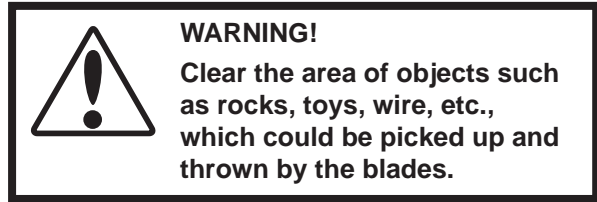

*Mowing patterns*

8011-603

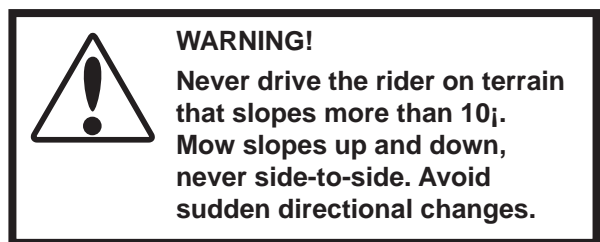

---

# OPERATION

---

## Stopping the Engine

Allow the engine to idle a minute in order to attain normal operating temperature before stopping it, if it has been worked hard. Avoid idling the engine for longer periods, as there is a risk of the spark plugs fouling.

1. Disengage the mower deck by depressing the blade switch.

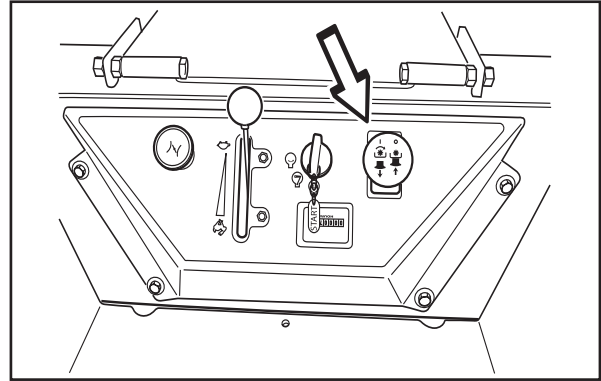

8011-510

*Disengage the mower deck*

2. Raise the mower deck by pulling the lifting lever backward to the transport position.
3. When the machine is standing still, activate the parking brake by pulling the lever backward.
4. Move the throttle to the minimum position (tortoise symbol). Turn the ignition key to the stop position. Never use choke to stop engine.
5. Move the steering controls outward.
6. Remove key. Always remove key when leaving the mower to prevent unauthorized use.

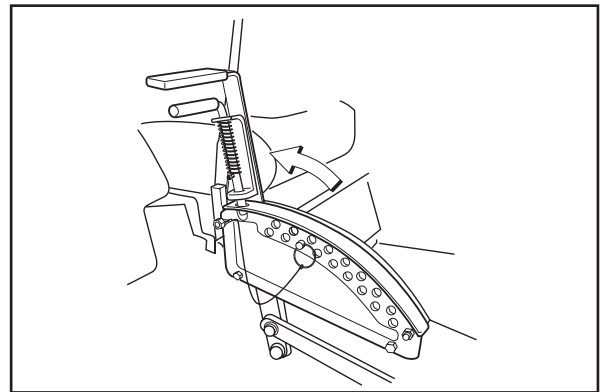

8011-552

*Raise the mower deck with the lifting lever*

### **IMPORTANT INFORMATION**

**Leaving the ignition switch in any other position than "OFF" will cause the battery to be discharged and the hour meter to accumulate hours.**

# OPERATION

## Moving by Hand

In order for the machine to be moved with the engine turned off, the pump release valves on both hydraulic pumps must be opened 1/4-1/2 turn.



### **WARNING!**

**No adjustments or maintenance to be carried out unless:**

- the engine stopped,
- the ignition key has been removed,
- the parking brake is on.

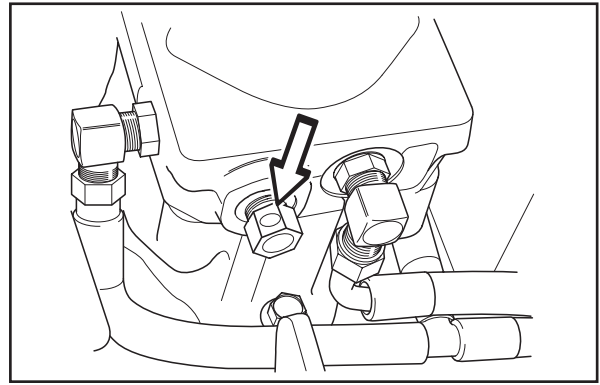

8011-507

*pump release valve on the hydraulic pump*

# MAINTENANCE

## Maintenance

### Maintenance Schedule

The following is a list of maintenance procedures that must be performed on the machine. For those points not described in this manual, visit an authorized service workshop. An annual service carried out by an authorized service workshop is recommended to maintain your machine in the best possible condition and to ensure safe operation.

Read Maintenance in the Safety Instructions section.

● = Described in this manual

○ = Not described in this manual

Maintenance	Page	Daily maintenance		Weekly maintenance	At least once each year	Maintenance interval in hours			
		Before	After			25	50	100	300
Check the parking brake	46	●							
Check the engine s oil level (every refueling)	54	●							
Check the hydraulic system s oil level	53	●							
Check the safety system	39	●							
Check for fuel and oil leakages	-	○							
Check/clean the engine s cooling air intake	41		●						
Check the mower deck	49		●						
Check hardware (screws, nuts, etc.)	51		●						
Clean under the mower deck	51		●						
Start the engine and blades, listen for unusual sounds	-		○						
Check for damage	-		○						
Thoroughly clean around the engine	-		○						
Thoroughly clean around the hydraulic system	-		○						
Clean around belts, belt pulleys, etc.	-		○						
Check the tire pressures	46					●			
Check battery	37					●			
Sharpen/Replace mower blades	47					●			
Check the fuel pump s air filter <sup>2)</sup>	45					●			
Clean the engine s cooling air intake <sup>2)</sup>	41				●	●			
Clean cyclon air filter dust cap	43				●	●			
Check/adjust the parking brake	-				○			○	
Inspect muffler/Spark arrester	-				○			○	

# MAINTENANCE

Maintenance	Page	Daily maintenance		Weekly maintenance	At least once each year	Maintenance interval in hours			
		Before	After			25	50	100	300
Check/adjust throttle and choke cables	41							●	
Check the condition of belts, belt pulleys, etc.	46				●			●	
Change the engine oil <sup>1)</sup>	54				●			●	
Replace the engine oil filter (every 200 hours)	59				●			●	
Clean/replace the spark plugs	38				●			●	
Replace the fuel filter	45				●			●	
Replace the air filter (main cartridge) <sup>2)</sup> (every 200 hours)	42				●			●	
Check the caster wheels (every 200 hours)	51							●	
Clean the cooling fins <sup>2)</sup>	-				○			○	
Replace the air cleaner s pre-filter <sup>2)</sup> (foam filter)	42				●				●
Check/adjust the mower deck	49				●				●
Change the hydraulic oil (every 300 hours)	-				○				○
Dismantle and inspect starter <sup>4)</sup> (every 500 h)									○
Replace the hydraulic oil filter (every 300 hours)	-				○				○
Check the engine valve clearance <sup>4)</sup>	-				○				○
Perform the 300-hour service <sup>4)</sup>	74				○				○
Lubricate according to Lubrication Schedule	52		●	●	●	●	●	●	●

<sup>1)</sup> First change after 8 hours. When operating with a heavy load or at high ambient temperatures, replace every 50 hours. <sup>2)</sup> In dusty conditions, cleaning and replacement are required more often. <sup>3)</sup> For daily use, the machine should be lubricated twice weekly. <sup>4)</sup> Performed by authorized service workshop.

● = Described in this manual

○ = Not described in this manual



**WARNING!**

**No adjustments or maintenance to be carried out unless:**

- ✘ The engine is stopped.
- ✘ The ignition key has been removed.
- ✘ The parking brake is on.

# MAINTENANCE

## Battery

Your mower is equipped with a maintenance free battery and does not need servicing. However, periodic charging of the battery with an automotive type battery charger will extend its life.

- ¥ Keep battery and terminals clean.
- ¥ Keep battery bolts tight.
- ¥ Recharge at 6-10 amperes for 1 hour

### To clean battery and terminals

Corrosion and dirt on the battery and terminals can cause the battery to leak power.

1. Lift seat and rotate forward.
2. Remove the red terminal guard.
3. Disconnect BLACK battery cable first, then the RED battery cable and remove the battery from the machine.
4. Rinse the battery with plain water and dry.
5. Clean terminals and battery cable ends with wire brush until shiny.
6. Coat terminals with grease or petroleum jelly
7. Reinstall battery.

### Replacing battery

1. Lift Seat and rotate forward.
2. Remove the terminal guard.
3. Using two 1/2" wrenches disconnect BLACK battery cable then RED battery cable.
4. Unscrew the knob and remove battery hold down.
5. Carefully remove the battery from the mower.
6. Install new battery with terminals in the same position as the old battery.
7. Reinstall battery hold down.
8. First connect RED battery cable to positive (+) battery terminal with hex bolt and hex nut.



**Always use protective glasses when handling the battery.**

### IMPORTANT INFORMATION

**Do not attempt to open or remove caps or covers. Adding or checking level of electrolyte is not necessary.**

**Always use two wrenches for the terminal screws**



### WARNING!

**Do not short battery terminals by allowing a wrench or any other object to contact both terminals at the same time. Before connecting battery, remove metal bracelets, wristwatch bands, rings, etc.**

**Positive terminal must be connected first to prevent sparks from accidental grounding.**

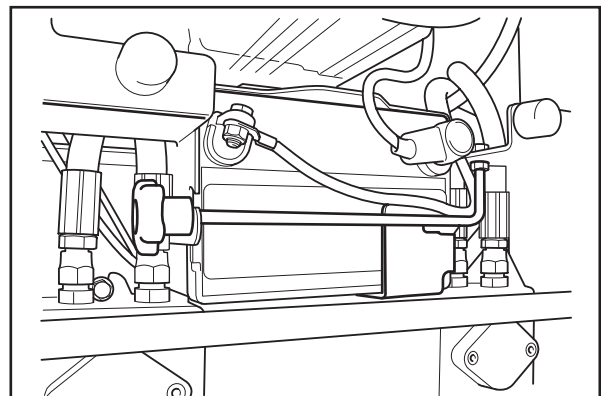

*Battery installation*

8011-445

# MAINTENANCE

9. Connect BLACK grounding cable to negative (-) battery terminal with remaining hex bolt and hex nut.
10. Fit the terminal guard.
11. Lower seat.

## Ignition System

The engine is equipped with an electronic ignition system. Only the spark plugs require maintenance.

For recommended spark plugs, see Technical Data.

1. Remove the ignition cable boot and clean around the spark plug.
2. Remove the spark plug with a spark plug socket wrench.
3. Check the spark plug. Replace the spark plug if fouled, the electrodes are burned and if the insulation is cracked or damaged. Clean the spark plug with a steel brush if it is to be reused.
4. Measure the electrode gap with a gapping tool. The gap should be .030 (0.75 mm). Adjust as necessary by bending the side electrode.
5. Reinsert the spark plug, turning by hand to avoid damaging the threads.
6. After the spark plug is seated, tighten it using a spark plug wrench so that the washer is compressed. A used spark plug should be turned 1/8 of a turn from the seated position. A new spark plug should be turned 1/4 a turn from the seated position.
7. Replace the ignition cable.

### IMPORTANT INFORMATION

**Fitting the wrong spark plug type can damage the engine.**

**Inadequately tightened spark plugs can cause overheating and damage the engine. Tightening the spark plugs too hard can damage the threads in the cylinder head.**

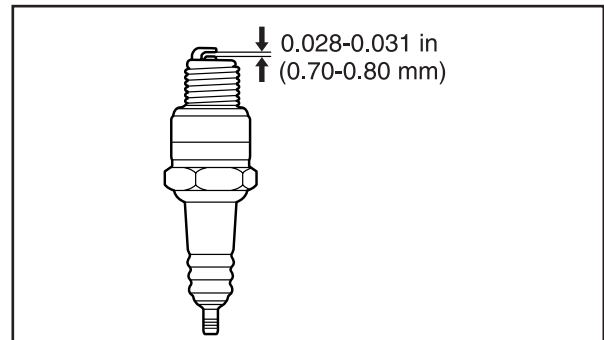

8011-05

*Measure the electrode gap*



# MAINTENANCE

## Checking the Safety System

The machine is equipped with a safety system that prevents starting or driving under the following conditions.

The engine can only be started when:

1. The mower deck is disengaged.
2. The steering controls are in the outer, locked neutral position.
3. The driver is sitting in the driver's seat.
4. The parking brake is on.

Make daily inspections to ensure that the safety system works by attempting to start the engine when one of the conditions is not met. Change the conditions and try again.

If the machine starts when one of these conditions is not met, turn the machine off and repair the safety system before using the machine again.

Make sure the engine stops when the park brake is not engaged and the operator leaves the seated position.

Check that the engine stops if the mower blades are engaged and the driver temporarily stands up.

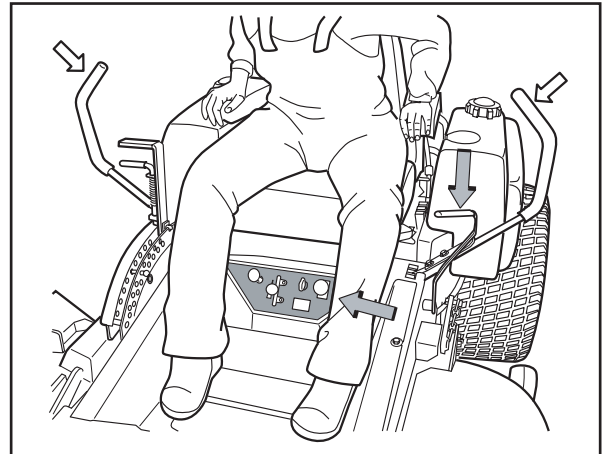

8011-527

*Conditions for starting*

### **IMPORTANT INFORMATION**

**In order to drive the unit, the driver must sit in the seat and release the parking brake before the steering controls can be moved into the neutral position, otherwise the engine will stop.**

# MAINTENANCE

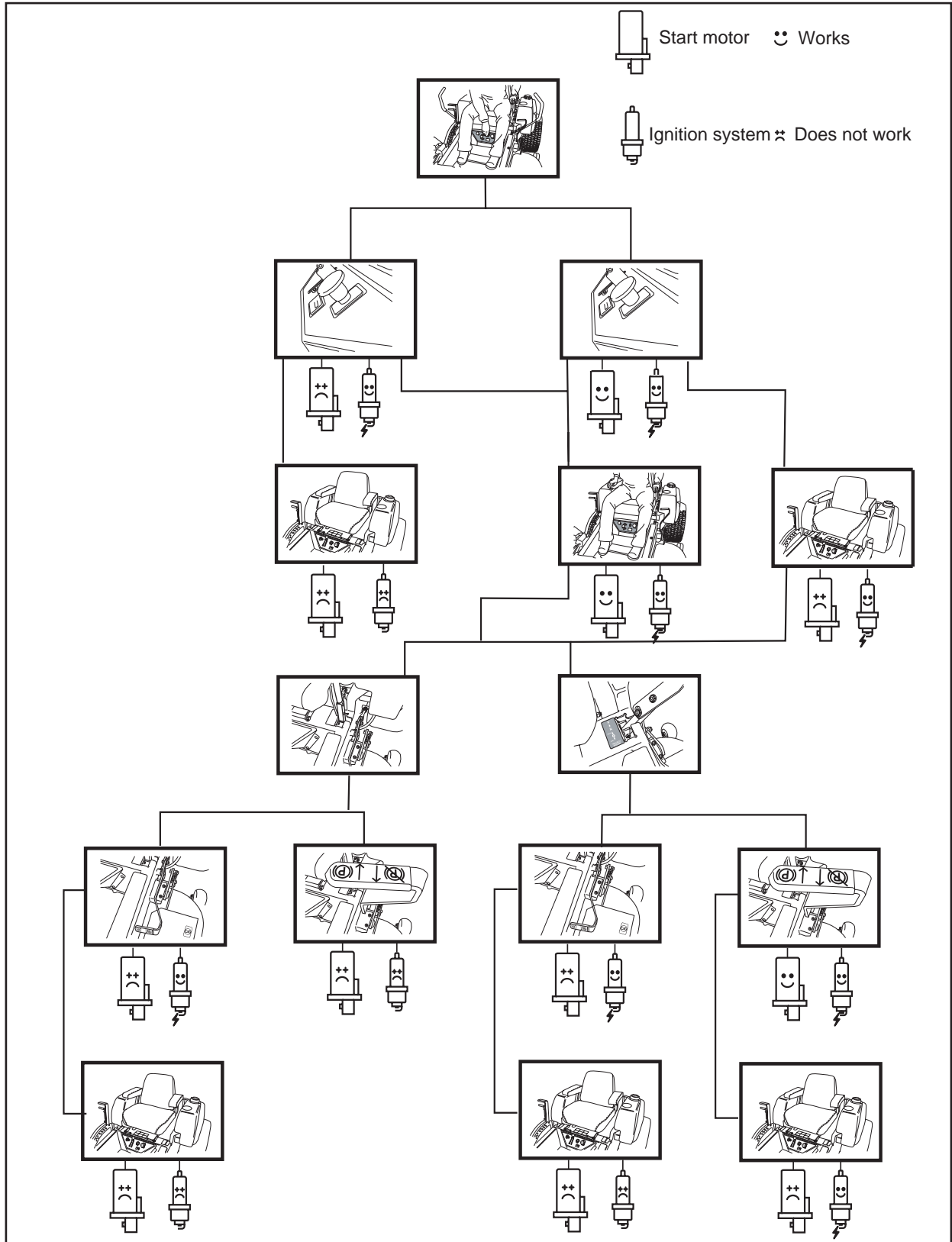

Safety system

8011-553

# MAINTENANCE

## Checking the Engine's Cooling Air Intake

Check that the engine's cooling air intake is free from leaves, grass, and dirt.

If the cooling air intake is clogged, engine cooling deteriorates, which can lead to engine damage.

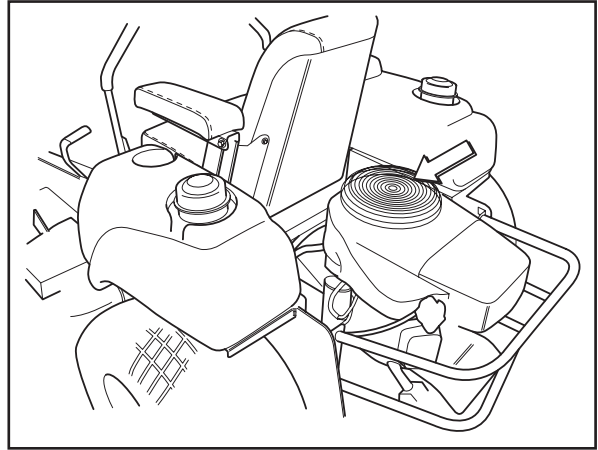

8011-625

*Check and clean the cooling air intake*

## Checking and Adjusting the Throttle Cable

Check that the engine responds to throttle increases and that a good engine speed is attained at full throttle.

If doubts arise, contact the service workshop. If adjustments are necessary, they can be made as follows for the lower cable:

1. Loosen the clamping screw for the cable's outer casing and move the throttle to the full throttle position.
2. Check that the throttle cable is mounted in the correct hole in the lower lever, see illustration.
3. Push the throttle cable's outer casing as far to the left as possible and tighten the clamping screw.

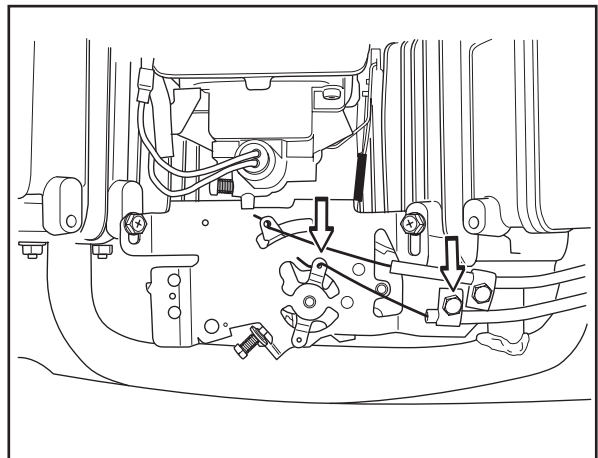

8011-554

*Adjusting the throttle cable*

## Checking and Adjusting the Choke Cable

If the engine produces black smoke or is difficult to start, this can be because the choke cable is incorrectly adjusted (upper cable). If doubts arise, contact the service workshop. If adjustments are necessary, they can be made as follows:

1. Loosen the clamping screw for the cable's outer casing and move the choke lever to the full choke position.
2. Check that the choke cable is mounted in the upper lever, see illustration. Push the choke cable's outer casing as far to the right as possible and tighten the clamping screw.

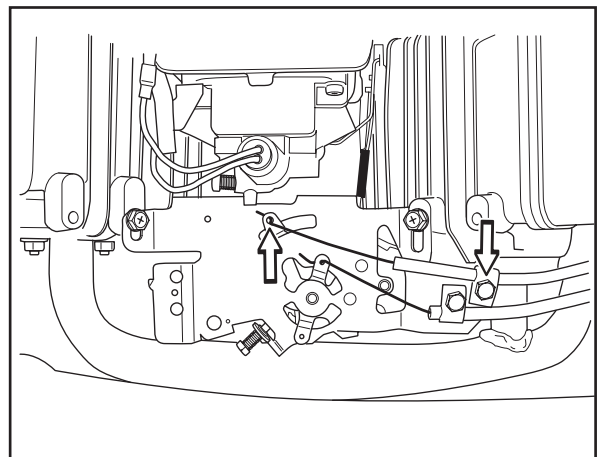

8011-555

*Adjusting the choke cable*

# MAINTENANCE

## Replacing the Air Filter

### Standard air filter

If the engine seems weak or runs unevenly, the air filter may be clogged. If run with a dirty air filter, the spark plugs can become fouled, disrupting operation.

For this reason, it is important to replace the air filter regularly (see the heading Maintenance Schedule for the proper service interval).

Cleaning/replacing the air filter is carried out as follows:



#### **WARNING!**

**The engine and the exhaust system become very hot during operation.**

**Risk for burns if touched.**

**Allow engine and exhaust system to cool at least two (2) minutes.**

1. Remove the plastic fastener on the top of the air filter cowling and remove the air filter cowling.
2. Remove the foam rubber pre-filter and clean using a mild detergent.  
Squeeze it dry with a clean cloth.
3. Remove the wing nuts for the air filter and remove the paper filter. Tap the paper filter against a fixed surface to remove dust. If the paper filter is still dirty, it must be replaced.

#### **IMPORTANT INFORMATION**

**Do not use compressed air to clean the air filter.**

**Do not wash the paper filter.**

**Do not oil the paper filter.**

4. Refit the air filter as follows:  
Check that the seal on the bottom of the paper filter is whole.  
Mount the paper filter in the air filter housing and tighten the wing nuts.
5. Refit the pre-filter on the paper filter.
6. Replace the cowling over the air filter housing. Do not over tighten the plastic fastener.

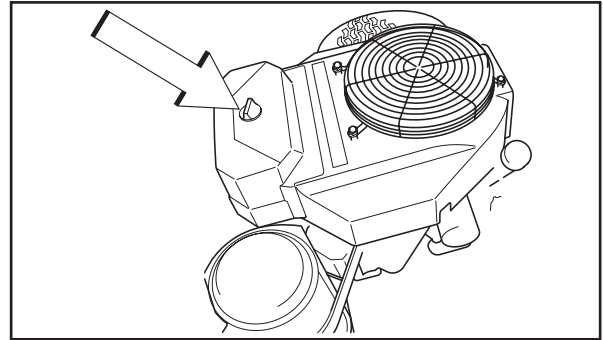

8011-768

*Remove the air filter cowling*

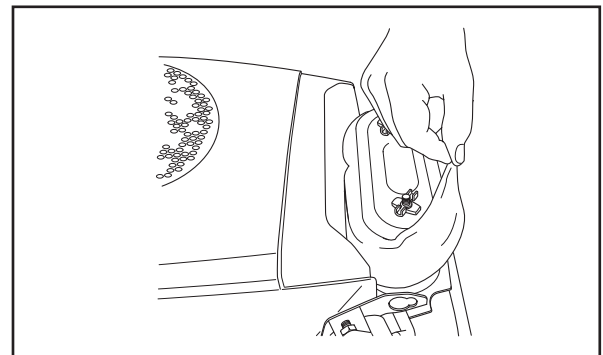

8011-557

*Remove the pre-filter*

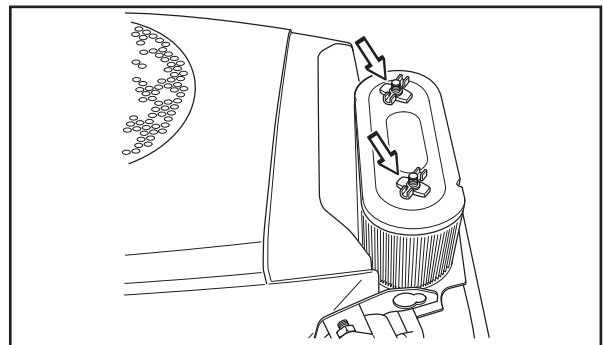

8011-558

*Remove the paper filter*

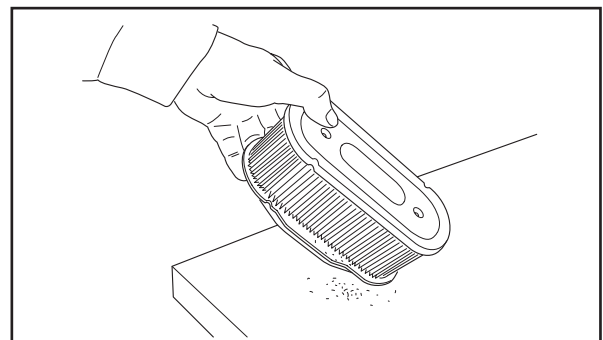

8009-181

*Remove dust*

# MAINTENANCE

## Cyclon air filter maintenance

If the engine seems weak or runs unevenly, the air filter may be clogged. If running with a soiled air filter, the spark plugs can obtain a coating that disrupts operation.

For this reason, it is important to replace the air filter regularly (see the heading Maintenance Schedule for the proper service interval).



### WARNING!

The engine and the exhaust system become very hot during operation.

Risk for burns if touched.

Allow engine and exhaust system to cool at least two (2) minutes before refueling

Cleaning/replacing the air filter is carried out as follows:

### IMPORTANT INFORMATION

Do not use compressed air to clean the air filter.

Do not wash the paper filter.

Do not oil the paper filter.

### Dust cap

Check the dust cap every day by pressing the rubber valve with two fingers to let out the dirt.

### IMPORTANT INFORMATION

The end cover must be installed with the rubber valve pointing downwards, otherwise the rubber valve will not function.

Clean the dust cap by removing the end cover of the air cleaner and clean the inside.

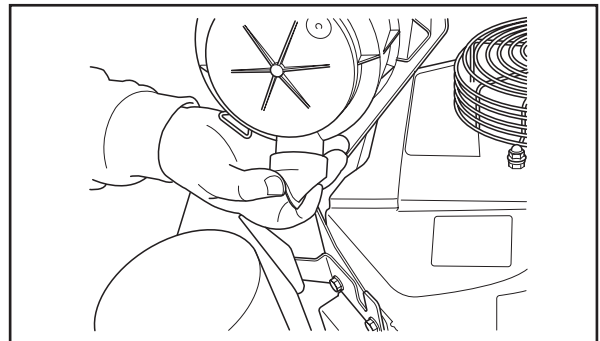

8011-447

Pressing the rubber valve

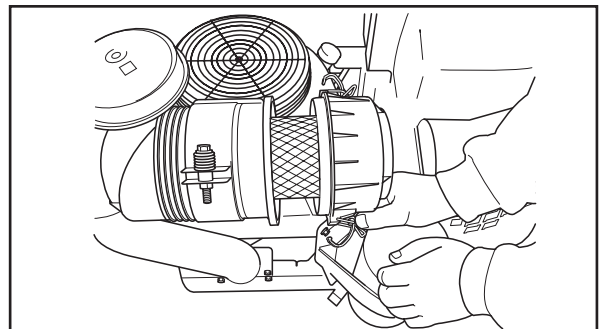

8011-448

Removing the end cover

# MAINTENANCE

## Filter replacement

1. Remove the end cover.
2. Remove the main filter (outer filter) by pulling it out by hand.

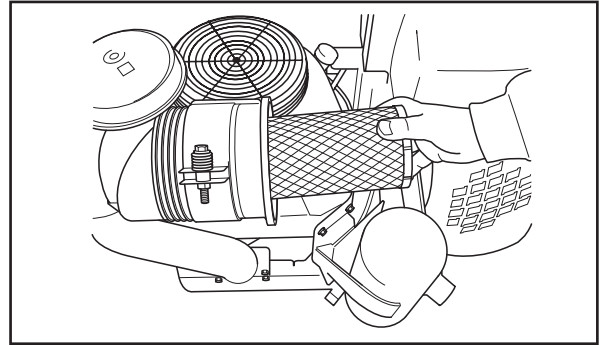

8011-449

*Removing the main filter*

3. Remove the inner filter by pulling it out by hand.
4. Clean inside of the filter housing. Wipe dry only.
5. Install the inner filter with the open end first. Ensure that it enters its recess at the end of the housing by pushing it in to the stop.
6. Install the main filter with the open end first. Ensure that it enters its recess at the end of the housing by pushing it in to the stop.

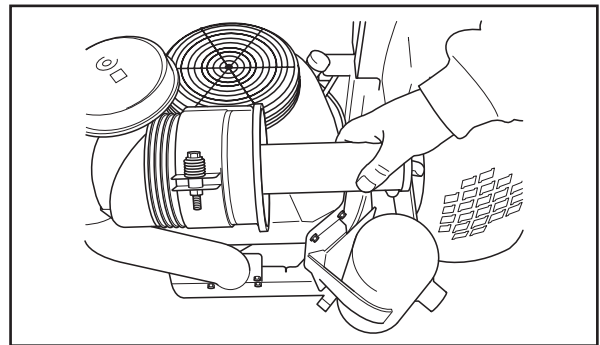

8011-450

*Removing the inner filter*

### IMPORTANT INFORMATION

**The end cover must be installed with the rubber valve pointing downwards, otherwise the rubber valve will not function.**

7. Turn the end cover with the rubber valve pointing downwards and install it.

## Air filter indicator (optional)

Change the main filter when the yellow piston is hanging at the top of the cylinder. To reset the indicator, push on the button (arrow) at the cylinder. A number of pushes may be required. If it indicates soon after a main filter replacement, change the inner filter.

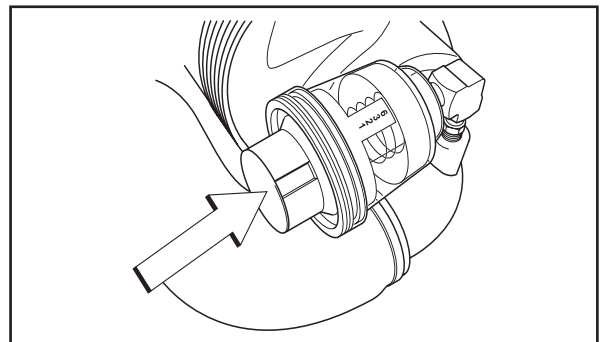

8011-467

*Air filter indicator*

# MAINTENANCE

## Replacing the Fuel Filter

Replace the line-mounted fuel filter every 100 hours (once per season) or more often if it becomes clogged.

Replace the filter as follows:

1. Move the hose clamps away from the filter. Use flat-nosed pliers.
2. Pull the filter loose from the hose ends.
3. Push the new filter into the hose ends. Position the filter with the FLOW arrow pointing up toward the fuel pump. If necessary, a soap solution can be applied to the filter ends to ease mounting.
4. Move the hose clamps back toward the filter.

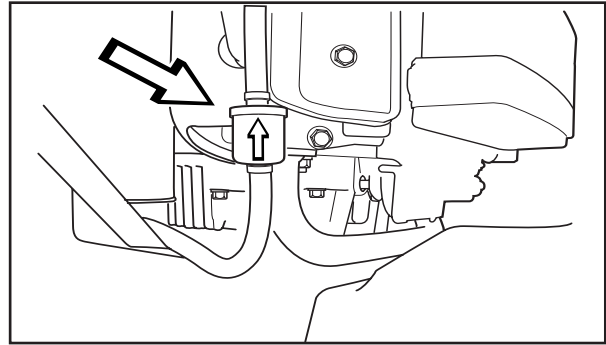

8009-146

*Fuel filter Kawasaki*

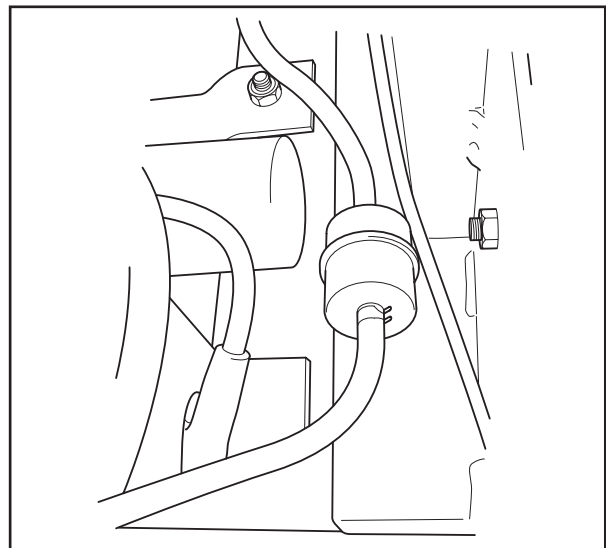

8011-468

*Fuel filter Kohler*

## Checking the Fuel Pump's Air Filter

Regularly check that the fuel pump's air filter is free from dirt.

Remove the screws and open the pump, no hoses need be removed.

The filter can be cleaned with a brush if necessary.

Replace the filter on the console.

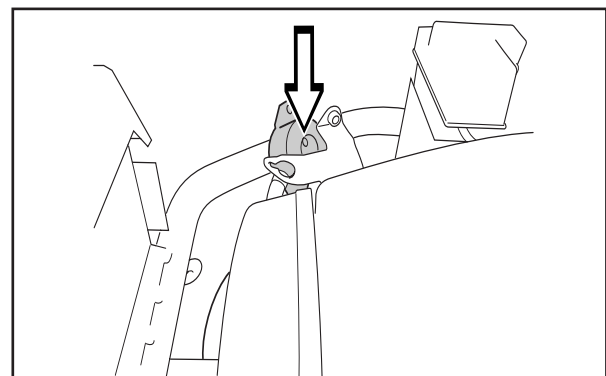

8009-147

*The fuel pump's air filter*



# MAINTENANCE

## Checking Tire Pressures

All four tires should have a pressure of 15 psi / 103 kPa / 1 bar.

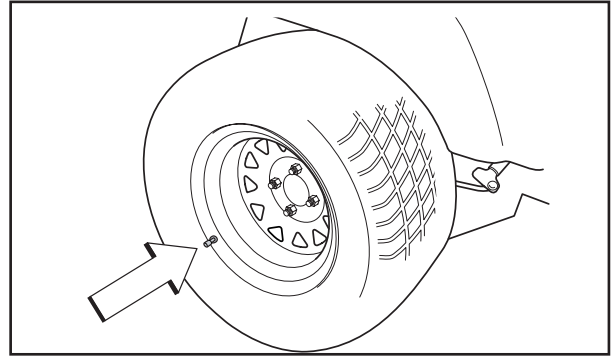

8011-564

Tire pressures

## Checking the Parking Brake

Visually check that no damage is found on the lever, links, or switch belonging to the parking brake. Perform a test drive and check that there is sufficient braking action.

To adjust the parking brake, contact the Husqvarna service workshop.

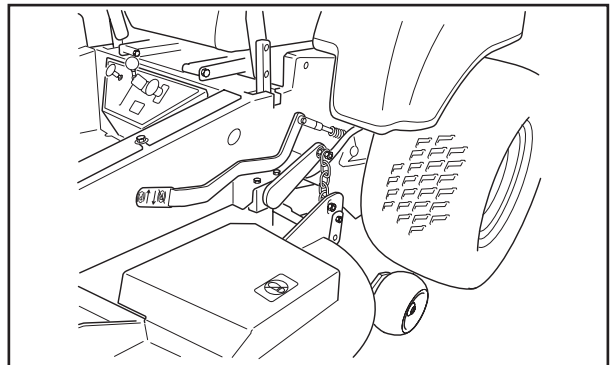

8011-511

The parking brake in the disengaged position



### WARNING!

Faulty adjustment can cause an accident.

## Checking the V-belts

### Deck belt

Check every 100 hours of operation. Check for severe cracking and large nicks.

NOTE: The belt will show some small cracks in normal operation.

To replace belt, lower the deck to its lowest position. Remove the foot plate and belt shields.

Use a ratchet with a 9/16" socket on the spring idler bolt to relieve the tension on the belt. Slide the belt off the pulley and remove the belt.

Reverse the procedure for installation. See the decal on the top of deck for belt routing information.

After installation is complete check the belt for twists.

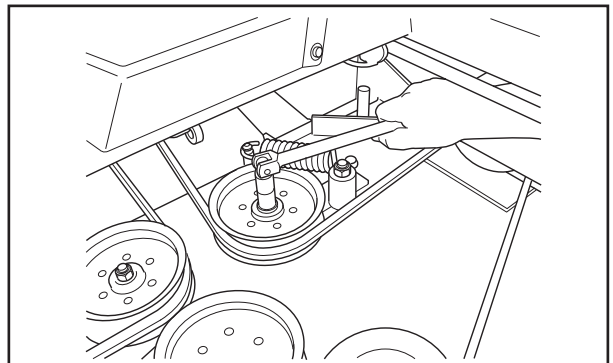

8011-622

Slackening the belt tensioner

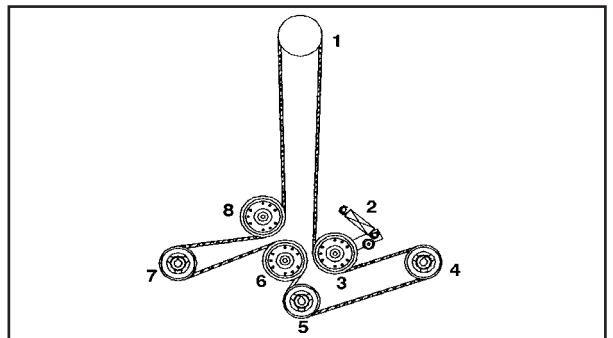

8011-580

Belt routing, deck belt



# MAINTENANCE

## Pump belt

Check belt every 100 hours for excessive wear.

To replace belt. Relieve tension on the deck belt and remove deck belt from clutch. See Deck belt in Maintenance section. Loosen bolt on the clutch tie down and rotate out of the way.

Using a 1/2" drive ratchet inserted into the square hole in the pump idler arm, relieve the tension on the pump belt and remove belt.

To reinstall belt. Swing pump idler pulley out toward engine to route belt around it. Then route belt around the pulley for the left pump first (right hand pulley in the illustration).

Reinstall idler spring and use the ratchet to rotate idler so the belt may be installed all the way around the last pulley.

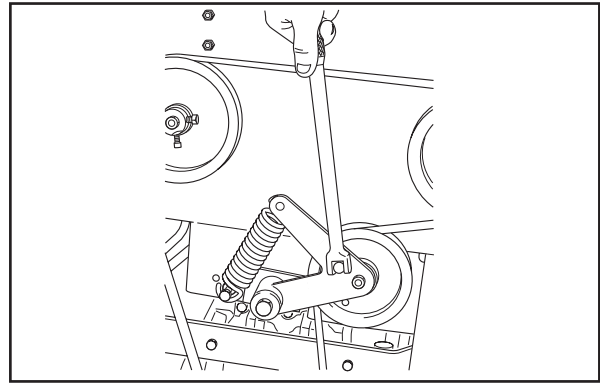

8011-623

*Slackening the belt tension*

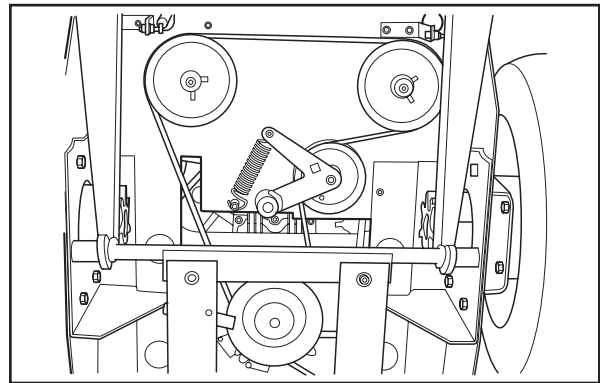

8011-624

*Belt routing, hydraulic pumps*

## Checking the Blades

In order to attain the best mowing performance, it is important that the blades are well sharpened and not damaged.

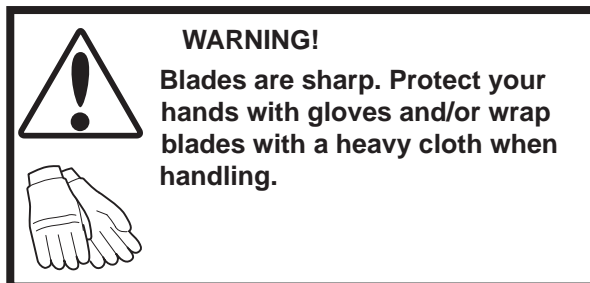

Bent or cracked blades or blades with large nicks should be replaced.

Check the blade mounts.

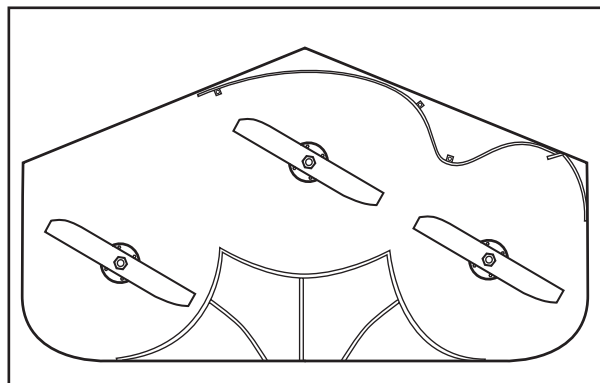

8011-604

*Check the blades*

### IMPORTANT INFORMATION

**The sharpening of blades should be carried out by an authorized service workshop.**

Damaged blades should be replaced when hitting obstacles that result in a breakdown. Let the service workshop decide whether the blade can be repaired/ground or must be discarded.

# MAINTENANCE

## Blade replacement:

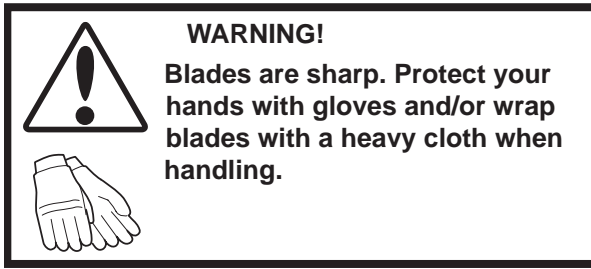

- ¥ Remove blade bolt by turning counterclockwise.
- ¥ Install new or re-sharpened blade with stamped "GRASS SIDE" facing towards ground/grass (down) or THIS SIDE UP facing deck and cutter housing.  
Some blades may not be stamped with GRASS SIDE and THIS SIDE UP . These blades can be installed either way.
- ¥ Install and tighten blade bolt securely.  
Tunnel Deck - Torque blade bolt to 90 ft/lbs (122 Nm).  
Combi Deck - Torque blade bolt to 57-61 ft/lbs (77-82 Nm).

### IMPORTANT INFORMATION

Special blade bolt is heat treated.  
Replace with a Husqvarna bolt if required.  
Do not use lower grade hardware than specified.

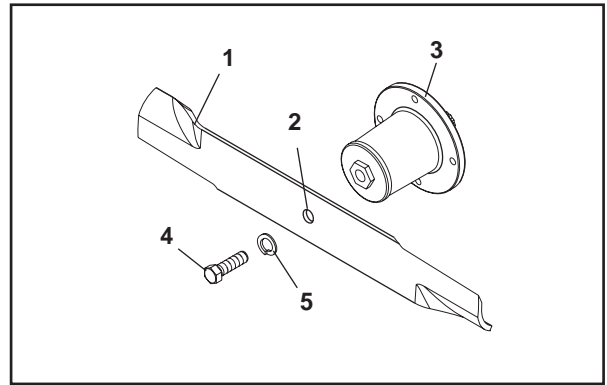

1. Blade
2. Center hole
3. Cutter housing
4. Blade bolt
5. Lockwasher

### Blade attachment

# MAINTENANCE

## Adjusting the Mower Deck



### WARNING!

Before performing any service or adjustment checklist:

1. Engage the parking brake.
2. Place the blade-switch in the disengaged position.
3. Turn ignition switch to OFF position and remove the key.
4. Make sure the blades and all moving parts have completely stopped.
5. Disconnect the spark plug wire from all spark plugs and place the wire where it cannot come in contact with the plug.

### Leveling

1. Position the mower on a level, preferably concrete, surface.
2. Check the pressure in all four tires. See Technical Data .
3. Raise the mower on lengths of 2" x 4" placed edgewise under the cutting deck from front to rear (see diagram).
4. Lower the deck onto the 2 x 4 «s. The rear of the deck is approximately 1/4 deeper than the front. This gives the deck a proper pitch front to back when lowered onto the 2 x 4 guides.
5. Set cutting height to 4 .
6. Adjust the four lower chain bolts so that they are centered in the oblong slots.
7. Move the lifting lever and check that all the chains are equally tensioned. If they are not, adjust the appropriate lower chain bolt in its slot.



### WARNING!

Blades are sharp. Protect your hands with gloves and/or wrap blades with a heavy cloth when handling.

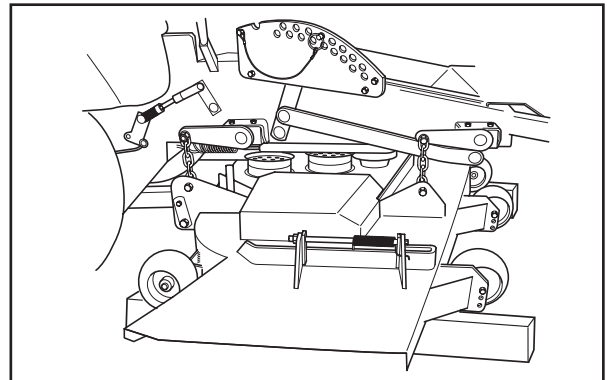

8011-601

Leveling the mower deck

### Adjusting Cutting Height

1. Raise and secure the deck height lever to the transport position (Tunnel Deck - 5 (127mm), Combi Deck 4 3/4 (120.7mm).
2. Position blade tip so it is straight forward.
3. Measure from the cutting edge of the blades to a flat level surface. The distance should be (Tunnel Deck - 5" (127 mm), Combi Deck - 4 3/4 (120.7mm).
4. Drop and secure the lever at (for example) the 2" cutting height. Measure as above. The distance should be 2" (50 mm).

# MAINTENANCE

## To adjust anti-scalp rollers

Anti-scalp rollers are properly adjusted when they are just slightly off of the ground when the deck is at the desired cutting height in the operating position. Anti-scalp rollers then keep the deck in the proper position to help prevent scalping in most terrain conditions.

### IMPORTANT INFORMATION

**Adjust Anti-scalp rollers with the mower on a flat level surface.**

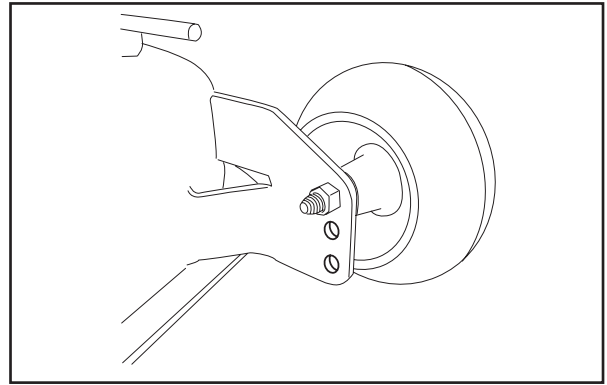

CZ-9

*Anti-scalp roller - Tunnel Decks*

### Tunnel Deck -

The anti-scalp rollers can be set in three positions.

- ¥ Upper position 1.5 to 3 (38 to 76 mm) grass.
- ¥ Middle position 3 to 4.5 (76 to 114 mm) grass.
- ¥ Lower position 4.5 to 6 (114 to 152 mm) grass.

### Combi Deck -

The anti-scalp rollers can be set in two positions.

- ¥ Upper position 1.5 to 3 (38 to 76mm) grass.
- ¥ Lower position 3 to 5 (38 to 127mm) grass.

The rollers should be approximately 1/4 (6.5 mm) from ground.

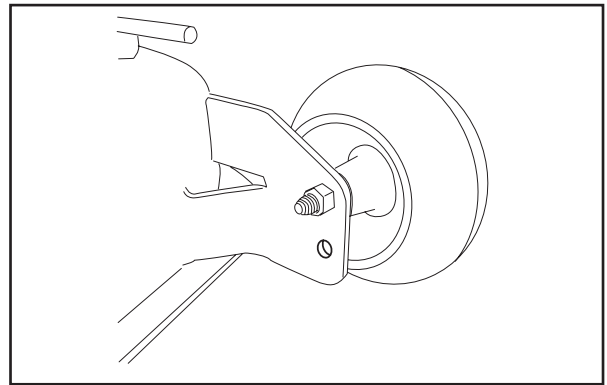

CZ-9

*Anti-scalp roller - Combi Decks*

### IMPORTANT INFORMATION

**The anti-scalp rollers must not be used for gauge wheels or the roller and deck may be damaged.**

# MAINTENANCE

## Cleaning and Washing

Regular cleaning and washing, especially under the mower deck, will increase the machine's lifespan. Make it a habit to clean the machine directly after use (after it is cooled), before the dirt sticks.

Do not spray water on the top of the mower deck. Use compressed air to clean the top side of mower deck. Regularly clean deck and underside of deck, avoid spraying engine and electrical components with water.



**Use protective glasses when cleaning and washing.**

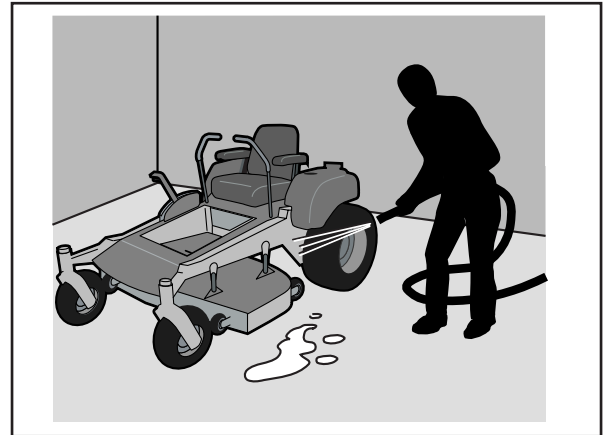

8011-644

*Cleaning*

## Caster Wheels

Check every 200 hours. Lift front of unit off of ground so caster wheels can rotate freely. Tighten caster bolt (34) then back off 1/2 turn. Check that wheel rotates freely. If wheel does not rotate freely back the caster bolt off in 1/4 turn increments until wheel rotates freely.

### IMPORTANT INFORMATION

**DO NOT add any type of tire liner or foam fill material to the tires. Excessive loads created by foam filled tires will cause premature failures.**

**Only use O.E.M. specified tires.**

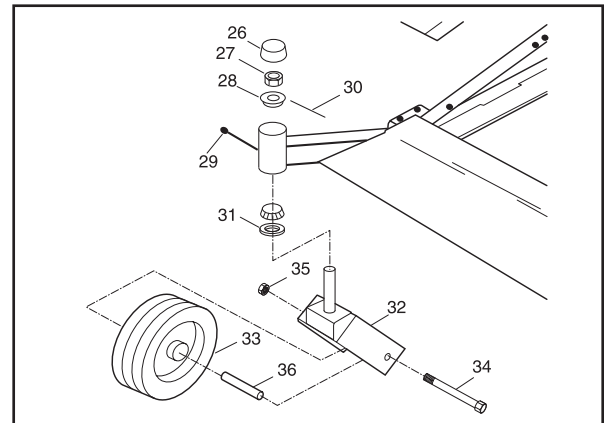

8011-619

*Caster wheels*

Foam filled tires or solid tires will void the warranty.

### Removal and installation of caster wheel

1. Remove nut (35) and caster bolt (34).
2. Pull the wheel out of the fork and take care of the sleeve (36).
3. Install in reverse order. Tighten caster bolt according to instructions above.

## Hardware

Check daily. Inspect the entire machine for loose or missing hardware.

# LUBRICATION

## Lubrication

### Lubrication Schedule

12/12	1/52	1/365	LZ, iZ		25h	50h	100h	200h	300h
								(2x)	
						(2x)			
						(3x)* (2x)**			
			1						
			2			(2x)			
					1				
					11	(2x)			
			3		12			(2x)	
			4		13				
					3				
					14				

\* Tunnel Decks Only  
\*\* Combi Decks Only

8011-765

#### Lubrication schedule

12/12 Every year

1/52 Every week

1/365 Every day

Lubricate with grease gun

Oil change

Filter change

Lubricate with oil can

Level check

## General

Remove the ignition key to prevent unintentional movements during lubrication.

When lubricating with an oil can, it must be filled with engine oil.

When lubricating with grease, unless otherwise stated, use a high grade molybdenum disulfide grease.

For daily use, the machine should be lubricated twice weekly.

Wipe away excess grease after lubrication.

It is important to avoid getting lubricant on the belts or the drive surfaces on the belt pulleys. Should this happen, attempt to clean them with spirits. If the belt continues to slip after cleaning, it must be replaced. Gasoline or other petroleum products must not be used to clean belts.

# LUBRICATION

## Lubricating the Cables

If possible, grease both ends of the cables and move the controls to end stop positions when lubricating. Refit the rubber covers on the cables after lubrication. Cables with sheaths will bind if they are not lubricated regularly. If a cable binds, it can disrupt operation.

If a cable binds, remove the cable and hang it vertically. Lubricate it with light engine oil until the oil begins to escape from the bottom.

Tip: Fill a small plastic bag with oil and tape it so that it seals against the sheath and allow the cable to hang vertically from the bag overnight. If you do not succeed in lubricating the cable, it must be replaced.

## Shaft Bushings and Linkage

Lubricate the bearing of the shafts and linkage for brake system and steering with oil spray or oil can.

## Lubricating in Accordance with the Lubrication Schedule

### 1. Hydraulic System, Oil Level

The hydraulic oil and filter must be replaced every 300 hours, and at least once a year. Contact an authorized service workshop.

Check the oil level in the hydraulic tank daily. The level shall be about 3/4"-1" (19 - 25 mm) below the top of the tank.

Check connections, hoses, and tubes for damage or leaks. Replace or repair if doubtful.

### Changing Oil and Filters

Oil and filter changes should be carried out by an authorized service workshop due to the risk of impurities entering the system.

### 2. Driver's Seat

Tip the seat.

Lubricate the front hinges using an oil can.

Lubricate the lengthways adjustment mechanism with the oil can.

Lubricate the lengthways adjustment runners with the oil can.

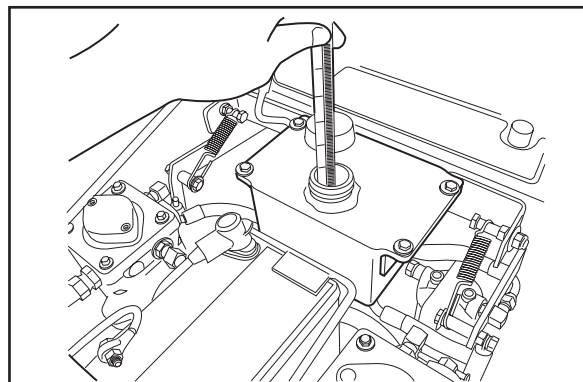

8011-565

Checking the hydraulic oil



#### WARNING!

If a leak is suspected, use a piece of cardboard or wood, NOT your hands, to check for leaks.

Escaping hydraulic oil under pressure can have sufficient force to penetrate the skin, causing serious injury.

If injured by escaping fluid, see a doctor at once. Serious infection or reaction can develop if proper medical treatment is not administered immediately.

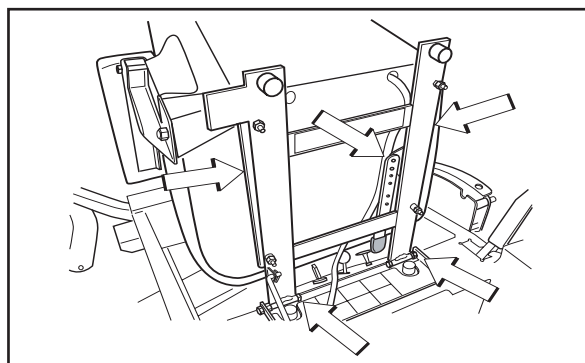

8011-571

Lubricating the lengthways adjuster under the seat

# LUBRICATION

## 3. Engine Oil

### Changing the Engine Oil

The engine oil shall be changed for the first time after 8 hours of operation. Thereafter, it should be changed every 100 hours.



#### WARNING!

The engine and the exhaust system, become very hot during operation.

Risk for burns if touched.

Allow engine and exhaust system to cool at least two (2) minutes.

#### IMPORTANT INFORMATION

Used engine oil is a health hazard and must not be disposed of on the ground or in nature; it should always be disposed of at a workshop or appropriate disposal location.

Avoid skin contact; wash with soap and water in case of spills.

1. Place the machine on a flat surface.
2. Place a container under the engine drain plug.
3. Remove the dipstick and open the drain plug.
4. Allow the oil to run out into the container.
5. Install and tighten the oil drain plug.
6. Replace the oil filter if necessary.
7. Fill with new engine oil in accordance with Checking the Oil Level.
8. Start the engine. Run it for a few seconds. Stop and re-check the oil level.

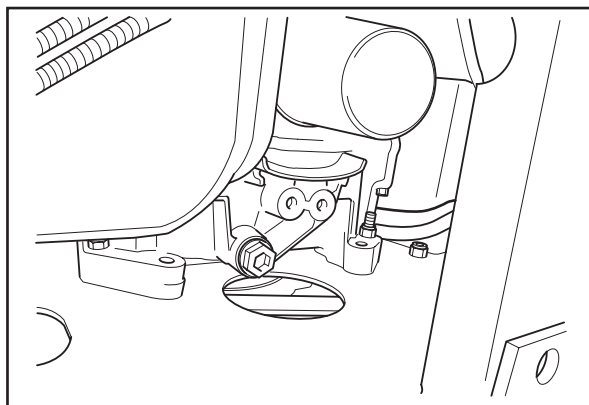

8011-455

*Oil drain plug Kawasaki*

### Checking the Oil Level

Check the oil level in the engine when the machine is standing level and the engine is stopped.

Remove the dipstick, wipe it clean, and then replace it.

The dipstick should **not** be screwed into place.

Take the dipstick out again and read the oil level.

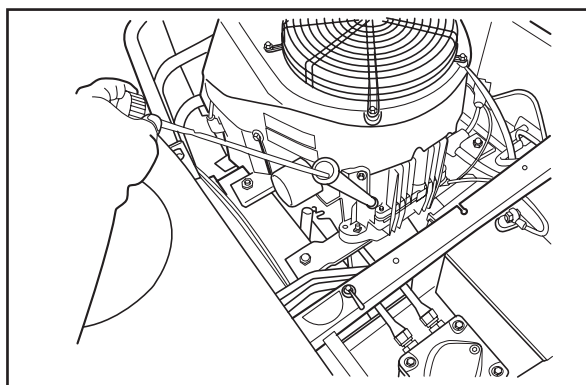

8011-569

*Remove the dipstick*



# LUBRICATION

The oil level shall lie between the markings on the dipstick. If the level is approaching the "ADD" mark, top up the oil to the "FULL" mark on the dipstick.

Never fill above the "FULL" mark.

The oil is filled through the hole for the dipstick.

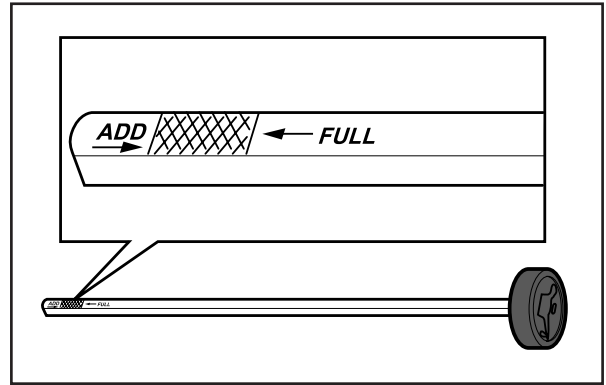

8009-159

The dipstick markings

Use engine oil SAE 30 or SAE 10W-30 or, alternately, 10W/40, class SC-SJ (over +32 °F/0 °C).

Over +68 °F /+20 °C SAE 40 can be used.

Use engine oil SAE 5W-20, class SC-SJ (under +32 °F/0 °C).

The engine holds 1.6 qt/1.5 liters of oil excluding the filter (including filter 1.8 qt/1.7 liters).

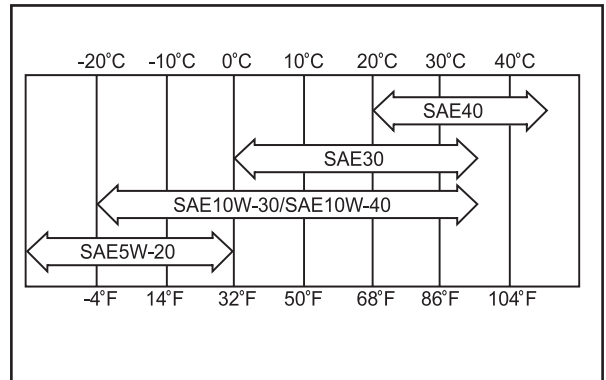

8009-140

Engine oils

## 4. Throttle and Choke Cables, Lever Bearings

Lubricate the cable ends by the carburetor with an oil can. Move the controls to the end points and lubricate again.

The throttle cable is also lubricated by the control when the control console is removed.

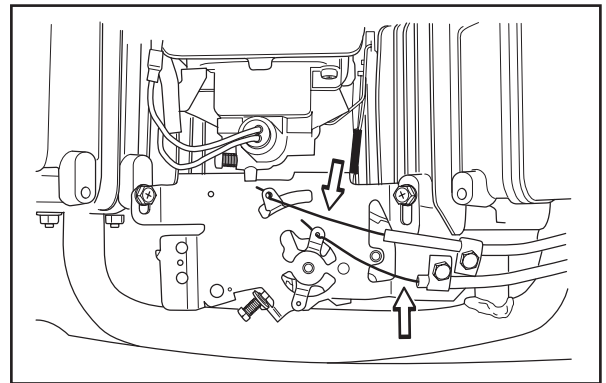

8011-605

Throttle and choke cables by the carburetor

## 5. Front Wheel Mount

Lubricate with a grease gun, one zerk for each wheel mount, until the grease is forced out.

Use only good quality molybdenum disulphide grease.

Grease from well-known brand names (petrochemical companies, etc.) usually maintains a good quality.

# LUBRICATION

## 6. Front Wheel Bearings

Lubricate with a grease gun, one zerk for each set of wheel bearings, until the grease is forced out.

Use only good quality molybdenum disulphide grease.

Grease from well-known brand names (petrochemical companies, etc.) usually maintains a good quality.

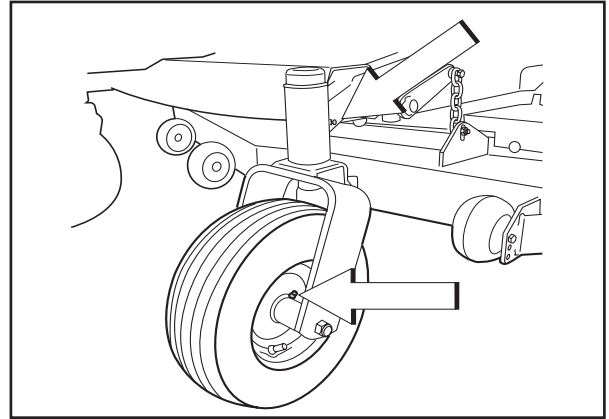

8011-573

*Lubricating the front wheels*

## 7. Deck belt pulleys - Tunnel Deck Only

Lubricate with a grease gun two strokes.

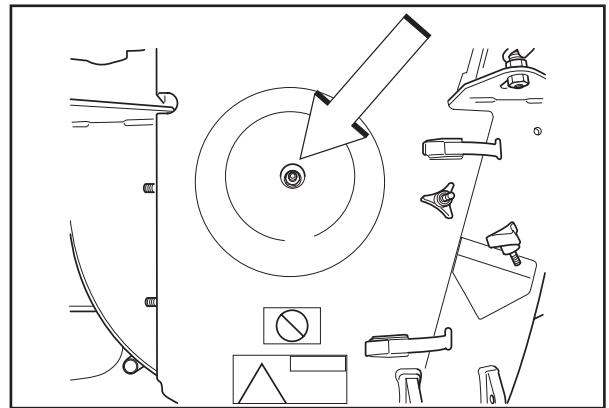

8011-461

*Deck belt pulley*

## 8. Mower Deck Height Adjuster

Lubricate using a grease gun, one zerk, until the grease squeezes out.

Lubricate the lever latch run in in the lever.

Use only good quality molybdenum disulphide grease.

Grease from well-known brand names (petrochemical companies, etc.) usually maintains a good quality.

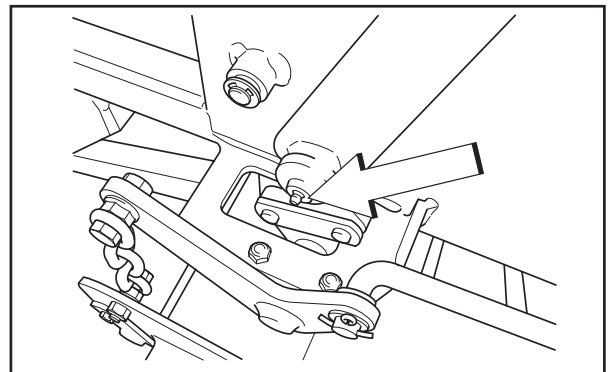

8011-456

*Lubricating the cutting height adjuster*

# LUBRICATION

## 9. Belt Adjuster, Mower Deck

Remove the foot plate (two screws) and lubricate with a grease gun, one zerk, until grease is forced out.

Use only good quality molybdenum disulphide grease.

Grease from well-known brand names (petrochemical companies, etc.) usually maintains a good quality.

### IMPORTANT INFORMATION

**Use minimal lubrication and remove excess lubricant so that it does not come into contact with belts or belt pulley drive surfaces.**

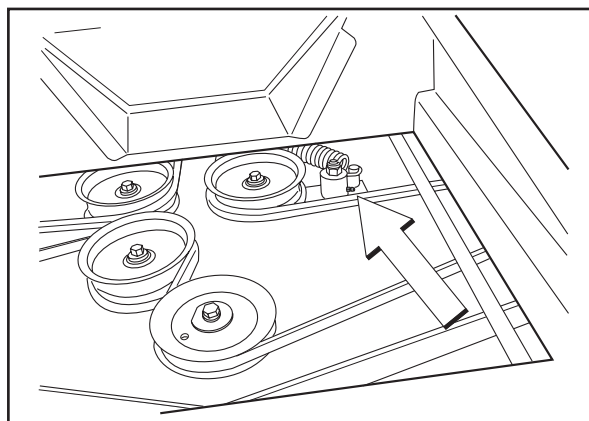

8011-576

*The belt adjuster grease nipple*

## 10. Steering Control Shafts

Tip the driver's seat.

Lubricate with a grease gun, one zerk for each steering control shaft, until the grease is forced out.

Use only good quality molybdenum disulphide grease.

Grease from well-known brand names (petrochemical companies, etc.) usually maintains a good quality.

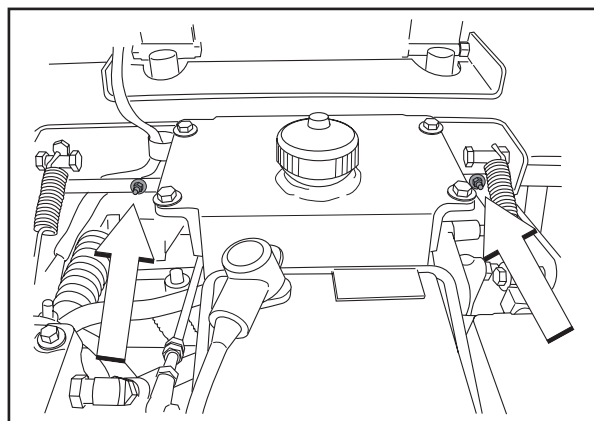

8011-578

*Lubricating the steering control shafts*

## 11. Mower Deck Struts

Lubricate with a grease gun, one zerk for each strut, until the grease is forced out.

Use only good quality molybdenum disulphide grease.

Grease from well-known brand names (petrochemical companies, etc.) usually maintains a good quality.

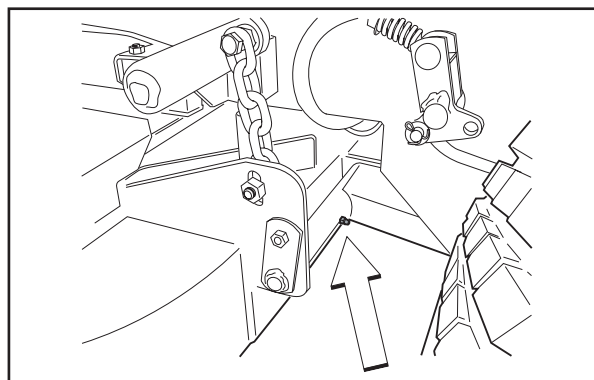

8011-577

*Lubricating struts*

# LUBRICATION

## 12. Brake Arms

Remove one rear wheel at a time (four lug nuts).

Lubricate with a grease gun, one zerk for each brake arm, until the grease is forced out.

Use only good quality molybdenum disulphide grease.

Grease from well-known brand names (petrochemical companies, etc.) usually maintains a good quality.

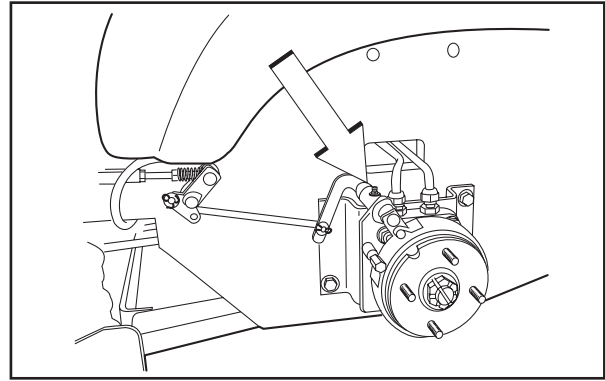

8011-579

*Lubricating brake arms*

### **IMPORTANT INFORMATION**

**Use minimal lubrication and remove excess lubricant so that it does not come into contact with the brake band.**

## 13. Belt Adjuster, Hydraulic Pumps

Lubricate using a grease gun, one zerk, until the grease squeezes out.

Use only good quality molybdenum disulphide grease.

Grease from well-known brand names (petrochemical companies, etc.) usually maintains a good quality.

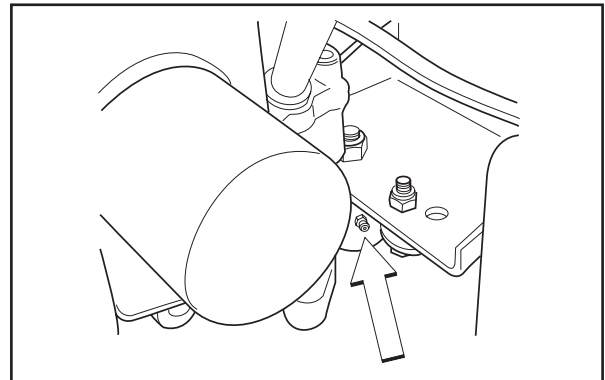

8011-575

*Lubricating the belt adjuster*

### **IMPORTANT INFORMATION**

**Use minimal lubrication and remove excess lubricant so that it does not come into contact with belts or belt pulley drive surfaces.**

---

# LUBRICATION

---

## 14. Changing the Oil Filter

1. Drain the engine oil in accordance with the work description under the heading Engine Oil/Change Engine Oil.
2. Remove the oil filter. If necessary, use a filter remover.
3. Wipe new, clean engine oil onto the seal for the new filter.
4. Mount the filter by hand with + 3/4 turn.
5. Run the engine warm, then check that there are no leaks around the oil filter seal.
6. Check the oil level in the engine, top up if necessary. The oil filter holds 0.2 qt (0.2 liters) of oil.

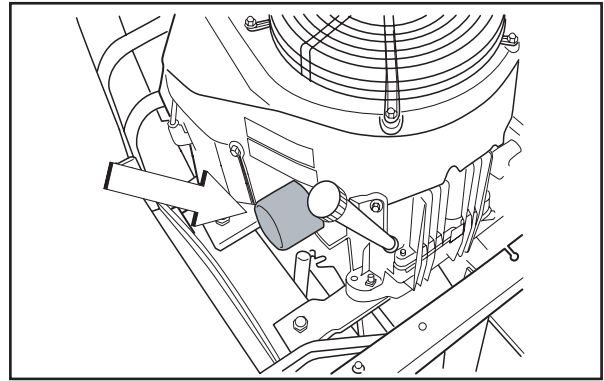

8011-570

*Changing the oil filter*

---

# TROUBLE SHOOTING GUIDE

---

## Trouble Shooting Guide

### Problem

### Cause

---

The engine will not start.

- The blade switch is engaged.
  - The steering controls are not locked in the neutral position.
  - The driver is not sitting in the driver's seat.
  - The parking brake is not activated.
  - The battery is dead.
  - Contamination in the carburetor or fuel line.
  - The fuel supply is closed or the tap for the fuel tanks is in the wrong position.
  - Clogged fuel filter or fuel line.
- 

The starter does not turn the engine over.

- Dead battery.
  - Poor contacts on the battery terminal cable connections.
  - Fuse blown.
  - Ignition system faulty.
  - Fault in the starter safety circuit.  
See "Checking the Safety System" in the Maintenance" section.
- 

The engine runs rough.

- Faulty carburetor.
  - The choke control is pulled out with a warm engine.
  - Defective valves.
  - Defective piston, cylinder, piston ring, or cylinder head seal.
  - The cylinder head bolts are loose.
  - Clogged fuel filter or jet.
  - Clogged ventilation valve on the fuel cap.
  - Fuel tank nearly empty.
  - Defective spark plugs.
  - The spark plugs are loose.
  - Defective ignition cable.
  - Defective spark plug electrode.
  - Defective spark plug connection.
  - Rich fuel mixture or fuel-air mixture.
  - Wrong fuel type.
  - Water in the fuel.
  - Clogged air filter.
- 

The engine seems weak.

- Clogged air filter.
- Defective spark plugs.
- Carburetor incorrectly adjusted.

---

# TROUBLE SHOOTING GUIDE

---

The engine overheats.

- Clogged air intake or cooling fins.
- Engine overloaded.
- Poor ventilation around engine.
- Defective engine speed regulator.
- Soot in the combustion chamber.
- Too little or no oil in the engine.
- Defective spark plugs.
- Pre-ignition incorrect.

---

Battery not charging.

- Poor contact with battery terminal cable connectors.

---

The machine moves slowly, unevenly, or not at all.

- Parking brake on.
- Bypass valve on pump open.
- Drive belt for the pump slack or has come off.
- Defective hydraulic system.
- Air in the hydraulic system.

---

Mower deck not engaging.

- Drive belt for the mower deck has come loose.
- Contact for the electromagnetic coupling has loosened.
- The blade switch is faulty or has come loose from the cable contact.
- The fuse has blown.

---

Uneven mowing results.

- Different air pressure in the tires on the left and right sides.
- Bent blades.
- The chains for suspending the mower deck are uneven.
- The chain fixture has come loose.
- The blades are blunt.
- Driving speed too high.
- The grass is too long.
- Grass collected under the mower deck.

---

The machine vibrates.

- The blades are loose.
  - The blades are incorrectly balanced.
  - The engine is loose.
-

---

# STORAGE

---

## Storage

### Winter Storage

At the end of the mowing season, the machine should be readied for storage (or if it will not be in use for longer than 30 days). Fuel allowed to stand for long periods of time (30 days or more) can leave sticky residues that can plug the carburetor and disrupt engine function.

Fuel stabilizers are an acceptable option as regards sticky residues during storage.

Add stabilizer to the fuel in the tank or in the storage container. Always use the mixing ratios specified by the manufacturer of the stabilizer. Run the engine for at least 10 minutes after adding the stabilizer so that it reaches the carburetor. Do not empty the fuel tank and the carburetor if you have added stabilizer.



#### **WARNING!**

**Never store an engine with fuel in the tank indoors or in poorly ventilated spaces where fuel vapor can come in contact with open flames, sparks, or a pilot light such as in a boiler, hot water tank, clothes drier, etc. Handle the fuel with care. It is very flammable and careless use can cause serious personal injury and property damage. Drain the fuel into an approved container outdoors and far away from open flame. Never use gasoline for cleaning. Use a degreaser and warm water instead.**

To ready the machine for storage, follow these steps:

1. Thoroughly clean the machine, especially under the mower deck. Touch up damage to the paint and spray a thin layer of oil on the underside of the mower deck to avoid corrosion.
2. Inspect the machine for worn or damaged parts and tighten any nuts or screws that may have become loose.
3. Change the engine oil; dispose of properly.
4. Empty the fuel tanks or add a fuel stabilizer. Start the engine and allow it to run until the carburetor is drained of fuel or the stabilizer has reached the carburetor.
5. Remove the spark plugs and pour about a tablespoon of engine oil into each cylinder. Turn over the engine so that the oil is evenly distributed and then refit the spark plugs.
6. Lubricate all grease zerks, joints, and axles.
7. Remove the battery. Clean, charge, and store the battery in a cool place, but protect it from direct cold.
8. Store the machine in a clean, dry place and cover it for extra protection.

### Service

When ordering spare parts, please specify the purchase year, model, type, and serial number.

Always use genuine Husqvarna spare parts.

An annual check-up at an authorized service workshop is a good way to ensure that your machine performs its best the following season.



# WIRING DIAGRAMS

## Wiring diagram

6. Seat unoccupied

8. Blade switch in OFF position

11. Brake switch OFF pos.

14-15. Motion control levers OUT

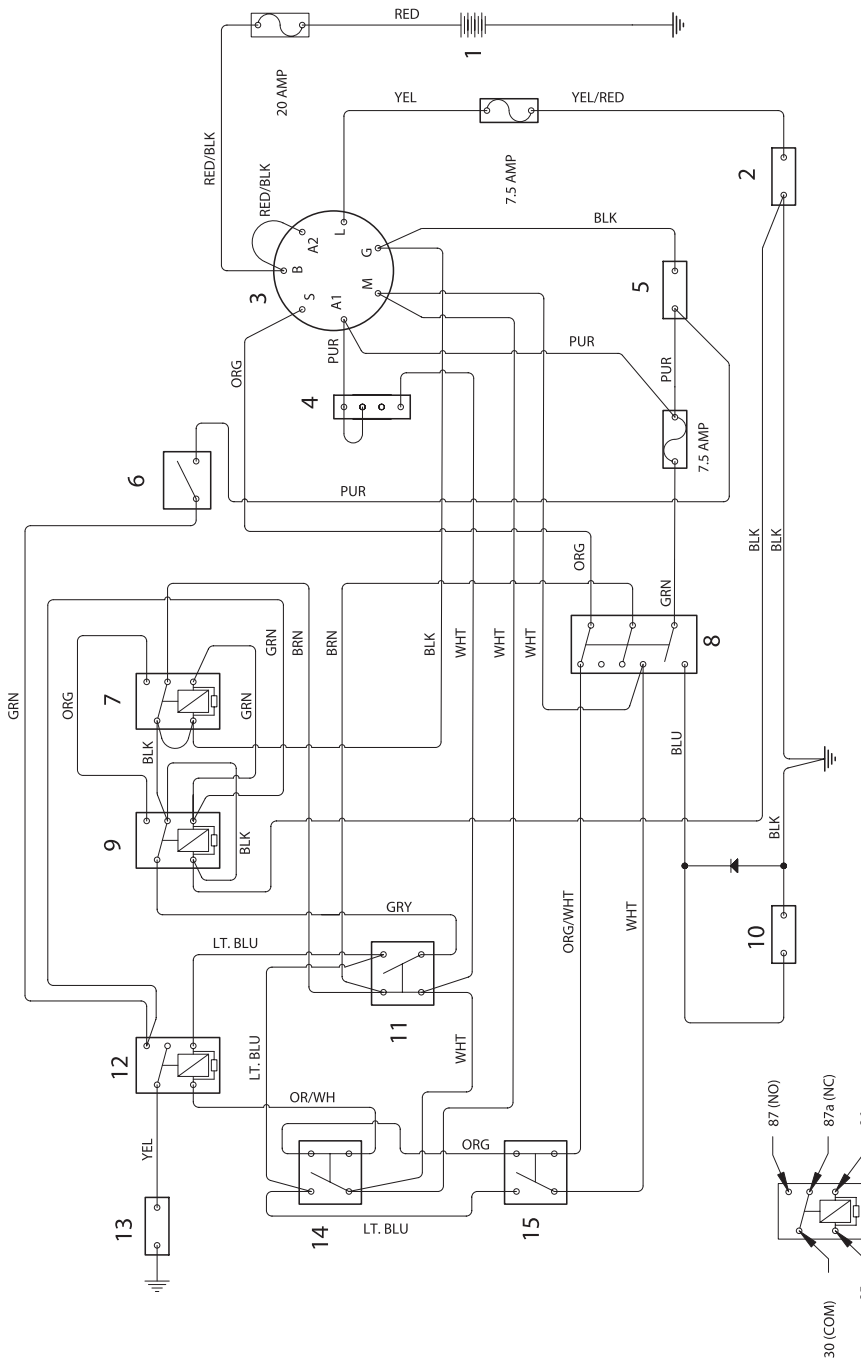
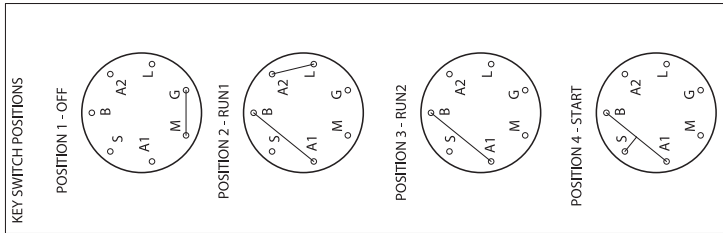

1. Battery
2. Accessory outlet
3. Key switch
4. To engine pigtail
5. Hour meter
6. Seat switch
7. Run relay
8. Blade switch
9. Brake relay
10. Electric clutch
11. Brake switch
12. Start relay
13. Starter solenoid
14. Left motion control lever
15. Right motion control lever

- BLK = Black  
 BLU = Blue  
 BRN = Brown  
 GRN = Green  
 GRY = Grey  
 LT. BLU = Light Blue  
 ORG = Orange  
 PUR = Purple  
 RED = Red  
 WHT = White  
 YEL = Yellow  
 NO = Normally Open  
 NC = Normally Closed  
 COM = Common

8011-650

# TECHNICAL DATA

Engine	iZ21C
<b>Manufacturer</b>	Kawasaki
Type	FH721V
Power	21 hp / 15.4 kW*
Lubrication	Pressure with oil filter
Oil capacity excl filter	1.6 qt / 1.5 liters
Oil capacity incl filter	1.8 qt / 1.7 litres
Engine oil (See viscosity diagram)	SAE 10W30, 10W40 SAE 30, SAE 40, API SF-SJ
Fuel	Min 87 octane unleaded (Max methanol 5%, max ethanol 10%, Max MTBE 15%)
Fuel tank capacity	11.4 gallons / 43 liters
Spark plugs / gap	NGK BPR4ES .030" / 0.75 mm
Cooling	Air-cooled
Air filter	Heavy duty canister
Alternator	12 V 15 A
Starter	Electric
<b>Transmission</b>	
Transmission	Dual pumps, Wheel drive motors
Speed and direction controls	Dual levers, foam gripped
Speed forward	0-9.5 mph / 15.3 km/h
Speed reverse	0-5 mph / 0-8 km/h
Brakes	Hydrostatic/brake linings
Front caster tires, Smooth tread	13 x 5-6
Rear tires, Turf pneumatic	23 x 9.5-12
Tire pressure, front and rear	15 PSI / 103 kPa / 1 bar
Hydraulic reservoir + system	3 qt / 2.8 liter
Hydraulic oil	Full synthetic 15W-50

\* The power rating of the engine indicated is the average net power output (at specified rpm) of a typical production engine for the engine model measured to SAE standard J1349/ISO1585. Mass production engines may differ from this value. Actual power output for the engine installed in the final machine will depend on the operating speed, environmental conditions and other variables.

# TECHNICAL DATA

iZ21C	48" Tunnel Deck	48" Combi Deck
<b>Frame</b>		
Cutting Height	1½" - 5" / 3.8 cm - 12.7 cm	1¼" - 4¾" / 3.2 cm - 12.1 cm
Uncut Circle	0" / 0 cm	0" / 0 cm
Blades	3	3
Blade Length	16¼" / 413 mm	16¾" / 425 mm
Blade Tip Speed	16,780 fpm / 85.2 m/s	15,655 / 79.5 m/s
Anti-scalp Rollers	3 adjustable	2 adjustable
Frame Construction	Steel uni-frame	Steel uni-frame
Ball Bearinged Wheels	Yes	Yes
Sprung Standard Seat	Standard Pan Style	Standard Pan Style
Hinged Arm Rests	Yes	Yes
Blade Engagement	200 ft/lb Warner Mag Stop Electromagnetic Clutch	200 ft/lb Warner Mag Stop Electromagnetic Clutch
Deck Construction	7 Gauge Tunnel, 10 Gauge Deck Welded and Formed Steel	4.5 mm Stamped Shell
<b>Productivity</b>		
Rate	3.8 acres/h / 15405 m <sup>2</sup> /h	3.8 acres/h / 15405 m <sup>2</sup> /h
<b>Overall Dimensions</b>		
Weight	870 lbs / 395 kg	870 lbs / 395 kg
Base Machine Length	76" / 193 cm	76" / 193 cm
Base Machine Width	49" / 125 cm	49" / 125 cm
Base Machine Height	42" / 107 cm	42" / 107 cm
Overall Width, Chute Up	49" / 125 cm	49" / 125 cm
Overall Width, Chute Down	61" / 155 cm	61" / 155 cm
<b>Vibration</b>		
Daily Exposure		
Hand / Arm A(8)	1.62 m/s <sup>2</sup>	1.24 m/s <sup>2</sup>
Whole Body A(8)	0.32 m/s <sup>2</sup>	0.10 m/s <sup>2</sup>
Equivalent Vibration		
Hand A <sub>HV</sub>	1.87 m/s <sup>2</sup>	1.43 m/s <sup>2</sup>
Whole Body A <sub>HV</sub>	0.37 m/s <sup>2</sup>	0.11 m/s <sup>2</sup>
Standard Deviation		
Hand	0.21 m/s <sup>2</sup>	0.17 m/s <sup>2</sup>
Whole Body	0.05 m/s <sup>2</sup>	0.02 m/s <sup>2</sup>
<b>Sound</b>		
Operator Ear*	91 dB(A)	91 dB(A)
Guaranteed Value	105 dB(A)	105 dB(A)
Measured Value	104 dB(A)	104 dB(A)

\* Noise pressure level according to EN 836. Reported data for noise pressure level has a typical statistical dispersion (standard deviation) of 1.0 dB(A). If the machine can be equipped with different cutting decks, the noise pressure levels are stated in order starting from the cutting deck with the smallest cutting width.

# TECHNICAL DATA

## Accessories

Tunnel Decks -

BioClip attachment (Mulch kit)

Front baffle kit

### U.S. Standard Hardware

	Grade	SAE Grade 5		SAE Grade 8		Flangelock Screw w/Flangelock Nut	
	ft./lbs	ft./lbs	Nm	ft./lbs	Nm	ft./lbs	Nm
Shank Size (Diameter in inches, fine or coarse thread)	¼	9	12	13	18		
	5/16	18	24	28	38	24	33
	3/8	31	42	46	62	40	54
	7/16	50	68	75	108		
	½	75	102	115	156		
	9/16	110	150	165	224		
	5/8	150	203	225	305		
	¾	250	339	370	502		
	7/8	378	513	591	801		
	1 1/8	782	1060	1410	1912		

\*\* Grade 5 - Minimum commercial quality (lower quality not recommended)

### Metric Standard Hardware

	Grade	Grade 8.8		Grade 10.9		Grade 12.9	
	ft./lbs	ft./lbs	Nm	ft./lbs	Nm	ft./lbs	Nm
Shank Size (Diameter in millimeters, fine or coarse thread)	M4	1.5	2	2.2	3	2.7	3.6
	M5	3	4	4.5	6	5.2	7
	M6	5.2	7	7.5	10	8.2	11
	M7	8.2	11	12	16	15	20
	M8	13.5	18	18.8	25	21.8	29
	M10	24	32	35.2	47	43.5	58
	M12	43.5	58	62.2	83	75	100
	M14	70.5	94	100	133	119	159
	M16	108	144	147	196	176	235
	M18	142	190	202	269	242	323
	M20	195	260	275	366	330	440
	M22	276	368	390	520	471	628
	M24	353	470	498	664	596	794
	M27	530	707	474	996	904	1205

When this product is worn out and no longer used, it shall be returned to the reseller or other party for recycling.

### TORQUE SPECIFICATIONS – HEX HEAD CAP SCREWS

The torque values shown should be used as a general guideline when specific torque values are not given.

---

# CONFORMITY CERTIFICATES

---

## Conformity Certificates For Model Listed Below:

**Model 968999306/iZ21C Zero Turn Rider (Serial Numbers 054600001 and after)**

**with Deck Model 968999342 TRD48 (Serial Numbers: 054600001 - 10199999)**

**Deck Model 968999347 CD48**

### USA requirements

Labels are placed on the engine and/or in the engine compartment stating that the machine will fulfill the requirements. This is also applicable to special requirements for any of the states, (California emission rules etc.). Do not remove any of these labels. Certificates can also be supplied with the machine at delivery or written in the Engine manual. Take care of them as they are valuable documents.

### EU declaration of conformity (Only applicable to European versions)

See the Declaration of Conformity Certificate for additional information.

Husqvarna AB, Beatrice NE USA declares under sole responsibility that the machine types stated on page 1 of this manual, from 2005's serial numbers and onwards (the year is clearly stated in plain text on the rating plate with subsequent serial number), complies with the requirements of the COUNCIL'S DIRECTIVES:

- of May 17, 2006 "relating to machinery" 2006/42/EC, annex IIA.
- of December 15, 2004 "relating to electromagnetic compatibility" 2004/108/EC and applicable supplements.
- of May 8, 2000 "relating to the emission of noise to surroundings" 2000/14/EC.

The following harmonised standards have been applied: EN292-2, EN836.

### Business Name & Address:

Husqvarna Turf Care  
401 North Commerce  
Beatrice, NE 68310 USA

### Notified Body:

SNCH, 11 Route de Luxembourg, L-5230 Sandweiler, has issued reports regarding the assessment of conformity according annex VI of the COUNCIL'S DIRECTIVE of May 8, 2000 "relating to the noise emissions in the environment" 2000/14EC.

# SERVICE JOURNAL

## Service Journal

Action	Date, mtr reading, stamp, sign
<b>Delivery Service</b>	
1. Charge the battery.	<input type="checkbox"/>
2. Mount the rear wheels.	<input type="checkbox"/>
3. Adjust the tire pressure of all wheels to 15 PSI (1 bar).	<input type="checkbox"/>
4. Mount the steering controls in the normal position.	<input type="checkbox"/>
5. Connect the seat fold-up stop.	<input type="checkbox"/>
6. Connect the cable to the safety switch under the seat.	<input type="checkbox"/>
7. Mount the arm rests on the seat s back support.	<input type="checkbox"/>
8. Check that the right amount of oil is in the engine.	<input type="checkbox"/>
9. Check that the right amount of oil is in the hydraulic tank.	<input type="checkbox"/>
10. Adjust the position of the steering controls.	<input type="checkbox"/>
11. Fill with fuel and open the fuel valve.	<input type="checkbox"/>
12. Check that the machine has no transport damage.	<input type="checkbox"/>
13. Start the engine.	<input type="checkbox"/>
14. Check that there is drive to both wheels.	<input type="checkbox"/>
15. Bleed the hydraulic system if necessary.	<input type="checkbox"/>
16. Mount the cutting deck.	<input type="checkbox"/>
17. Check the mower deck adjustment.	<input type="checkbox"/>
18. Check:	
The safety switch for the parking brake.	<input type="checkbox"/>
The safety switch for the mower deck.	<input type="checkbox"/>
The safety switch in the seat.	<input type="checkbox"/>
The safety switch in the steering controls.	<input type="checkbox"/>
Parking brake functionality.	<input type="checkbox"/>
Driving forward.	<input type="checkbox"/>
Driving backward.	<input type="checkbox"/>
Engaging the blades.	<input type="checkbox"/>
19. Check the idle speed.	<input type="checkbox"/>
20. Check the engine high idle speed.	<input type="checkbox"/>

---

# SERVICE JOURNAL

---

Action	Date, mtr reading, stamp, sign
<p>20. Inform the customer about:</p> <ul style="list-style-type: none"><li>The need and advantages of following the service schedule.</li><li>The need and advantages of leaving the machine for service every 300 hours.</li><li>The effects of service and maintaining a service journal on the machine s resale value.</li><li>Application areas for BioClip.</li></ul> <p>21. Fill in the sales papers, etc.</p>	<p>Delivery service has been carried out.</p> <p>No remaining notes.</p> <p>Certified:</p>
<p><b>After the First 8 Hours</b></p> <p>1. Change engine oil.</p>	<p><input type="checkbox"/></p>

---

# SERVICE JOURNAL

---

Action	Date, mtr reading, stamp, sign
<p><b>25-Hour Service</b></p> <ol style="list-style-type: none"><li>1. Check the fuel pump s air filter.</li><li>2. Check the hydraulic system s oil level.</li><li>3. Check the tire pressures.</li><li>4. Lubricate the belt adjuster, mower deck.</li><li>5. Lubricate the belt adjuster, hydraulic pumps.</li><li>6. Check/clean the engine s cooling air intake.</li><li>7. Clean cyclon air filter dust cap.</li></ol>	



---

# SERVICE JOURNAL

---

Action	Date, mtr reading, stamp, sign
<p><b>50-Hour Service</b></p> <ol style="list-style-type: none"><li>1. Perform the 25-hour service.</li><li>2. Lubricate the front wheel bearings.</li><li>3. Lubricate the steering control shafts.</li><li>4. Lubricate the mower deck struts.</li><li>5. Lubricate the cutting height adjuster.</li><li>6. Check/adjust the parking brake.</li></ol>	

---

# SERVICE JOURNAL

---

Action	Date, mtr reading, stamp, sign
<p><b>100-Hour Service</b></p> <ol style="list-style-type: none"><li>1. Perform the 25-hour service.</li><li>2. Perform the 50-hour service.</li><li>3. Change engine oil.</li><li>4. Check whether the hydraulic oil needs changing (every 300 hours).</li><li>5. Check whether the engine oil filter needs changing (every 200 hours).</li><li>6. Clean/replace the spark plugs.</li><li>7. Replace the fuel filter.</li><li>8. Clean the cooling fins on the engine.</li><li>9. Check V-belts.</li><li>10. Check tighten caster wheel axle bolts (every 200 hours).</li><li>11. Clean and check the need to change the air filter s paper cartridge (every 200 hours).</li><li>12. Replace main air filter cartridge (200h).</li></ol>	

---

# SERVICE JOURNAL

---

Action	Date, mtr reading, stamp, sign
<p><b>300-Hour Service</b></p> <ol style="list-style-type: none"><li>1. Inspect the machine. Come to agreement with the customer as to which additional work is to be carried out.</li><li>2. Perform the 25-hour service.</li><li>3. Perform the 50-hour service.</li><li>4. Perform the 100-hour service.</li><li>5. Change the oil and filter in the hydraulic system.</li><li>6. Clean the combustion chamber and grind the valve seats.</li><li>7. Check the play in the engine valves.</li><li>8. Dismantle and inspect starter (500 h).</li></ol>	

---

# SERVICE JOURNAL

---

Action	Date, mtr reading, stamp, sign
<p><b>At Least Once Each Year</b></p> <ol style="list-style-type: none"><li>1. Clean the engine s cooling air intake (25 hours).</li><li>2. Replace the air cleaner s pre-filter (Oil-foam) (300 hours).</li><li>3. Replace the air filter s main cartridge (200 hours).</li><li>4. Change the engine oil (100 hours).</li><li>5. Replace the engine oil filter (200 hours).</li><li>6. Change the oil and filter in the hydraulic system (300 hours).</li><li>7. Check/adjust the cutting height.</li><li>8. Check/adjust the parking brake (50 hours).</li><li>9. Clean/Change the spark plugs (100 hours).</li><li>10. Change the fuel filter (100 hours).</li><li>11. Clean the cooling fins (100 hours).</li><li>12. Check the play in the engine valves (300 hours).</li><li>13. Perform the 300-hour service at an authorized service workshop.</li></ol>	







**Original instructions**  
**115 36 97-26**



**2010W19**