

LT2118A2

Spare parts

Ersatzteile

Pièces détachées

Reserve onderdelen

Repuestos

Reservdelar

ILLUSTRATED PARTS LIST

MFG. ID NO. 96011012900

CUSTOMER CATALOG NO. LT2118A2

PRODUCT NO. 960 11 01-29

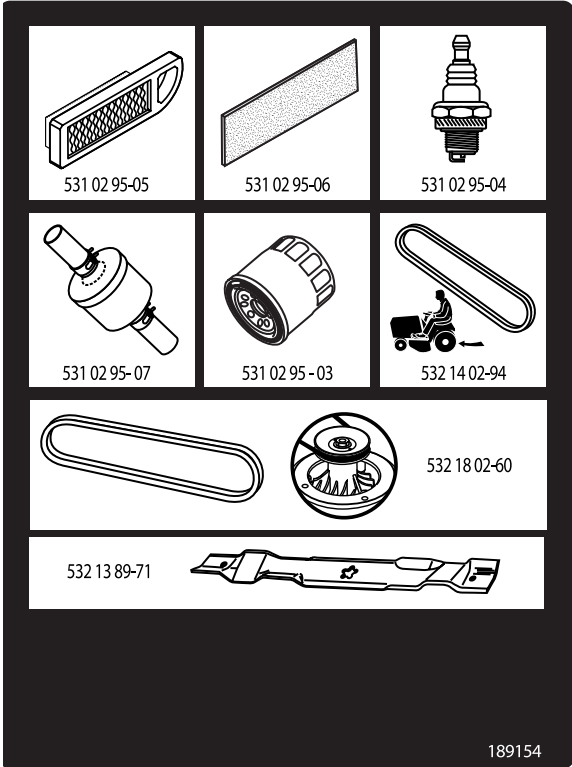

189154

TRACTOR - MODEL NO. LT2118A2 (96011012900), PRODUCT NO. 960 11 01-29 SCHEMATIC

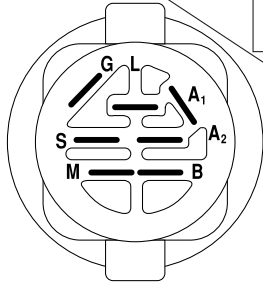
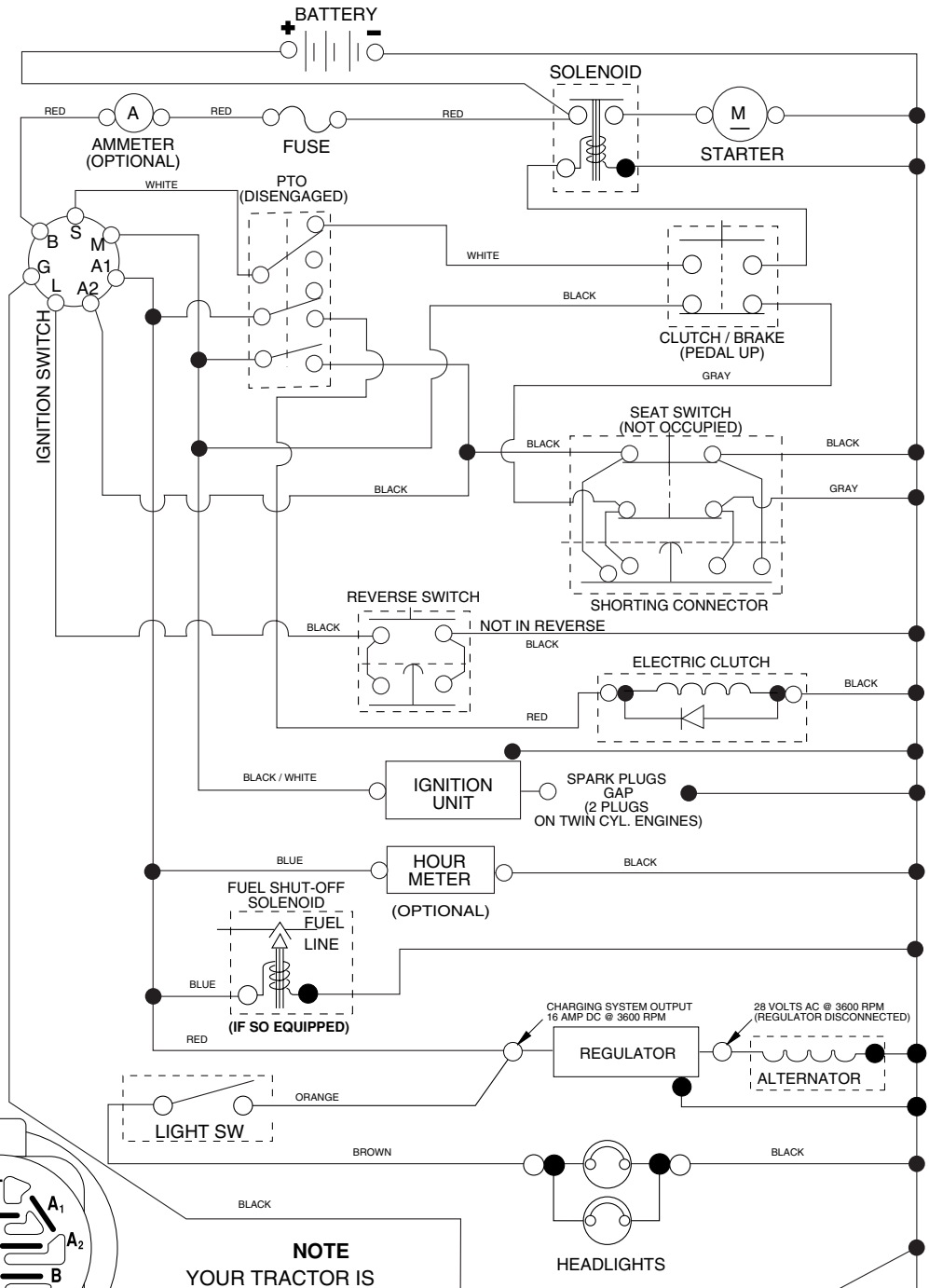

IGNITION SWITCH

POSITION	CIRCUIT	"MAKE"
OFF	M+G+A1	
RUN/OVERRIDE	B+A1	
RUN	B+A1	L+A2
START	B + S + A1	

03113

NOTE

YOUR TRACTOR IS EQUIPPED WITH A SPECIAL ALTERNATOR SYSTEM. THE LIGHTS ARE NOT CONNECTED TO THE BATTERY, BUT HAVE THEIR OWN ELECTRICAL SOURCE. BECAUSE OF THIS, THE BRIGHTNESS OF THE LIGHTS WILL CHANGE WITH ENGINE SPEED. AT IDLE THE LIGHTS WILL DIM. AS THE ENGINE IS SPEEDED UP, THE LIGHTS WILL BECOME THEIR BRIGHTEST.

NON-REMOVABLE CONNECTIONS

REMOVABLE CONNECTIONS

WIRING INSULATED CLIPS

NOTE: IF WIRING INSULATED CLIPS WERE REMOVED FOR SERVICING OF UNIT, THEY SHOULD BE REPLACED TO PROPERLY SECURE YOUR WIRING.

REPAIR PARTS

TRACTOR - MODEL NO. LT2118A2 (96011012900), PRODUCT NO. 960 11 01-29
DECALS

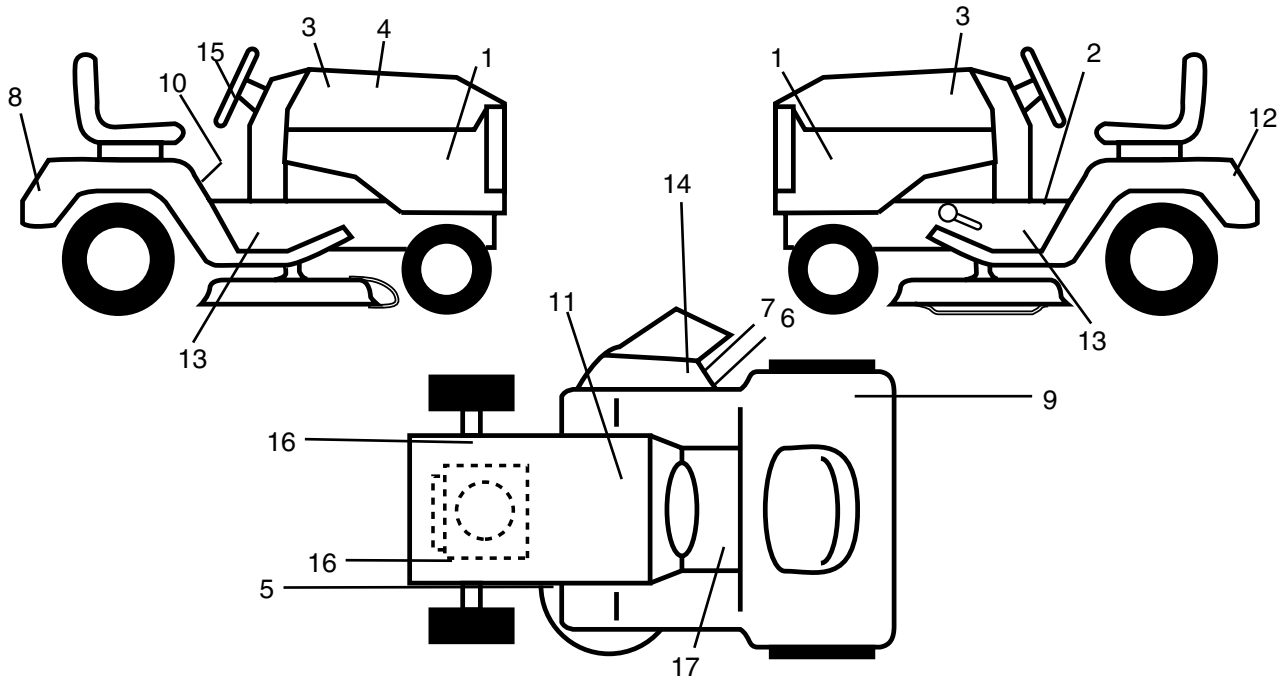

KEY NO.	PART NO.	DESCRIPTION	KEY NO.	PART NO.	DESCRIPTION
1	532 18 88-76	Decal Hood Side Panel	11	532 14 50-05	Decal, Bat Dan/Poi P/L Sym
2	532 14 08-37	Decal, Brake Parking Sandle	12	532 40 17-46	Decal, Fender
3	532 18 95-53	Decal, Hood RH/LH	13	532 40 11-46	Decal, Warning Service/Fire
4	532 18 91-54	Decal, Replacement	14	532 17 91-28	Decal, Deck "B" 42"
5	532 16 03-96	Decal, V-Belt Sch.	15	532 18 57-73	Decal, Logo Steering Wheel Cap
6	532 19 63-57	Decal, Defl. Warn. Cutfinger	16	532 15 97-36	Decal, Chassis Hot Muffler
7	532 18 21-66	Decal, Mower Cutfinger Symbol	17	532 15 97-37	Decal, Brake/Clutch Symbol LT
8	532 18 39-30	Decal, Logo, Fender	--	532 16 25-98	Decal, Drawbar Load Limit
9	532 18 04-32	Decal, 100 DB/CE	--	532 16 69-60	Decal, By-Pass Lt Hydro
10	532 40 03-89	Decal, Warning Symbols CE	--	532 18 82-52	Pad, Footrest LH
			--	532 18 82-53	Pad, Footrest RH
			--	532 40 17-38	Manual, Operator's (Euro)

WHEELS & TIRES

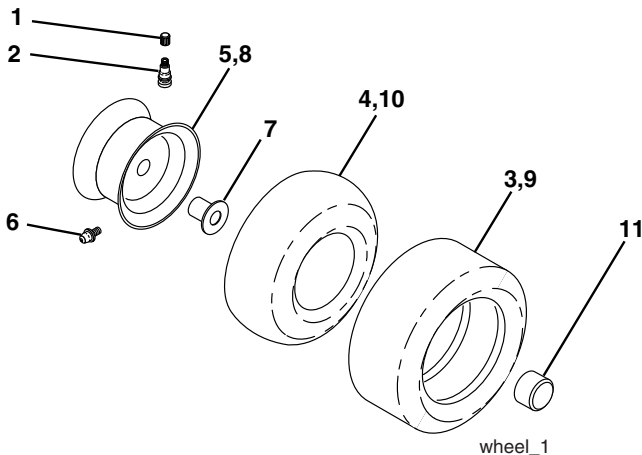

KEY NO.	PART NO.	DESCRIPTION
1	532 05 91-92	Cap Valve Tire
2	532 06 51-39	Stem Valve
3	532 10 62-22	Tire F Ts 15 x 6 0 - 6 Service
4	532 05 99-04	Tube Front (Service Item Only)
5	532 13 83-36	Rim Asm 6"front Service
6	532 12 49-57	Fitting Grease (Front Wheel Only)
7	532 12 49-59	Bearing Flange (Front Wheel Only)
8	532 13 83-37	Rim Asm 8"rear Service
9	532 12 20-82	Tire R Ts 20 x 10-8 C Service
10	532 12 49-26	Tube Rear (Service Item Only)
11	532 17 50-39	Cap Axle Blk 1 50 x 1 00
--	532 14 43-34	Sealant, Tire (10 oz. tube)

NOTE: All component dimensions given in U.S. inches
1 inch = 25.4 mm

REPAIR PARTS

TRACTOR - MODEL NO. LT2118A2 (96011012900), PRODUCT NO. 960 11 01-29
ELECTRICAL

KEY NO.	PART NO.	DESCRIPTION
1	532 14 49-27	Battery
2	874 76 04-12	Bolt Hex Hd 1/4-20 Unc x 3/4
8	532 12 48-86	Tray Battery 7.80 x 5.25
10	532 14 52-11	Bolt Btr Frt 1/4-20 x 7.5
11	532 15 01-09	Holddown Battery Front
12	532 14 57-69	Nut Push Nylon 1/4
16	532 17 61-38	Switch Interlock Push-In
21	532 17 56-88	Harness Asm Light W/4152J
22	532 00 41-52	Bulb Light #1156
25	532 18 68-46	Cable Battery 6 Ga W/pos wire
26	532 17 51-58	Fuse 20 AMP
27	873 51 04-00	Nut Keps Hex 1/4-20 Unc
28	532 14 54-91	Cable Ground
29	532 19 27-49	Switch Seat
30	532 19 33-50	Switch Ignition Delta Push-In
33	532 14 04-01	Key Ign Molded Generic Delta
34	532 11 07-12	Switch Light
40	532 19 74-40	Harness Ign.
42	532 15 43-36	Cover Terminal Red
45	532 17 75-00	Ammeter Round Delta
46	532 17 75-01	Hourmeter Round Delta
50	532 17 46-51	Switch PTO
55	817 49 05-08	Screw Thdrol 5/16-18 x 1/2
79	532 17 52-42	Bulb Holder Asm
92	532 19 66-15	Harness Pigtail
93	532 19 25-40	Screw Plastite 10-14 x 2.0
94	532 19 18-34	Module Reverse

NOTE: All component dimensions given in U.S. inches
1 inch = 25.4 mm.

REPAIR PARTS

TRACTOR - MODEL NO. LT2118A2 (96011012900), PRODUCT NO. 960 11 01-29
CHASSIS AND ENCLOSURES

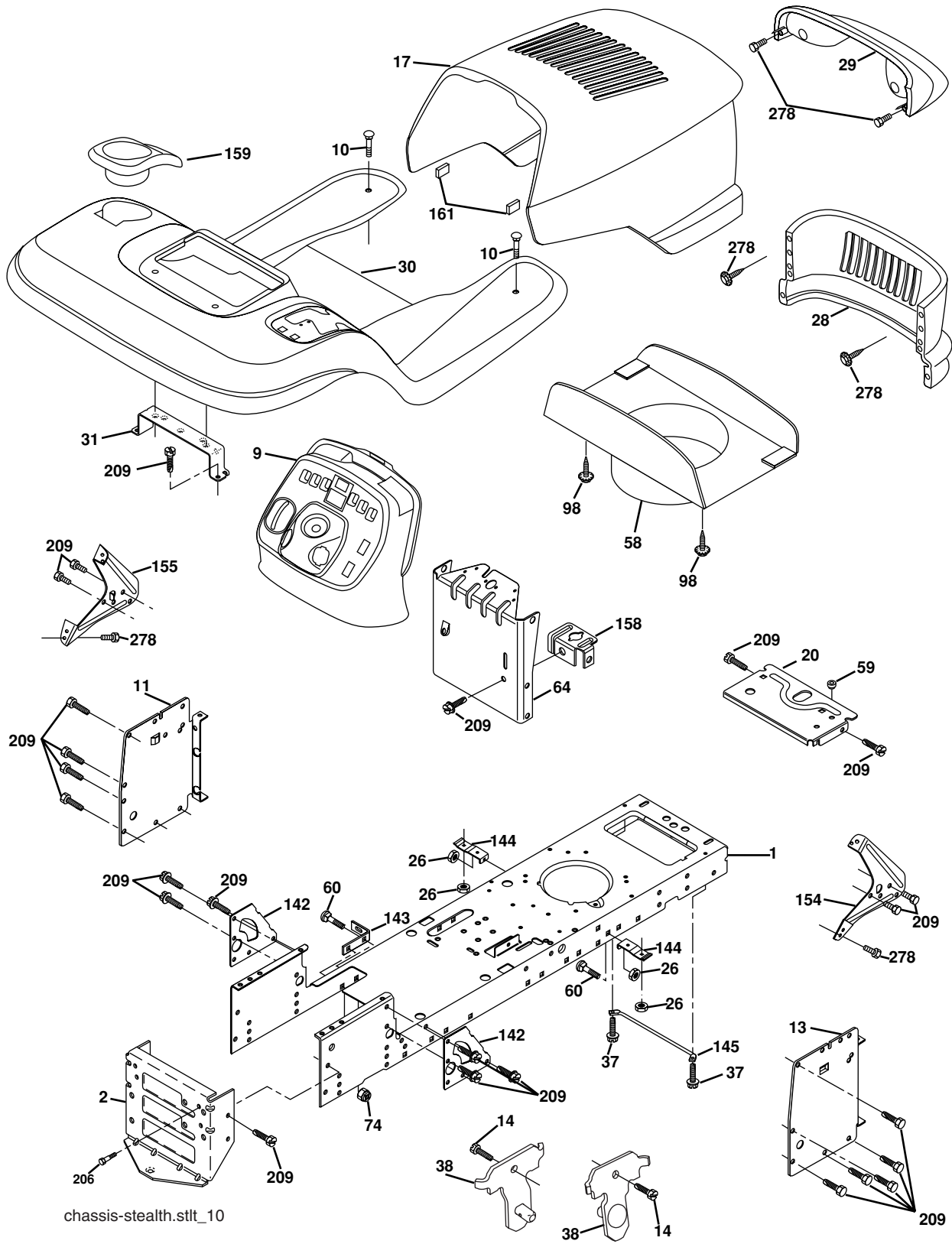

chassis-stealth.stlt_10

REPAIR PARTS

TRACTOR - MODEL NO. LT2118A2 (96011012900), PRODUCT NO. 960 11 01-29
CHASSIS AND ENCLOSURES

KEY NO.	PART NO.	DESCRIPTION
1	532 17 46-19	Chassis Wldmt.
2	532 17 65-54	Drawbar 12 Ga
9	532 19 49-28	Dash
10	872 14 06-08	Bolt RdHd Sqnk. 3/8-16 x 1
11	532 16 72-03	Panel Asm. Dash Lh
13	532 17 82-98	Panel Dash Rh
14	817 49 06-08	Screw Thdrol 3/8-16 x 1/2
17	532 18 13-51	Hood Pnt
20	532 16 20-26	Plate Mtg Battery
26	873 80 06-00	Nut Lock Hex w/Ins 3/8-16 Unc
28	532 18 13-52	Grill w/Clips
29	532 17 97-61	Lens Grille
30	532 40 14-91	Fender /Ftrest Pnt STL
31	532 13 99-76	Bracket Fender
37	817 49 05-08	Screw Thdrol 5/16-18 x 1/2
38	532 17 57-10	Bracket Asm. Pvt. Mwr. Rear
58	532 17 53-51	Duct Air
59	532 18 74-95	Bushing Snap Split
60	872 14 06-06	Bolt Rdhd Sqnk 3/8-16 Unc x 3/4
64	532 17 49-97	Dash Lower
74	873 68 06-00	Nut, Crownlock 3/8-16 Unc
98	532 19 25-12	Screw 10 x 3/4 Single Lead Hex
142	532 17 57-02	Plate Reinforcement STLT
143	532 18 66-89	Bracket Sway Bar
144	532 17 55-82	Bracket Footrest STLT
145	532 15 65-24	Rod Pivot Chassis/Hood
154	532 16 18-97	Bracket Dash STL RH
155	532 16 19-00	Bracket Dash STL LH
158	532 16 20-37	Bracket Parking Brake
159	532 18 13-55	Cupholder
161	532 16 46-55	Extrusion Bumper
206	532 17 01-65	Bolt Shoulder 5/16-18
209	817 00 06-12	Screw Hexwsh Thdr 3/8-16 x 3/4
278	532 19 16-11	Screw 10 x 3/4 Single Lead Hex

NOTE: All component dimensions given in U. S. inches
1 inch = 25.4 mm

REPAIR PARTS

TRACTOR - MODEL NO. LT2118A2 (96011012900), PRODUCT NO. 960 11 01-29
DRIVE

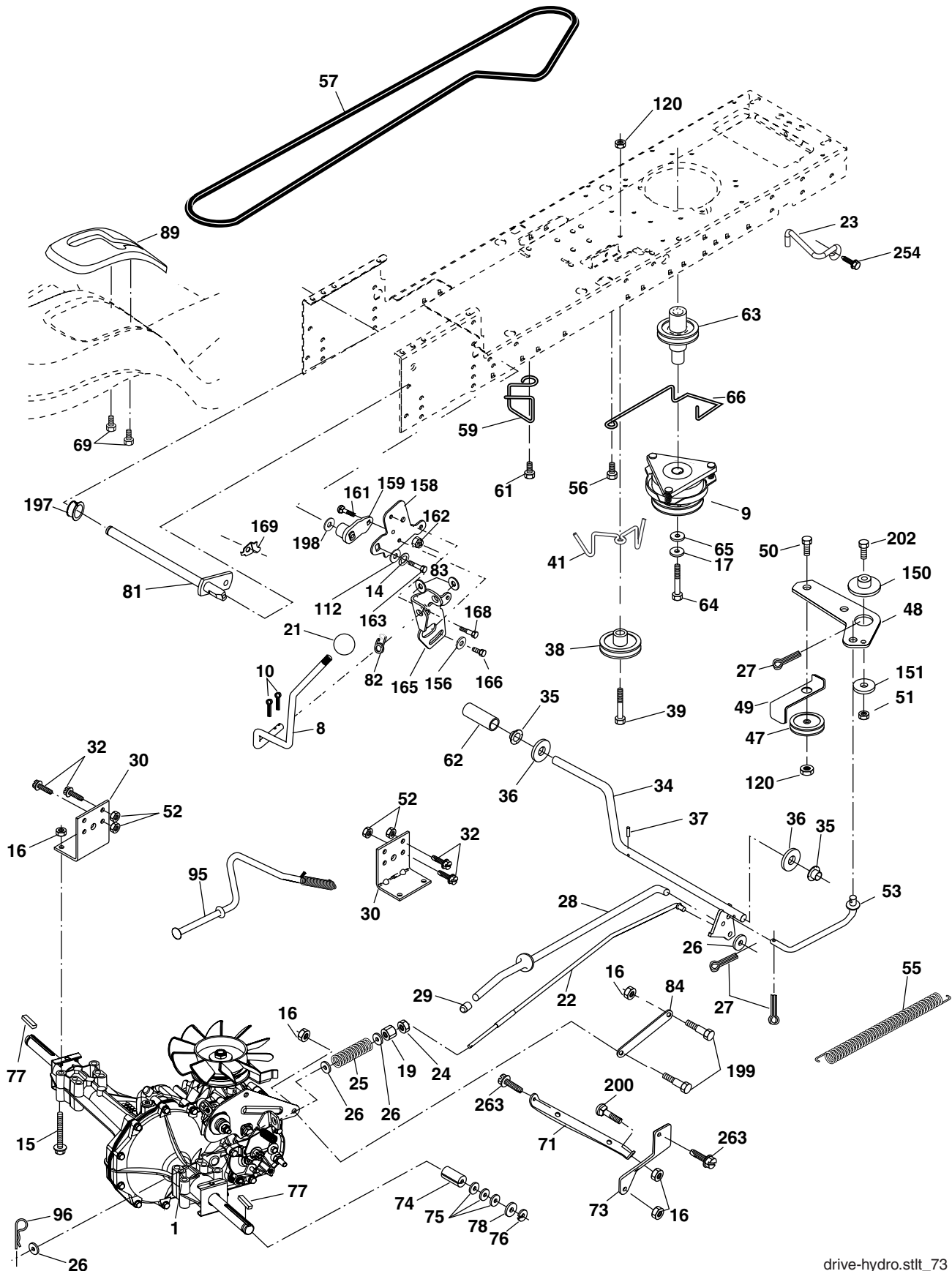

REPAIR PARTS

**TRACTOR - MODEL NO. LT2118A2 (96011012900), PRODUCT NO. 960 11 01-29
DRIVE**

KEY NO.	PART NO.	DESCRIPTION	KEY NO.	PART NO.	DESCRIPTION
1	-----	Transaxle Hydro Gear 314-0510 Order parts from transaxle manufacturer	64	532 17 39-37	Bolt, Hex 7/16-20 x 4 x Gr. 5-1.5
8	532 19 25-02	Rod Shift Fender	65	810 04 07-00	Washer
9	532 18 02-20	Clutch Electric	66	532 15 47-78	Keeper Belt Engine Hydro
10	876 02 04-16	Pin Cotter 1/8 x 1 CAD	69	532 14 24-32	Screw 1/4 x 1/2
14	810 04 04-00	Washer Lock Hvy Helical	71	532 16 91-83	Strap Torque Lh Hydro
15	874 49 05-44	Bolt Hex Flghd. 5/16-18 Gr.5	73	532 16 91-82	Strap Torque Rh Hydro
16	873 80 05-00	Nut Lock Hex W/Ins. 5/16-18 Unc P	74	532 13 70-57	Spacer, Axle
17	532 12 61-97	Washer 1-1/2 OD x 15/32 ID x .250	75	532 12 17-49	Washer 25/32 x 1-1/4 x 16 Ga.
19	873 80 06-00	Nut Lock Hex W/Wsh 3/8-16 Unc	76	812 00 00-01	E-Ring
21	532 13 05-64	Knob Deluxe	77	532 12 35-83	Key, Square
22	532 16 94-98	Rod, Brake Hydro	78	532 12 17-48	Washer 25/32 x 1-5/8 x 16 Ga.
23	532 19 07-36	Bracket Asm Anti Rot	81	532 16 55-96	Shaft Asm Cross Tapered 510 20"
24	873 35 06-00	Locknut	82	532 16 57-11	Spring Torsion T/A
25	532 10 68-88	Spring, Brake Rod	83	819 17 12-16	Washer 17/32 x 3/4 x 16 Ga.
26	819 13 13-16	Washer	84	532 16 95-94	Link Transaxle HB-0510
27	876 02 04-12	Pin Cotter 1/8 x 3/4 CAD.	89	532 19 57-46	Console, Shift
28	532 17 57-65	Rod, Parking Brake	95	532 17 02-01	Control Asm. Bypass Hydro
29	532 07 16-73	Cap, Parking Brake	96	532 12 47-88	Retainer Spring 1" Zinc/Cad
30	532 16 95-92	Bracket, Transaxle	112	819 09 12-10	Washer 9/32 x 3/4 x 10 Ga.
32	874 76 05-12	Bolt Hex Hd 5/16-18 Unc x 3/4	120	873 90 06-00	Nut Lock Flg 3/8-16
34	532 17 55-78	Shaft, Foot Pedal	150	532 17 54-56	Spacer Retainer
35	532 12 01-83	Bearing, Nylon	151	819 13 32-10	Washer 13/32 x 2 x 10 Ga.
36	819 21 16-16	Washer	156	532 16 60-02	Washer Srrted 5/16ID x 1.125
37	532 12 49-63	Pin, Roll	158	532 16 55-89	Bracket Shift Mount
38	532 17 91-14	Pulley, Composite, Flat	159	532 18 39-00	Hub Shift
39	872 11 06-22	Bolt RDHD 3/8-16 UNC x 2-3/4 Gr. 5	161	872 14 04-06	Bolt Rdhd Sqnk 1/4-20 x 3/4 Gr 5
41	532 17 55-56	Keeper, Belt Idler Flat	162	873 68 04-00	Nut Crownlock 1/4-20 Unc
47	532 12 77-83	Pulley, Idler, V-Groove	163	874 78 04-16	Bolt Hex Fin 1/4-20 Unc x 1 Gr 5
48	532 15 44-07	Bellcrank Grnd Clutch	165	532 16 56-23	Bracket Pivot Lever
49	532 12 32-05	Retainer, Belt	166	817 49 05-10	Screw 5/16-18 x 5/8
50	872 11 06-12	Bolt Carr. Sh. 3/8-16 x 1-1/2 Gr. 5	168	532 16 54-92	Bolt Shoulxder 5/16-18 x .561
51	873 68 06-00	Nut	169	532 16 55-80	Plate Fasteneing Lt
52	873 68 05-00	Nut Crown Lock 5/16-18	197	532 16 96-13	Nylinder Snap-In
53	532 19 96-52	Link, Clutch	198	532 16 95-93	Washer Nyl. 7/8 ID x .105"
55	532 10 57-09	Spring, Return, Clutch	199	532 16 96-12	Bolt Shoulder 5/16-18
56	817 06 06-20	Screw 3/8-16 x 1-1/4	200	872 14 05-08	Bolt Rdhd Sqnk 5/16-18 x 1
57	532 14 02-94	V-Belt, Ground Drive	202	872 11 06-14	Bolt Rdhd 3/8-16 x 1-3/4 Gr 5
59	532 16 96-91	Keeper, Center Span	254	817 00 06-16	Screw 3/8-16 x 1
61	817 12 06-14	Screw 3/8-16 x .875 SMGML Tap/R.Z	263	817 00 06-12	Screw Hex Wsh Thdr 3/8-16 x 3/4 BL
62	532 12 48-72	Cover, Pedal			
63	532 17 46-07	Pulley, Engine			

NOTE: All component dimensions given in U.S. inches
1 inch = 25.4 mm.

REPAIR PARTS

TRACTOR - MODEL NO. LT2118A2 (96011012900), PRODUCT NO. 960 11 01-29
STEERING ASSEMBLY

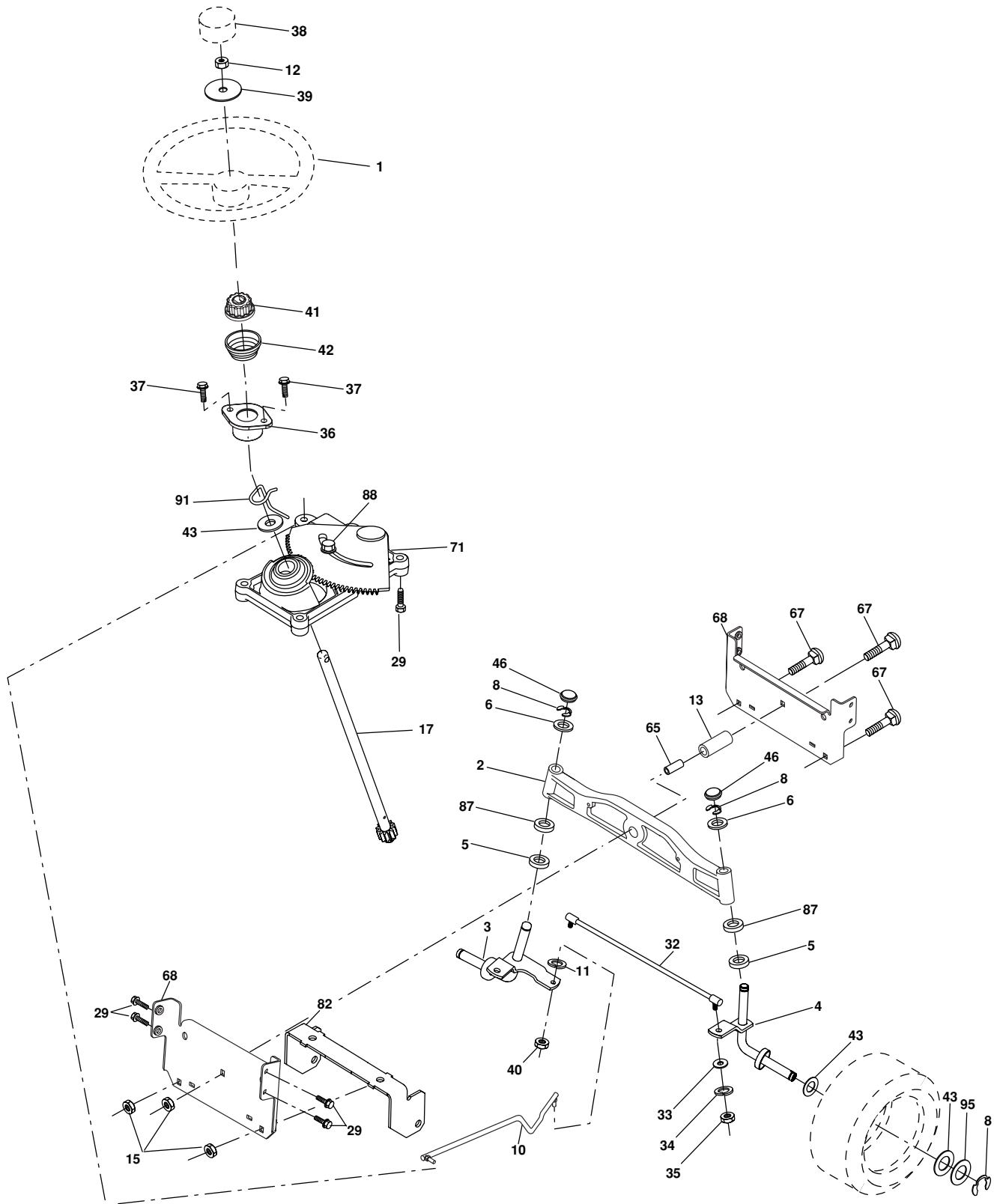

REPAIR PARTS

TRACTOR - MODEL NO. LT2118A2 (96011012900), PRODUCT NO. 960 11 01-29
STEERING ASSEMBLY

KEY NO.	PART NO.	DESCRIPTION
1	532 19 46-37	Wheel Steering
2	532 18 47-06	Axle Front Cast Iron
3	532 16 98-40	Spindle Asm LH
4	532 16 98-39	Spindle Asm Stmp RH
5	532 12 49-31	Bearing Race Thrust Harden
6	532 12 17-48	Washer 25/32 x 1-5/8 x 16 Ga
8	812 00 00-29	Ring Klip #t5304-75
10	532 17 51-21	Link Drag
11	810 04 06-00	Washer Lock Hvy Hlcl Spr 3/8
12	873 94 08-00	Nut Hex Jam Top Lock 1/2-20
13	532 13 65-18	Spacer Bearing Axle Front
15	532 14 52-12	Nut Hex Flange Lock
17	532 17 78-83	Shaft Asm Strg
29	817 00 06-12	Screw 3/8-16 x .75 SMGML
32	532 17 18-88	Rod Asm Tie Ball J Solid
33	819 11 12-16	Washer 11/32 x 3/4 x 16 Ga.
34	810 04 05-00	Washer Lock Hvy HLCL Spr. 5/16
35	873 54 05-00	Nut Crown Lock 5/16-24
36	532 15 51-05	Bushing Strg
37	532 15 29-27	Screw TT #32.5 x 5 x 3/8 Flange
38	532 19 46-03	Cap Wheel Steer
39	819 18 38-12	Washer 9/16 ID x 2-3/8 OD 12 Ga
40	873 54 06-00	Nut Crownlock 3/8-24
41	532 18 67-37	Adaptor Wheel Strg
42	532 17 71-49	Boot Dash Steering
43	532 12 17-49	Washer 25/32 x 1-1/4 x 16 Ga
46	532 12 12-32	Cap Spindle Fr Top Blk
65	532 16 03-67	Spacer
67	872 11 06-18	Bolt Rdhd Sqnk 3/8-16 x 2-1/4
68	532 16 98-27	Brace, Axle
71	532 17 51-46	Steering Asm
82	532 19 99-78	Bracket Susp Chassis
87	532 17 39-66	Washer Flat .781 x 1-1/2 x .14
88	532 17 51-18	Bolt Shoulder 7/16-20
91	532 17 55-53	Clip Steering
95	532 18 89-67	Washer Harden .793 x 1 .637 x 060

NOTE: All component dimensions given in U.S. inches
1 inch = 25.4 mm.

REPAIR PARTS

TRACTOR - MODEL NO. LT2118A2 (96011012900), PRODUCT NO. 960 11 01-29
ENGINE

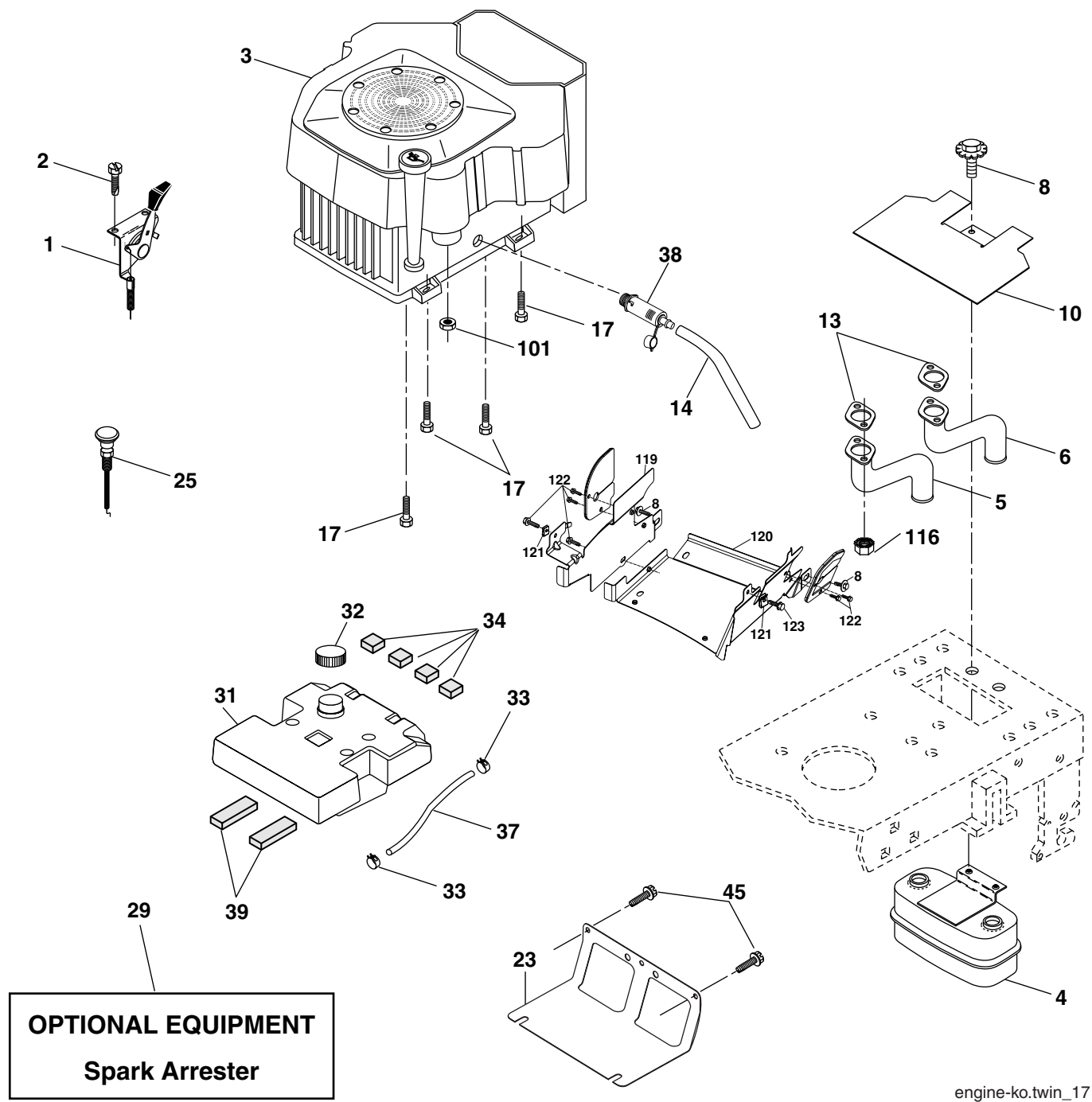

REPAIR PARTS

TRACTOR - MODEL NO. LT2118A2 (96011012900), PRODUCT NO. 960 11 01-29
ENGINE

KEY NO.	PART NO.	DESCRIPTION
1	532 17 81-47	Control Th/ch CB EEC. 428
2	532 19 16-11	Screw 10 x 3/4 Single Lead Hex
3	-----	Engine Kohl Model No. CV18S (Order parts from engine manufacturer)
4	532 14 97-23	Muffler Asm.
5	532 14 66-99	Pipe Exhaust LH
6	532 14 67-00	Pipe Exhaust RH
8	532 17 18-77	Bolt 5/16-18 Unc x 3/4 w/Sems
10	532 14 66-29	Shield Heat Muffler
13	-----	Gasket Eng (Order parts from engine manufacturer)
14	532 14 84-56	Tube Drain Oil Easy
17	817 06 06-24	Screw 3/8-16 x 1-1/2
23	532 16 98-37	Shield Browning/Debris Guard
25	532 18 95-41	Control Choke
29	532 13 71-80	Kit Spark Arrestor
31	532 15 71-03	Tank Fuel
32	532 14 05-27	Cap Asm Fuel Top Vented N/Lang
33	532 12 34-87	Clamp Hose Black
34	532 10 60-82	Pad Spacer 1 x 1 x 1
37	532 14 21-58	Line Fuel
38	532 18 16-54	Plug Drain Oil Easy
39	532 10 92-27	Pad Idler 1.75 x .75 x .06
45	817 00 06-12	Screw 3/8-16 x .75 SMGML
101	532 16 33-05	Nut Flange M8-1.25
116	532 18 43-62	Nut Hex Flange Toplock M8-1.25
119	532 40 05-94	Guard Asm. Engine RH
120	532 40 05-95	Guard Asm. Engine LH
121	532 19 66-88	Clip Threaded
122	532 13 77-29	Screw Thd Roll 1/4-20 x 5/8
123	817 67 05-08	Screw Thdrol. 5/16-18 x 1/2

NOTE: All component dimensions given in U.S. inches
1 inch = 25.4 mm

REPAIR PARTS

TRACTOR - MODEL NO. LT2118A2 (96011012900), PRODUCT NO. 960 11 01-29
MOWER DECK

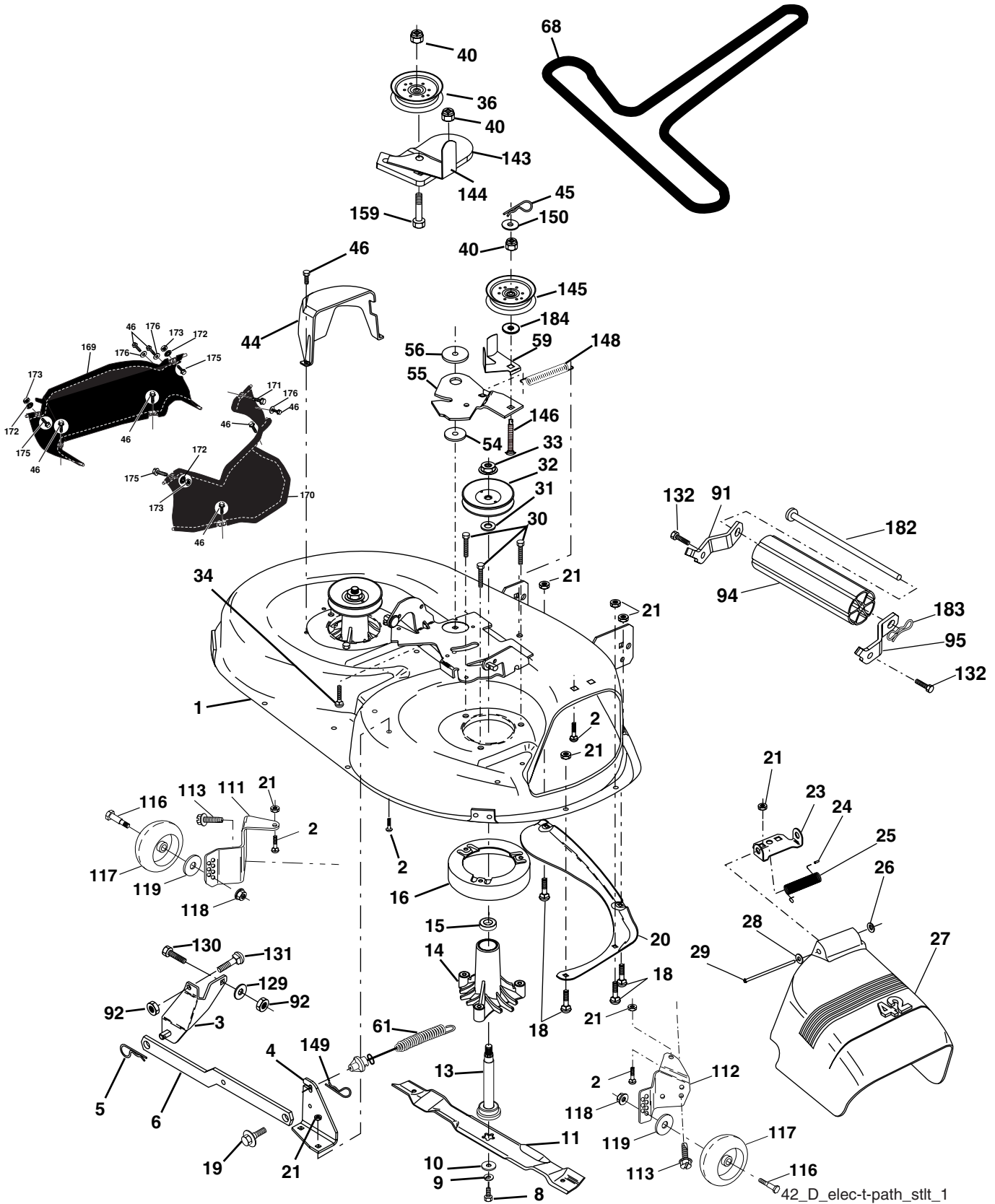

REPAIR PARTS

**TRACTOR - MODEL NO. LT2118A2 (96011012900), PRODUCT NO. 960 11 01-29
MOWER DECK**

KEY NO.	PART NO.	DESCRIPTION	KEY NO.	PART NO.	DESCRIPTION
1	532 16 58-92	Housing Asm Mower 42"94 T-Path	59	532 14 10-43	Guard, Belt
2	872 14 05-06	Bolt Rdhd Sqnk 5/16-18 Unc x 3/4	61	532 17 48-82	Spring Ext. Elect
3	532 13 80-17	Bracket Asm Fr Sway Bar 38/42	68	532 18 02-60	V-Belt Mower
4	532 16 54-60	Bracket Asm Deck 42"sway Bar	91	532 18 05-32	Bracket Asm Noseroller LH
5	532 12 46-70	Retainer Spring	92	873 80 06-00	Nut Lock Hex w/ins. 3/8-16 Unc
6	532 17 80-24	Bar Sway Deck	94	532 13 22-64	Roller Nose 38 & 42
8	532 85 08-57	Bolt 3/8-24 x 1 25 Gr8 Patched	95	532 18 05-33	Bracket Asm Noseroller RH
9	810 03 06-00	Washer Lock Hvy 3/8 Unplated	111	532 17 92-92	Bracket Gauge Wheel Lh
10	532 14 02-96	Washer Hard Blade Mower Vented	112	532 17 92-93	Bracket Gauge Wheel Rh
11	532 13 89-71	Blade Mower High Lift"	113	817 00 05-10	Bolt 5/16-18 Hex Whs. Hd. LCKSERR
13	532 13 76-45	Shaft Asm W/lower Bearing	116	532 12 48-42	Bolt Shoulder
14	532 12 87-74	Housing Mandrel Vented(machd)	117	532 18 86-06	Wheel Gauge
15	532 11 04-85	Bearing Ball Mandrel	118	873 93 06-00	Nut Centerlock 3/8-16 Unc
16	532 17 44-93	Stripper Mower	119	819 12 14-14	Washer 3/8 x 7/8 x 14 Ga.
18	872 14 05-05	Bolt Carr 5/16-18 x 5/8	129	819 13 13-12	Washer 13/32 x 13/16 x 12 Ga.
19	532 13 28-27	Bolt Shoulder	130	874 78 06-16	Bolt Fin Hex 3/8-16 Unc x 1 Gr. 5
20	532 15 97-70	Baffle Vortex 42	131	872 14 06-08	Bolt Rdhd Sqnk 3/8-16 Unc x1
21	873 68 05-00	Nut Crown Lock 5/16-18	132	817 00 06-12	Screw 3/8-16 x .75
23	532 17 75-63	Bracket Deflector Mower 42"	143	532 15 71-09	Bracket Arm Idler
24	532 10 53-04	Cap Sleeve 80x 112 Blk Mower	144	532 15 86-34	Keeper Belt
25	532 12 37-13	Spring Torsion Deflector 2 52	145	532 16 58-88	Pulley Idler Flat
26	532 11 04-52	Nut Push Phos & Oil	146	532 17 19-77	Bolt Carriage Idler
27	532 40 14-31	Shield Deflector	148	532 16 90-22	Spring Return Idler
28	819 11 10-16	Washer 11/32 x 5/8 x 16 Ga	149	532 16 58-98	Retainer Spring Yellow
29	532 13 14-91	Rod Hinge 42"6 75 Wlg	150	819 09 12-10	Washer 9/32 x 3/4 x 10
30	532 17 39-84	Screw Thd Rolling Hex	159	872 14 06-14	Bolt RDHD SQN 3/8-16 x 1-3/4
31	532 18 76-90	Washer Spacer	182	532 17 91-26	Rod Roller Nose Standard
32	532 15 35-35	Pulley Mandrel	183	532 19 42-09	Pin Cotter 7/16 Bowtie Lock
33	532 40 02-34	Nut Flange Lock Top	184	819 13 14-10	Washer 13/32 x 7/8 x 10 Ga.
34	872 11 06-12	Bolt Carr. Sh 3/8-16 x 1-1/2 Gr.5	199	532 40 02-78	Guard Asm. Fabric LH
36	532 13 14-94	Pulley Idler Flat 3 060	200	532 40 02-79	Guard Asm. Fabric RH
40	873 90 06-00	Nut Lock Flange 3/8-16 Unc	201	532 40 12-20	Push Nut Round 3/8 Diameter
44	532 14 00-88	Guard Mandrel LH Black	202	872 11 06-08	Bolt 3/8-16 x 1 Gr.5
45	532 12 47-88	Retainer Spring	203	532 19 72-62	Bolt Shoulder
46	532 13 77-29	Screw Thdrol 1/4-20 x 5/8	--	532 40 08-34	Replacement Deck, Complete
54	532 17 85-15	Washer Hardened	--	532 13 07-94	Mandrel Assembly (Includes Hous- ing, Shaft and Shaft Hardware Only - Pulley Not Included)
55	532 15 50-46	Arm Idler 42"mower LT/YT			
56	532 16 57-23	Spacer Retainer Mower			

NOTE: All component dimensions given in U.S. inches
1 inch = 25.4 mm

REPAIR PARTS

TRACTOR - MODEL NO. LT2118A2 (96011012900), PRODUCT NO. 960 11 01-29
MOWER LIFT

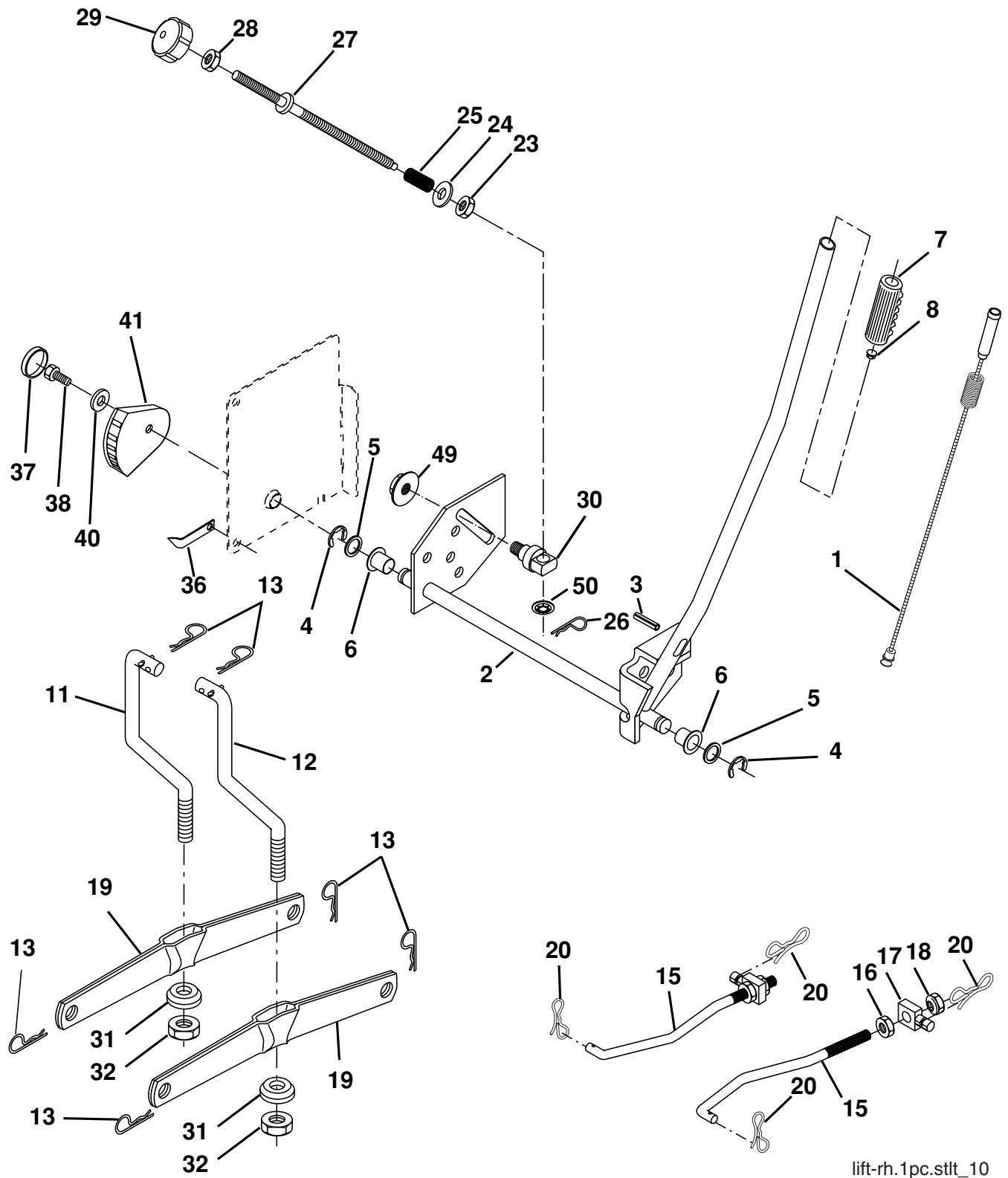

REPAIR PARTS

TRACTOR - MODEL NO. LT2118A2 (96011012900), PRODUCT NO. 960 11 01-29
MOWER LIFT

KEY NO.	PART NO.	DESCRIPTION
1	532 19 84-17	Wire Asm Inner/Sprg W/plunger LT
2	532 19 80-70	Shaft Asm Lift
3	532 18 88-22	Pin Groove
4	812 00 00-02	E Ring #5133-62
5	819 21 16-21	Washer 21/32 x 1 x 21 Ga.
6	532 12 01-83	Bearing Nylon Blk 629 Id
7	532 12 56-31	Grip Handle Fluted Blk
8	532 12 23-65	Button Plunger Red
11	532 13 98-65	Link Lift LH Mower
12	532 13 98-66	Link Lift RH Mower
13	532 12 46-70	Retainer Spring
15	532 17 32-88	Link Front
16	873 35 08-00	Nut Jam Hex 1/2-13 Unc
17	532 17 56-89	Trunnion Blk Zinc
18	873 80 08-00	Nut Lock W/wsh 1/2-13 Unc
19	532 13 98-68	Arm Suspension Rear
20	532 19 42-09	Pin Cotter 7/16 Bowtie Lock
23	532 11 08-07	Nut Special
24	819 13 10-16	Washer 13/32 x 5/8 x 16 Ga.
25	532 16 40-24	Spring Comp Infinite
26	532 16 94-84	Retainer Clip
27	532 16 45-43	Rod Adj Lift
28	873 35 06-00	Nut Hex Jam 3/8-16 Unc
29	532 13 80-57	Knob Inf 3/8-16 Unc
30	532 15 02-33	Trunnion Inf. Height
31	532 16 98-65	Bearing Put Lift
32	873 54 06-00	Nut Crownlock 3/8-24
36	532 15 50-97	Pointer Height Ind
37	532 12 39-35	Plug Hole
38	817 06 05-16	Screw 5/16-18 x 1 SMGML Tap/R
40	819 11 24-10	Washer 11/32 x 1-1/2 x 10 Ga.
41	532 15 50-98	Ind Height STLT
49	532 14 52-12	Nut, Hex Flange Lock
50	532 11 04-52	Nut Push Phos & Oil

NOTE: All component dimensions given in U.S. inches
1 inch = 25.4 mm

REPAIR PARTS

TRACTOR - MODEL NO. LT2118A2 (96011012900), PRODUCT NO. 960 11 01-29
SEAT ASSEMBLY

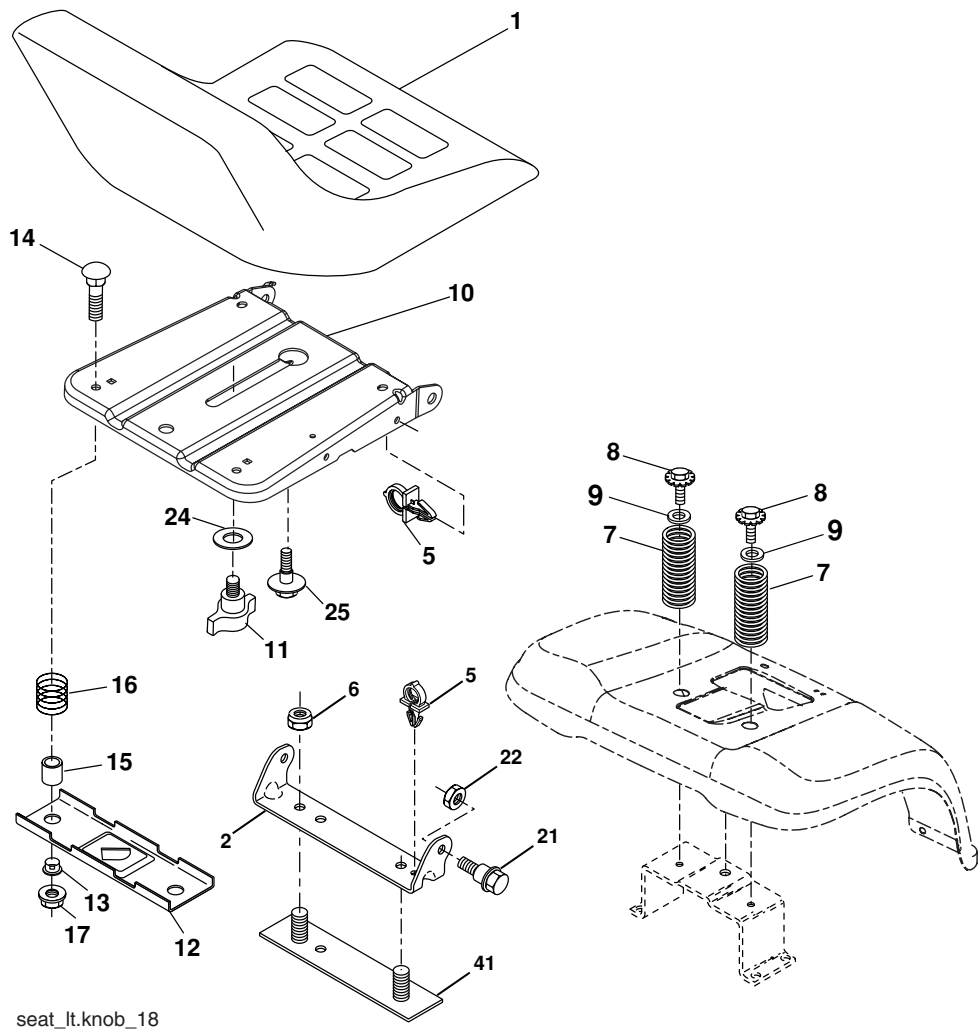

seat_lt.knob_18

KEY NO.	PART NO.	DESCRIPTION
1	532 40 10-43	Seat
2	532 14 05-51	Bracket Pivot
5	532 14 50-06	Clip Push-In Hinged
6	873 80 06-00	Nut Lock Hex w/Ins. 3/8-16 Unc
7	532 12 41-81	Spring Seat Cprsn 2 250 Blk Zi
8	817 00 06-16	Screw 3/8-16 x 1.5 SMGML
9	819 13 16-14	Washer 13/32 x 1 x 14 Ga
10	532 19 55-30	Pan Seat
11	532 16 63-69	Knob Seat Adj Wingnut
12	532 17 46-48	Bracket Mounting Switch
13	532 12 12-48	Bushing Snap Blk Nyl 50 Id

KEY NO.	PART NO.	DESCRIPTION
14	872 05 04-12	Bolt Rdhd Sht Nk 1/4-20 x 1-1/2
15	532 12 12-49	Spacer Split 28x 88 Zinc
16	532 12 37-40	Spring Cprsn 1 310 Blk Pnt
17	532 12 39-76	Nut Lock 1/4 Lge Flg Gr 5 Zinc
21	532 17 18-52	Bolt Shoulder 5/16-18 Unc-2A
22	873 80 05-00	Nut Lock 5/16-18
24	819 17 19-12	Washer 17/32 x 1-3/16 x 12 Ga
25	532 12 70-18	Bolt Shoulder 5/16-18 x .62
41	532 14 06-75	Strap Asm Fender

NOTE: All component dimensions given in U.S. inches
1 inch = 25.4 mm.