

# BP 2040C

## Operator's Manual



Please read these instructions carefully and make sure you understand them before using the machine.

# SYMBOL EXPLANATION

## Symbols



**WARNING!** Clearing saws, brushcutters and trimmers can be dangerous!  
Careless or incorrect use can result in serious or fatal injury to the operator or others.



Read through the Operator's Manual carefully and understand the content before using the machine.



Always use

- A protective helmet where there is a risk of falling objects
- Ear protection
- Approved eye protection



Max. speed of output axle, rpm



This product is in accordance with applicable EC directives.



Beware of thrown objects and ricochets.



The operator of the machine shall ensure, while working, that no persons or animals come closer than 15 metres.

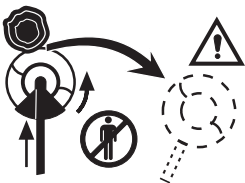

Machines fitted with clearing or grass blades can be thrown violently to the side when the blade comes into contact with a fixed object. The blade can cause the amputation of arms and legs. Always keep people and animals at least 15 metres from the machine.



Arrows which show limits for handle mounting.



Always wear approved protective gloves.



Use anti-slip and stable boots.



Only use non-metallic, flexible cutting elements, that is trimmer head with trimmer cord.



Noise emission to the environment according to the European Community's Directive. The machine's emission is specified in chapter Technical data and on label.

**Other symbols/decals on the machine refer to special certification requirements for certain markets.**

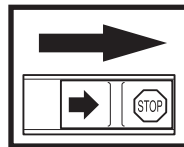

Checks and/or maintenance should be carried out with the engine switched off, with the stop switch in the STOP position.

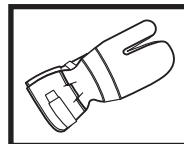

Always wear approved protective gloves.

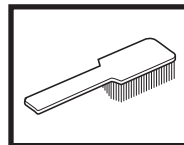

Regular cleaning required.

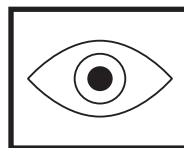

Ocular control.

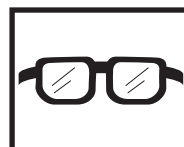

Approved eye protection must always be used.

# CONTENTS

Jonsered has a policy of continuous product development and therefore reserves the right to modify the design and appearance of products without prior notice.



**WARNING!**  
Under no circumstances may the design of the machine be modified without the permission of the manufacturer. Always use genuine accessories. Non-authorized modifications and/or accessories can result in serious personal injury or the death of the operator or others.

## List of contents

### SYMBOL EXPLANATION

Symbols ..... 2

### CONTENTS

List of contents ..... 3

### SAFETY INSTRUCTIONS

Personal protective equipment ..... 4

The machine's safety equipment ..... 4

Control, maintenance and service of the machine's safety equipment ..... 6

Cutting equipment ..... 8

General safety instructions ..... 9

General working instructions ..... 10

Adjusting the harness and clearing saw ..... 10

Basic clearing techniques ..... 11

### WHAT IS WHAT?

What is what on the grass trimmer/brushcutter? ..... 13

### ASSEMBLY

Assembling the J-handle and off-loading strap ..... 14

Transport position, J-handle ..... 14

Assembly of the blade and trimmer head ..... 14

Assembling the blade guard and grass blade ..... 14

Assembling the spray guard and trimmer head Auto 32 ..... 15

Assembling other guards and cutting equipment ..... 15

Assembling and dismantling the two-part shaft ..... 16

Adjusting the harness and clearing saw ..... 16

### FUEL HANDLING

Fuel mixture ..... 17

Fuelling ..... 17

### START AND STOP

Control before starting ..... 18

Start and stop ..... 18

### MAINTENANCE

Carburettor ..... 19

Muffler ..... 21

Cooling system ..... 21

Air filter ..... 21

Drive shaft ..... 22

Angle gear ..... 23

Two-part shaft ..... 23

Spark plug ..... 23

Filing the grass blade ..... 23

Maintenance schedule ..... 24

### TECHNICAL DATA

BP2040C ..... 26

# SAFETY INSTRUCTIONS

## Personal protective equipment

### IMPORTANT INFORMATION

- A clearing saw, brushcutter or trimmer used incorrectly or carelessly can become a dangerous tool, that can cause serious or fatal injury to the operator or others. It is extremely important that you read and understand the content of this manual.
- When using a clearing saw, brushcutter or trimmer, personal protective equipment approved by the appropriate authorities must be used. Personal protective equipment does not eliminate the risk of accidents, however, it can reduce the effects of an injury in the event of an accident. Ask your dealer for help when choosing protective equipment.



**WARNING!**  
Remove your hearing protection as soon as you stop the engine, so that you can hear any noises or warning signals.

### HELMET

A helmet should be worn if trees to be cleared are higher than 2 metres.



### EAR PROTECTION

Ear protection offering sufficient dampening effect should be used.

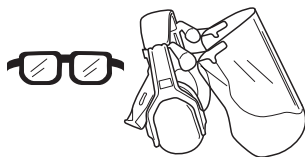

### EYE PROTECTION

Blows from branches or objects thrown by the rotating cutting equipment can damage the eyes.

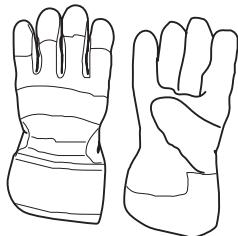

### GLOVES

Gloves should be worn when necessary, e.g., when assembling cutting equipment.

### BOOTS

Use anti-slip and stable boots.



### CLOTHING

Wear clothes made of a strong fabric and avoid loose clothing that can catch on shrubs and branches. Always wear heavy-duty long pants. Do not wear jewellery, shorts, sandals or go barefoot. Secure hair so it is above shoulder level.



### FIRST AID KIT

A first aid kit should be carried by operators of clearing saws, brushcutters or trimmers.

## The machine's safety equipment

This section describes the machine's safety equipment, its function and how checks and maintenance are carried out to ensure that it operates correctly. (See the chapter "What is what" to locate where this equipment is positioned on your machine.)



**WARNING!**  
Never use a machine with defective safety equipment. Follow the control, maintenance and service instructions described in this section.

### 1. Throttle trigger lock

The throttle trigger lock is designed to prevent the throttle from accidentally being engaged. When the trigger lock (A) is pressed into the handle (= when you hold the handle) the throttle (B) is released. When the grip on the handle is released the throttle and the throttle trigger lock return to their original positions. This takes place via two independent return spring systems. This means that the throttle is automatically locked in its "idling" position.

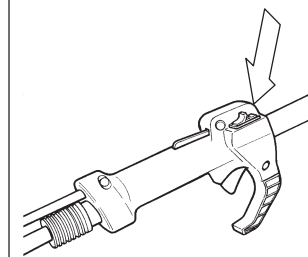
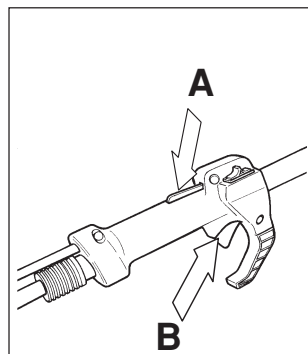

### 2. Stop switch

The stop switch should be used to stop the engine.

### 3. Cutting attachment guard

This guard is intended to prevent objects from being thrown towards the operator and to protect the operator from unintentional contact with the cutting attachment.

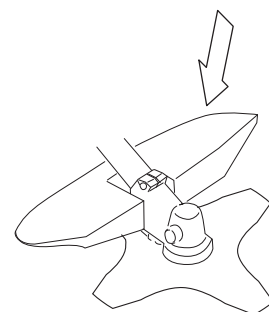

**WARNING!**  
Do not attach any blade to the unit without proper installation of all required parts. Failure to use the proper parts can cause the blade to fly off and seriously injure the operator and/or bystanders.

Under no circumstances may the cutting equipment be used without an approved guard fitted. See the chapter "Technical data". If the wrong guard or a defective guard is fitted this can cause serious personal injury.

# SAFETY INSTRUCTIONS

## 4. Vibration damping system

Your machine is equipped with a vibration damping system, which is designed to give as vibration-free and comfortable use as possible.

The use of blunt or incorrect cutting equipment (the wrong type or incorrectly sharpened, see the section “Sharpening the blade”) increases the level of vibration.

The machine’s vibration damping system reduces the transfer of vibrations between the engine unit/cutting equipment and the machine’s handle unit.

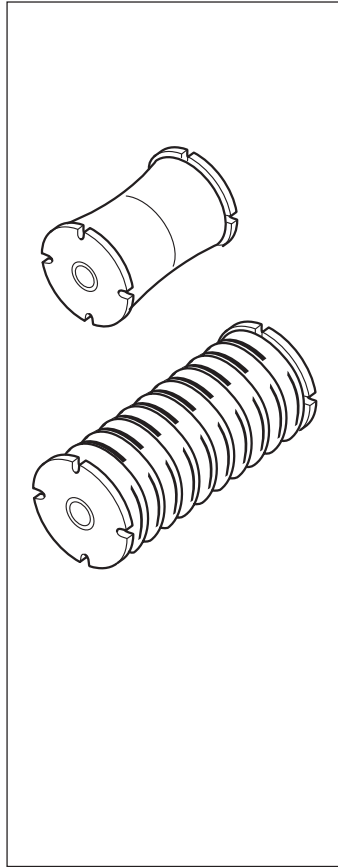

### WARNING!

Over exposure to vibrations can result in blood-vessel or nerve injury to persons suffering with blood circulation problems. Seek medical attention if you experience physical symptoms that can be related to over exposure to vibrations. Examples of such symptoms are “numbness”, lack of feeling, “tickling”, “pricking”, “pain”, lack of or a reduction in normal strength, changes in the colour of the skin or its surfaces. These symptoms normally appear in the fingers, hands or wrists.

## 5. Quick-release

There is an easily accessible, quick-release catch fitted to the chest as a safety precaution in the event of a fire in the engine or for any other situation that requires you to free yourself from the machine and harness. See the section “Adjusting the harness and clearing saw”.

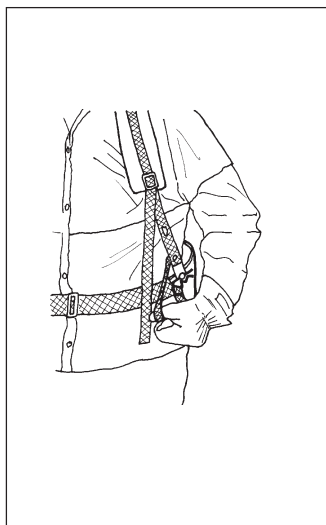

## 6. Muffler

The muffler is designed to give the lowest possible noise level and to direct the engine’s exhaust fumes away from the operator. Muffler fitted with catalytic converter is also designed to reduce harmful exhaust components.

In countries that have a warm and dry climate the risk of fire is obvious. We have therefore fitted certain mufflers with a spark arrest screen. Make sure that your muffler is fitted with this kind of screen.

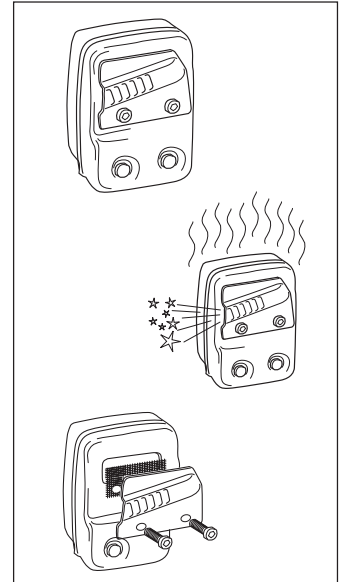

It is extremely important that the instructions for checking, maintaining and servicing the muffler are followed. (see the section “Control, maintenance and service of the machine’s safety equipment”).



### WARNING!

The exhaust fumes from the engine are hot and may contain sparks which can start a fire. Never start the machine indoors or near combustible material!



### WARNING!

Bear in mind that exhaust fumes:

- contain carbon monoxide, which can cause carbon monoxide poisoning. Therefore never start or run the machine indoors.
- are hot and can contain sparks that can cause fires. Never start the machine indoors or close to inflammable material.

## 7. Cutting equipment

1) Grass blades are intended for brush cutting.

2) The trimmer head is intended for trimming grass.

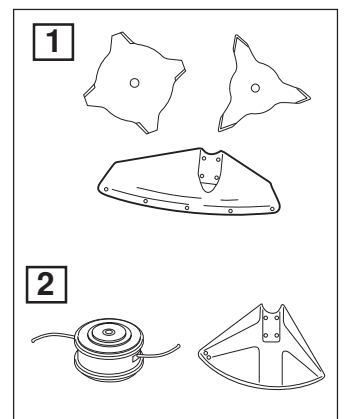

## 8. Locking nut

A locking nut is used to secure some types of cutting equipment on the output shaft.

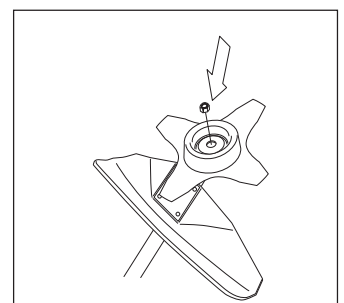

# SAFETY INSTRUCTIONS

## Control, maintenance and service of the machine's safety equipment

### IMPORTANT INFORMATION

- All service and repairs to the machine require special training.
- This applies especially to the machine's safety equipment. If the machine does not meet any of the controls listed below you should contact your service workshop.
- The purchase of one of our products guarantees that professional repair and servicing will be carried out on it. If the point of purchase is not one of our servicing dealers, please ask for details of the closest service workshop.

### 1. Throttle trigger lock

- Check that the throttle is locked in the "idling position" when the throttle trigger lock is in its original position.
- Press in the throttle trigger lock and make sure it returns to its original position when released.
- Ensure that the throttle and throttle trigger lock move easily and that their return spring systems function.
- See section "Start". Start the machine and apply full throttle. Release the throttle and check that the cutting equipment stops and remains at a standstill. If the cutting equipment rotates with the throttle in the idling position then the carburettor's idling setting must be checked. See chapter "Maintenance".

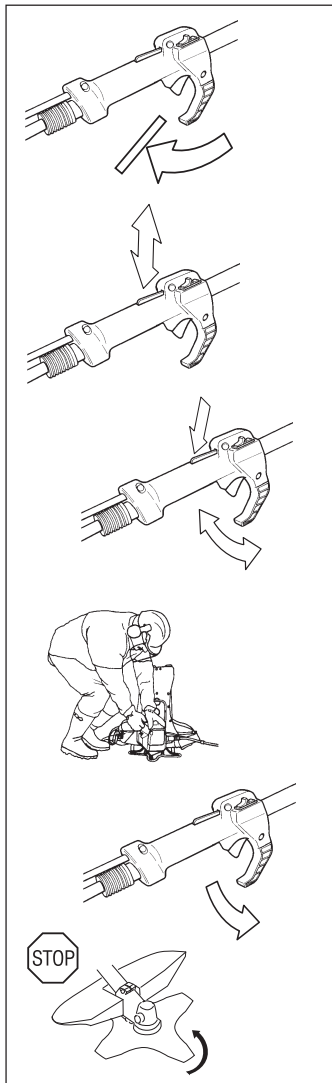

### 2. Stop switch

- Start the engine and make sure that the engine stops when the stop switch is moved to the stop position.

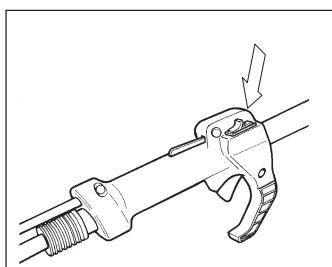

### 3. Cutting attachment guard

- Check that the guard is undamaged and not cracked.
- Replace the guard if it has been exposed to impact or is cracked.
- Always use the prescribed blade and guard combination, see chapter "Technical data".

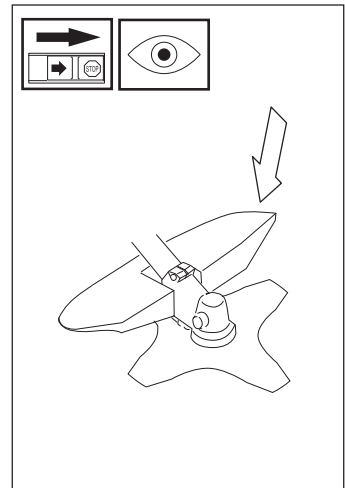

### 4. Vibration damping system

- Check the vibration damping element regularly for material cracks and distortion.
- Check that the vibration damping element is undamaged and securely attached.

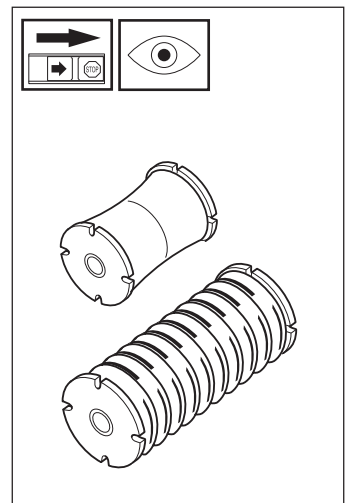

### 5. Muffler

1. Never use a machine that has a defective muffler.
2. Check regularly that the muffler is secure.
3. If your muffler is fitted with a spark arrest screen then it should be cleaned regularly. A blocked screen leads to the engine overheating with serious damage as a result. Never use a muffler with a defective spark arrest screen.

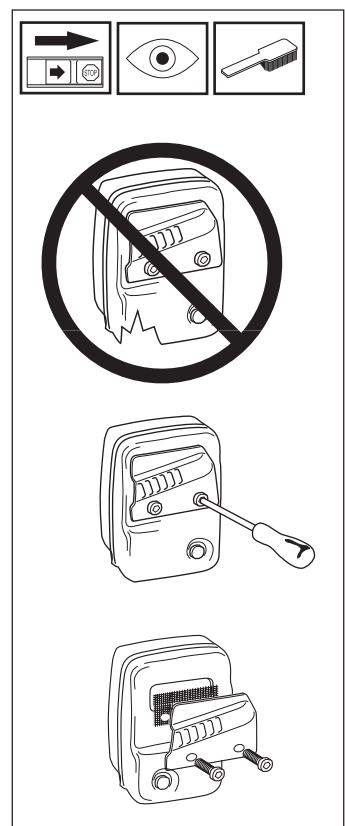



# SAFETY INSTRUCTIONS

## 6. Cutting equipment

This section describes how through correct maintenance and through using the right type of cutting equipment you can:

- Reduce the machine's tendency to kickback
- Obtain maximum cutting capacity.
- Increase the service life of the cutting equipment.

The three basic rules:

- 1) Only use the cutting and guard equipment we recommend! See chapter "Technical data".
- 2) Keep the blade's teeth well and correctly sharpened! Follow our instructions and use the recommended filing gauge. An incorrectly sharpened or damaged blade increases the risk of an accident.
- 3) Check the cutting equipment with regard to damage and crack formation. Damaged cutting equipment should always be replaced.

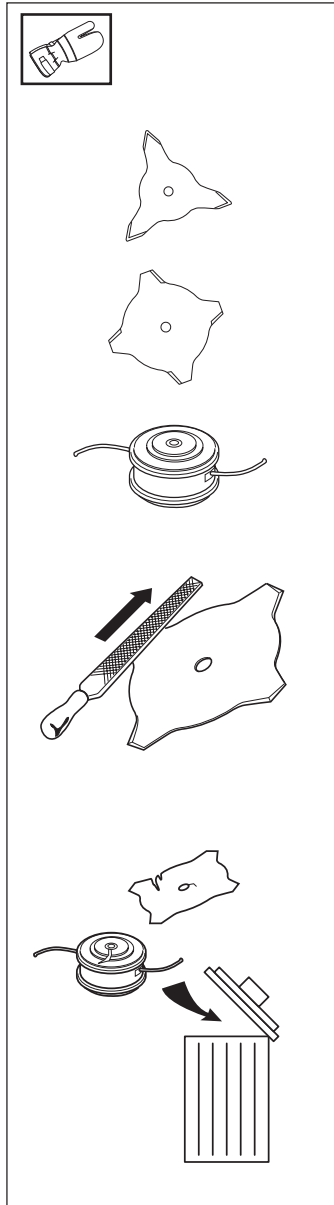

## 7. Quick-release

- Check that the harness straps are correctly positioned. When the harness and machine are adjusted, check the harness' safety release catch to ensure it works correctly.

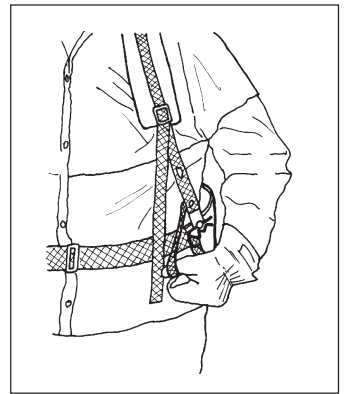

## 8. Locking nut

- Protect your hand from injury when assembling, use the blade guard as protection when tightening with a socket spanner. Tighten the nut by turning against the direction of rotation. Loosen the nut by turning in the direction of rotation. (NOTE! the nut has a left-hand thread).
- Tighten the nut using a socket spanner, 35 - 50 Nm (3.5 - 5 kpm).

### NOTE!

The locking nut's nylon lock must not be so worn that it can be turned by hand. The lock shall hold at least 1.5 Nm. The nut should be replaced after it has been put on approx. 10 times.

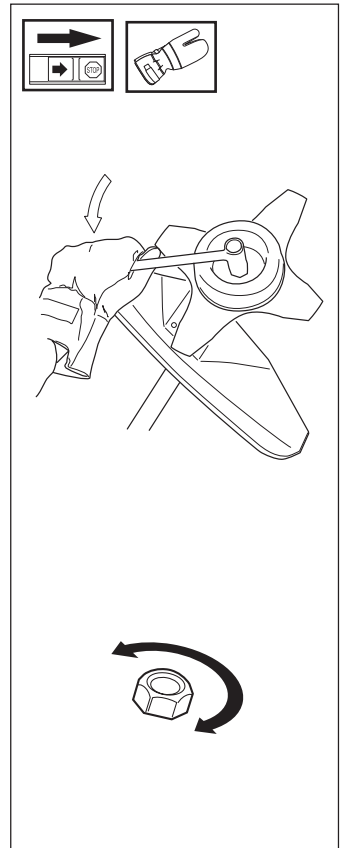

### WARNING!

Never use a machine with defective safety equipment. The safety equipment should be maintained as described in this section. If your machine does not meet any of these controls you should contact your service workshop.

# SAFETY INSTRUCTIONS

## Cutting equipment

### IMPORTANT INFORMATION

The section describes how through correct maintenance and through using the right type of cutting equipment you can reduce the machine's tendency to kickback, obtain maximum clearing capacity and increase the service life of the cutting equipment.

- Only use the cutting and guard equipment we recommend! See chapter "Technical data".
- Refer to the instructions for the cutting equipment for the correct winding of cord and for the selection of the right cord diameter.
- Keep the blade's teeth well and correctly sharpened! Follow our recommendations. Also refer to the instructions on the blade packaging.



**WARNING!**  
Incorrect cutting equipment or an incorrectly sharpened blade increases the risk of kickback.

## Filing the grass blade

- See the cutting equipment's packaging for correct filing instructions.
- The blades are sharpened using a single cut flat file.
- Sharpen all edges equally to maintain the balance of the blade.

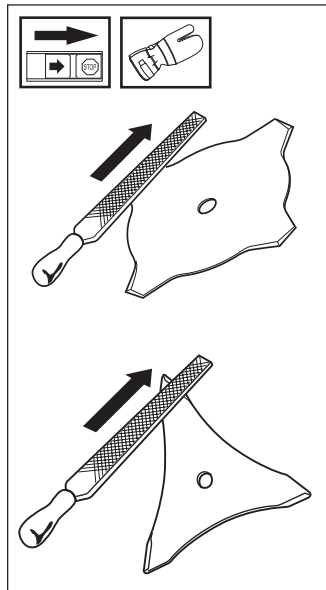

## Trimmer head

- Only use a trimmer head and trimmer cord that is recommended. These have been tested by the manufacturer to suit a particular engine size. This is especially important when a fully automatic trimmer head is used. Only use the cutting equipment we recommend! See chapter "Technical data".

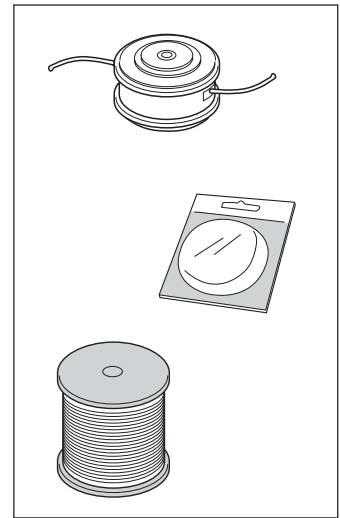

- Generally smaller machines require a small trimmer head and vice versa. This is because when clearing using a cord the engine must throw out the cord radially from the trimmer head and also meet resistance from the grass being cleared.
- The length of the cord is also important. A longer cord requires greater engine power than a shorter cord of the same diameter.
- Make sure the knife positioned on the trimmer guard is intact. This is used to cut the cord to the correct length.
- To increase the life of the cord it can be soaked in water for a few days. This will make the line tougher and it will keep longer.

### IMPORTANT INFORMATION

Always ensure the trimmer cord is wound tightly and evenly around the drum, otherwise harmful vibrations will occur.



**WARNING!**  
Always stop the engine before starting work on any part of the cutting equipment. This continues to rotate even after the throttle has been released. Ensure that the cutting equipment has stopped completely and remove the cable from the spark plug before you start to work on it.



# SAFETY INSTRUCTIONS

## General safety instructions

### IMPORTANT INFORMATION

- The machine is only designed for trimming grass and brush cutting.
- The only accessories to be used with the engine unit as a drive source are the cutting units we recommend in the chapter "Technical data".
- Never use the machine if you are tired, if you have consumed alcohol, or if you are taking medicines that can affect your sight, your judgement or the control of your body.
- Use personal protective equipment. See the section "Personal protective equipment".
- Never use a machine that has been modified so that it no longer corresponds with the original design.
- Never use a machine that is faulty. Follow the maintenance, control and service instructions in this Operator's Manual. Some maintenance and service actions should be carried out by trained and qualified specialists. See the chapter "Maintenance".
- All covers and guards must be fitted before starting the machine. Check that the spark plug cap and HT lead are not damaged, otherwise you could get an electric shock.
- The machine operator shall ensure, while working, that no persons or animals come closer than 15 metres. When several operators are working in the same area the safety distance should be at least double tree length, however, at least 15 metres.



**WARNING!**  
Faulty cutting equipment or an incorrectly sharpened blade increases the risk of accidents.

## Start



**WARNING!**  
When the engine is started with the choke in either the choke or start throttle positions the cutting equipment starts to rotate immediately.

- The complete clutch cover with shaft must be fitted before the machine is started, otherwise the clutch can become loose and cause personal injury.
- Never start the machine indoors. Bear in mind the dangers of inhaling the engine's exhaust fumes.
- Observe your surroundings and make sure that there is no risk of people or animals coming into contact with the cutting equipment.
- Place the machine on the ground, ensure the cutting equipment runs free of twigs and stones. Push the machine body towards the ground using your left hand. (NOTE! Not with your foot). Grip the starter handle with your right hand and pull the starter cord.

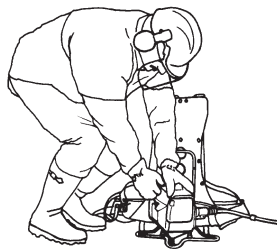

## Fuel safety

- Always use a fuel container with an anti-spill valve.
- Never fill the machine while the engine is running. Always stop the engine and let it cool for a few minutes before refuelling.
- Provide good ventilation when filling or mixing fuel (petrol and 2-stroke oil).
- Move the machine at least 3 m from the filling position before starting.
- Never start the machine:
  - a) If you have spilt fuel on it. Wipe up all spillage.
  - b) If you have spilt fuel on yourself or your clothes. Change your clothes.
  - c) If there is a fuel leak. Make regular checks for leakage from the fuel cap and the fuel supply pipes.



Min 3 m  
(10ft)

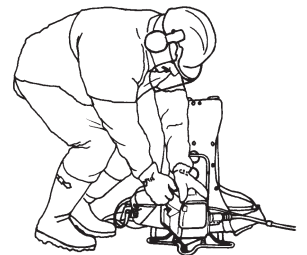

## Transport and storage

- Store and transport the machine and fuel so that any leakage or fumes do not risk coming into contact with sparks or naked flames. For example, electric machines, electric motors, electrical switches/power switches, heaters or the like.
- When storing and transporting fuel approved containers intended for this purpose must be used.
- When storing the machine for long periods the fuel tank must be emptied. Contact your local petrol station to find out how to dispose of excess fuel.
- Always keep the transport guard attached when transporting and storing the machine.



**WARNING!**  
Exercise great care when handling fuel. Bear in mind the risk of fire, explosions and inhaling fumes.

# SAFETY INSTRUCTIONS

## General working instructions

### IMPORTANT INFORMATION

- This section takes up the basic safety precautions for working with the clearing saw and trimmer.
- If you encounter a situation where you are uncertain how to proceed you should ask an expert. Contact your dealer or your service workshop.
- Avoid all usage which you consider to be beyond your capability.
- Before starting you must understand the difference between forestry clearing, brush cutting and grass trimming.

## Basic safety precautions

1. Observe your surroundings:
  - To ensure that people, animals or other things cannot affect your control of the machine.
  - To ensure that the above mentioned do not come into contact with the cutting equipment or objects that can be thrown by the cutting equipment.
  - **NOTE!** Never use a machine without the possibility of calling for help in the event of an accident.
2. Avoid usage in unfavourable weather conditions. For example, thick fog, heavy rain, strong winds or extreme cold, etc. To work in bad weather conditions is tiring and can create dangerous situations, for example, slippery surfaces.
3. Make sure you can walk and stand safely. Look out for any obstacles with unexpected movement (roots, stones, branches, pits, ditches, etc.). Take great care when working on sloping ground.
4. The engine should be switched off before moving. When moving over longer distances and transporting the transport guard should be used.
5. Never put the machine down with the engine running unless you have good sight of it.



## Adjusting the harness and clearing saw



### WARNING!

When working with the clearing saw the harness should always be worn. If this is not done, you cannot control the clearing saw safely and this can result in injury to yourself or someone else. Never use a harness with a defective quick release catch.

### Quick release

On the front is an easily accessible, quick release catch:

- Pull out the red strap.
- The hip strap and one shoulder strap will be automatically released at the same time and the harness and the engine unit will slide to the ground.

Use this if the engine should catch fire or in any other emergency situation when you quickly need to take off the harness and machine.

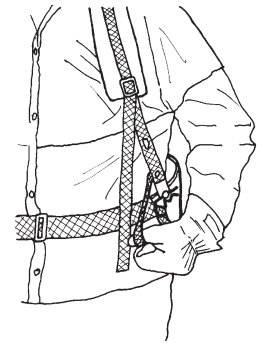

### Equal load on shoulders

A well matched saw and harness make work much easier. Adjust the harness to give the best working stance. Adjust the side straps so that the weight is equally divided across the shoulders.



### Off-loading strap

The off-loading strap is intended to off-load the weight from the shaft. Adjust the length of the strap so that the cutting equipment balances just above the ground.



# SAFETY INSTRUCTIONS

## Basic clearing techniques

- Always carry out clearing and trimming at full throttle.
- Always drop to idling speed after each working operation. Longer periods running at full throttle without loading the engine (that is without resistance, which the engine feels from the cutting equipment when trimming) can lead to serious engine damage.

## Designations

- Brush cutting is a general term for clearing grass. Grass blades are used for this purpose.

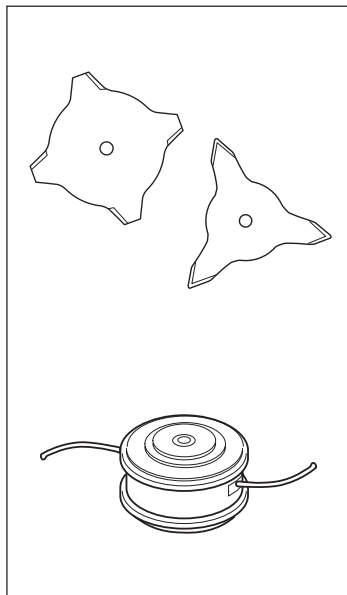

- Grass trimming is a general term for light clearing, e.g. around edges or around trees. A trimmer head or plastic blade is used.



**WARNING!**  
Sometimes grass can collect in the spray guard and cutting head. Always stop the engine when cleaning.

## Brush cutting using a grass blade

- A blade is used for all types of high or thick grass.
- The grass is cut down with a sideways, swinging movement, where the movement from right-to-left is the clearing stroke and the movement from left-to-right is the return stroke. Let the blade work on the left-hand side (between 8 and 12 o'clock).

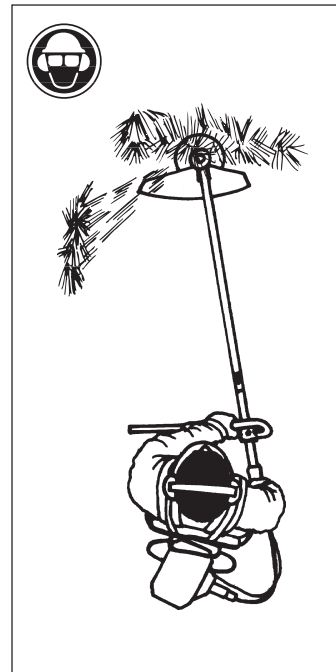

- If the blade is angled to the left when clearing the grass will collect in a line, which makes collection easier, e.g. when raking.
- Try to work rhythmically. Stand firmly with your feet apart. Move forward after the return stroke and stand firmly again.
- Let the support cup rest lightly against the ground. It is used to protect the blade from hitting the ground.
- Reduce the risk of material wrapping around the blade by following these instructions:
  - a) Always work at full throttle.
  - b) Avoid the previously cut material during the return stroke.
- Stop the engine, loosen the harness and place the machine on the ground before you start to collect the cut material.



**WARNING!**  
Neither the user of the tool or anyone else may attempt to remove the cut material while the engine is running or with the blade rotating as this can result in serious injury. Stop the engine and blade before you remove material that has wound around the blade as otherwise there is a risk of injury. The bevel gear unit can get hot during use and may remain so for a while afterwards. There is a risk of slight burns if you touch it.



**WARNING!**  
Warning for thrown objects. Always wear protective glasses. Never lean over the guard. Stones, rubbish, etc. can be thrown up into the eyes causing blindness or serious injury. Keep unauthorised persons at a distance. Children, animals, onlookers and helpers should be kept outside the safety zone of 15 m. Stop the machine immediately if anyone approaches.

# SAFETY INSTRUCTIONS

## Grass trimming using the trimmer head and plastic blades

- Hold the trimmer head just above the ground at an angle. It is the end of the cord that carries out the work. Let the cord work at its own pace. Do not press the cord into the area to be cut.
- The cord can easily remove grass and weeds up against walls, fences, trees and borders, however, it can also damage sensitive bark on trees and bushes and damage fence posts.
- Reduce the risk of damaging plants by shortening the cord to 10-12 cm and reducing the engine speed.

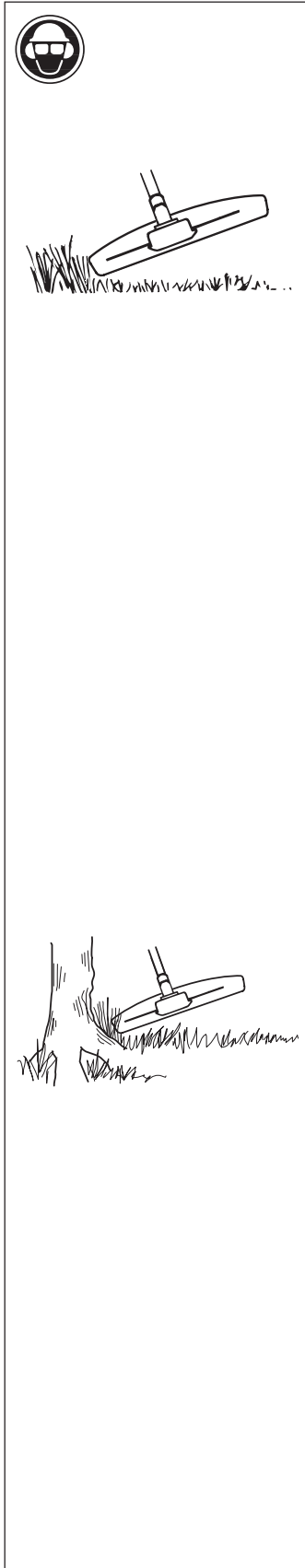

## Clearing

- The clearing technique removes all unwanted vegetation. Keep the trimmer head just above the ground and tilt it. Let the end of the cord strike the ground around trees, posts, statues and the like. **NOTE!** This technique increases the wear on the cord.
- The cord wears quicker and must be fed forward more often when working against stones, brick, concrete, metal fences, etc. than when coming into contact with trees and wooden fences.
- When trimming and clearing you should use less than full throttle so that the cord lasts longer and to reduce the wear on the trimmer head.

## Trimming

- The trimmer is ideal to cut grass that is difficult to reach using a normal lawn mower. Keep the cord parallel to the ground when cutting. Avoid pressing the trimmer head against the ground as this can ruin the lawn and damage the tool.
- Do not allow the trimmer head to constantly come into contact with the ground during normal cutting procedures. Constant contact can cause damage and wear to the trimmer head.

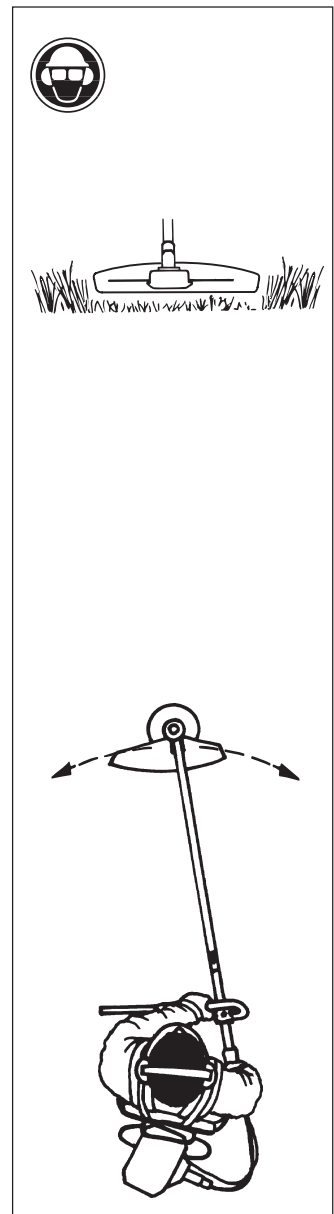

## Sweeping

- The rotating cord's fanning effect can be used for quick and easy cleaning. Hold the cord parallel to and above the area to be swept and move the trimmer from side to side.
- When cutting and sweeping you should use full throttle to obtain the best results.



### WARNING!

**Warning for thrown objects. Always wear protective glasses. Never lean over the guard. Stones, rubbish, etc. can be thrown up into the eyes causing blindness or serious injury. Keep unauthorised persons at a distance. Children, animals, onlookers and helpers should be kept outside the safety zone of 15 m. Stop the machine immediately if anyone approaches.**

# WHAT IS WHAT?

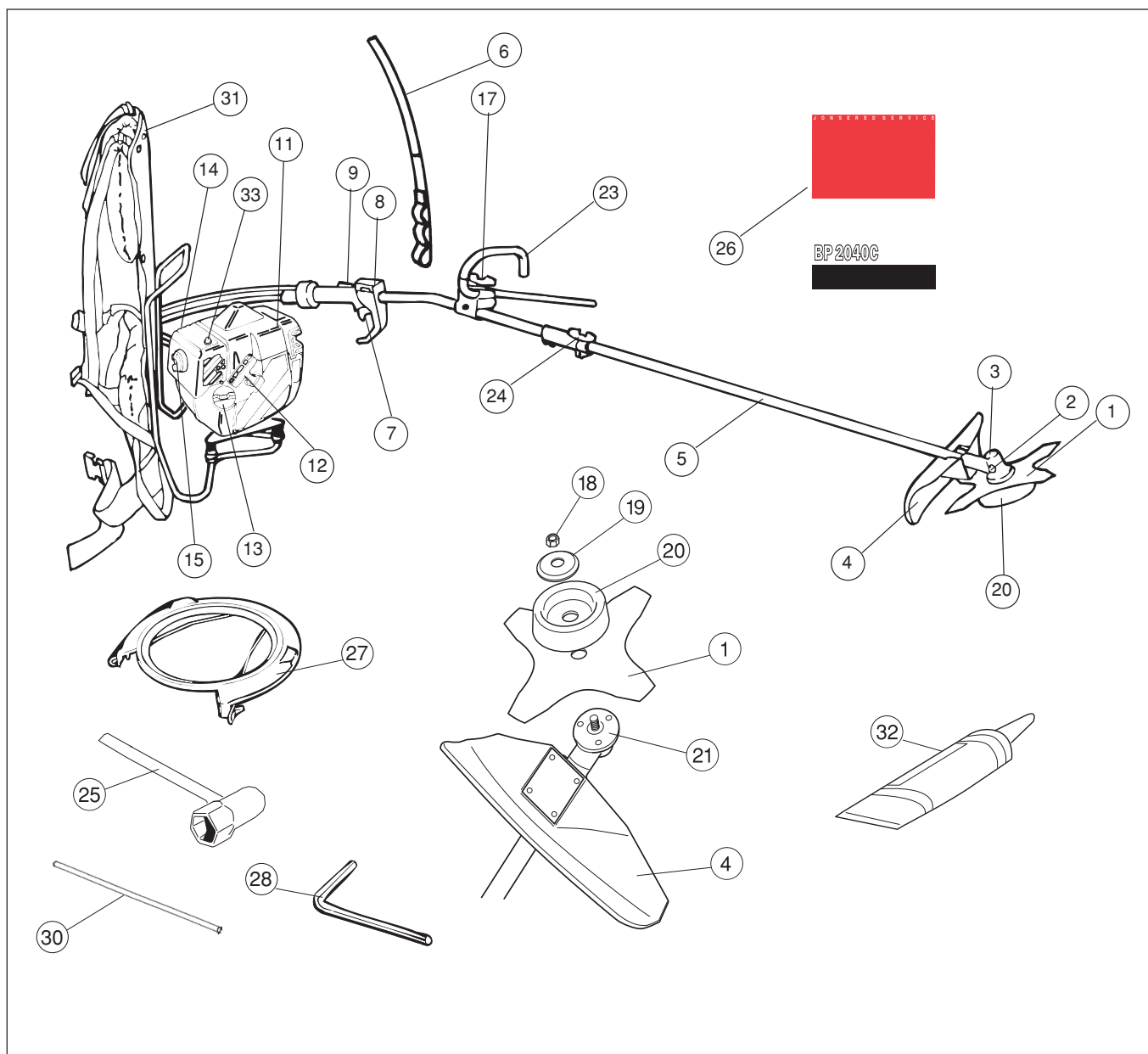

## What is what on the grass trimmer/brushcutter?

- |     |                       |     |                    |
|-----|-----------------------|-----|--------------------|
| 1.  | Blade                 | 18. | Locking nut        |
| 2.  | Grease filler cap     | 19. | Support flange     |
| 3.  | Angle gear            | 20. | Support cup        |
| 4.  | Spray guard           | 21. | Drive disc         |
| 5.  | Shaft                 | 23. | J-handle           |
| 6.  | Off-loading strap     | 24. | Shaft coupling     |
| 7.  | Throttle              | 25. | Socket spanner     |
| 8.  | Stop switch           | 26. | Operator's Manual  |
| 9.  | Throttle trigger lock | 27. | Transport guard    |
| 11. | Cylinder cover        | 28. | Allen key          |
| 12. | Starter handle        | 30. | Locking pin        |
| 13. | Fuel tank             | 31. | Harness            |
| 14. | Choke                 | 32. | Drive shaft grease |
| 15. | Air filter cover      | 33. | Air purge          |
| 17. | Handlebar adjustment  |     |                    |



# ASSEMBLY

## Assembling the J-handle and off-loading strap



**WARNING**  
Only grass blades or trimmer heads/  
plastic blades may be used when the J-  
handle is fitted. Clearing blades must  
never be used with the J-handle.

- Loosen the knob from the handle bracket.
- Position the handle as shown. Fit the bracket components and tighten the handle lightly.
- Fit the off-loading strap around the shaft as shown.
- Put on the harness and secure the off-loading on the right-hand side strap. Adjust the length so that the cutting equipment balances just above the ground.
- Finely adjust the J-handle to give a comfortable working stance. Tighten the knob.

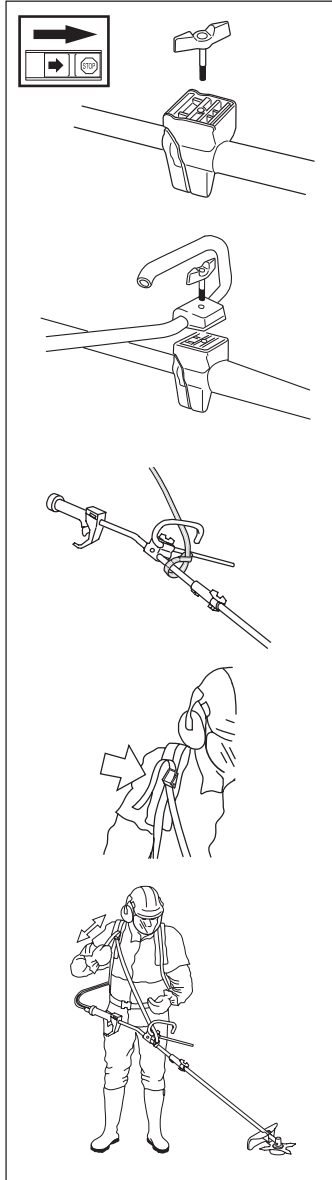

## Transport position, J-handle

- The handlebars can easily be turned to fit along the shaft for easy transportation and storage.
- Loosen the knob. Turn the J-handle clockwise.
- Thereafter fold the handlebars around the shaft. Tighten the handle.
- Attach the transport guard.

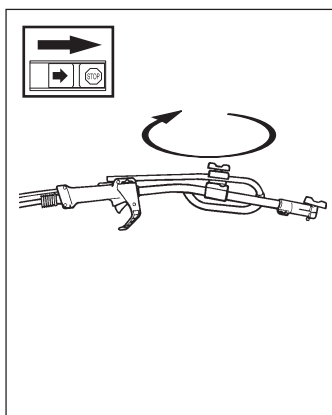

## Assembly of the blade and trimmer head

It is extremely important that the disc drive's/support flange's guide engages correctly in the cutting equipment's centre hole when assembling the cutting equipment. Cutting equipment assembled incorrectly can result in serious and/or fatal personal injury.

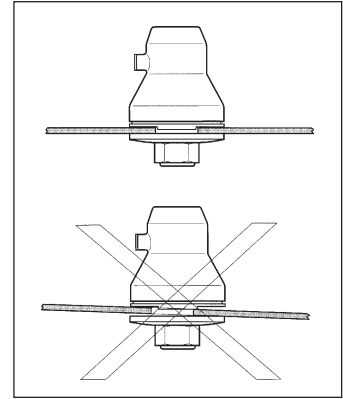

**WARNING!**  
Do not attach any blade to the unit without proper installation of all required parts. Failure to use the proper parts can cause the blade to fly off and seriously injure the operator and/or bystanders.

Under no circumstances may the cutting equipment be used without an approved guard fitted. See the chapter "Technical data". If the wrong guard or a defective guard is fitted this can cause serious personal injury.

## Assembling the blade guard and grass blade

- The guard (A) is fitted using 4 screws (L) and the support plate (M) as set out in the diagram.  
NOTE! Use the recommended blade guard.
- Fit the drive disc (B) on the output shaft.
- Turn the blade shaft until one of the holes in the drive disc aligns with the hole in the gear housing.
- Insert the locking pin (C) in the hole so that the shaft is locked.
- Place the blade (D), support cup (E) and support flange (F) on the output shaft.
- Fit the nut (G). The tightening torque of the nut is 35-50 Nm (3,5 - 5 kpm). Use the socket spanner in the tool kit. Hold the handle of the spanner as close to the blade guard as possible. The nut is tightened when the spanner is turned against the direction of rotation (left-hand thread).

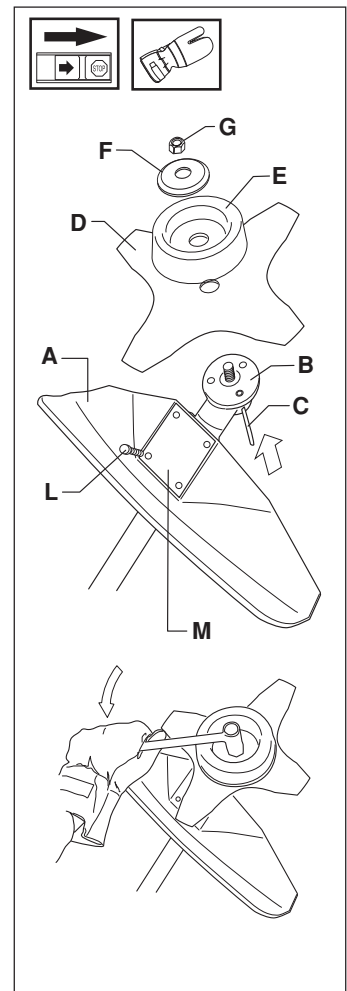



# ASSEMBLY

## Assembling the spray guard and trimmer head Auto 32

- Fit the guard (A) intended for use with the trimmer head. Secure using the 4 bolts (L) and the support plate (M) as set out in the diagram.
- Fit the drive disc (B) on the output shaft.
- Turn the blade shaft until one of the holes in the drive disc aligns with the hole in the gear housing.
- Insert the locking pin (C) in the hole so that the shaft is locked.
- The trimmer head must be split to be fitted (see the diagram). Proceed as follows:
  - Insert your finger into the centre hole of the cover (I) at the same time as you hold the cover with your other fingers. Press the two catches (J) that extend from the cut-out on the bottom section (K) using the thumb and index finger of your other hand. Press apart the trimmer head using the fingers on the cover.
- Place the cover (I) and the support flange (F) on the output shaft.
- Fit the nut (G). The tightening torque of the nut is 35-50 Nm (3,5-5 kpm). Use the socket spanner in the tool kit.

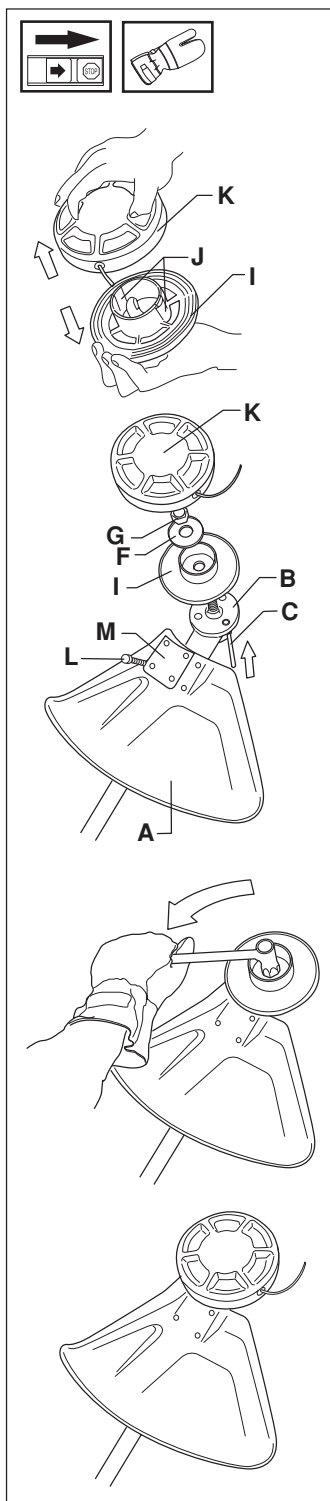

Hold the handle of the spanner as close to the trimmer guard as possible. The nut is tightened when the spanner is turned against the direction of rotation (left-hand thread).

- Fit the trimmer head's bottom section (K) on the cover (I) by pressing the two sections together with the cut-outs on the bottom section aligned with the catches on the cover.
- To dismantle follow the instructions in the reverse order.

## Assembling other guards and cutting equipment

- Fit the guard (A) intended for use with the trimmer head. Secure using four bolts (L) and the support plate (M) as shown in the diagram.
- Fit the disc drive (B) on the output shaft.
- Turn the blade shaft until one of the disc drive's holes aligns with the corresponding hole in the gear housing.
- Insert the locking pin (C) into the hole to lock the shaft.
- Screw on the trimmer head (H) in the direction of rotation.
- Dismantling takes place in the reverse order.

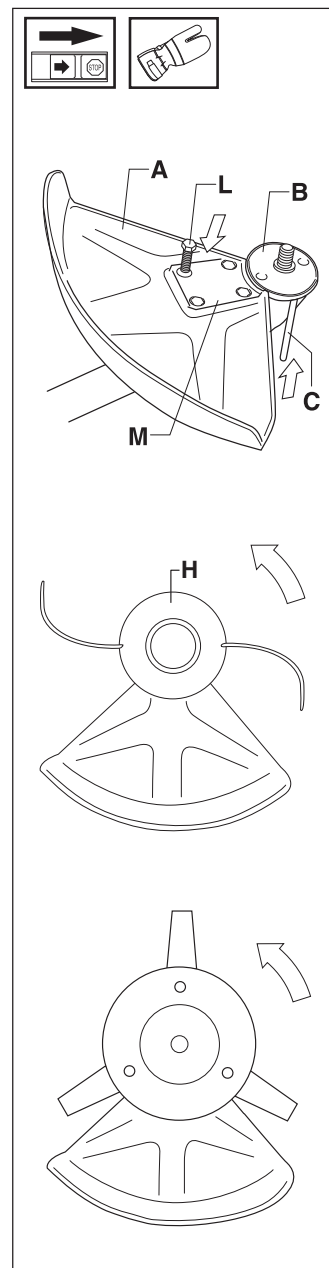

# ASSEMBLY

## Assembling and dismantling the two-part shaft

### Assembling:

- Make sure the handle is loose.
- Guide the cut-out on the lower section of the shaft into the coupling's locking plate on the upper section of the shaft. The sections are then locked together.
- Tighten the handle.

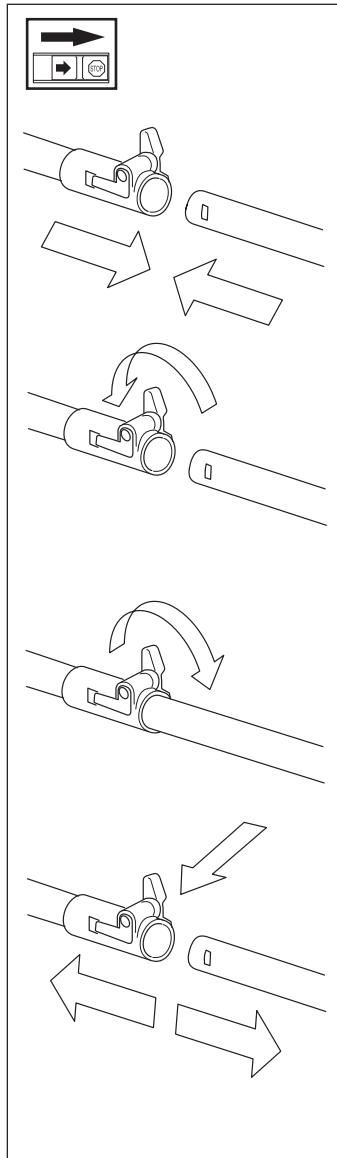

### Dismantling

- Undo the handle (at least three turns).
- Press the handle towards the coupling.
- Carefully twist the lower section out of the lock.
- Hold both parts of the shaft and pull out the lower section from the coupling.

## Adjusting the harness and clearing saw



### WARNING!

When working with the clearing saw the harness should always be worn. If this is not done, you cannot control the clearing saw safely and this can result in injury to yourself or someone else. Never use a harness with a defective quick release catch.

### Quick release

On the front is an easily accessible, quick release catch:

- Pull out the red strap.
- The hip strap and one shoulder strap will be automatically released at the same time and the harness and the engine unit will slide to the ground.

Use this if the engine should catch fire or in any other emergency situation when you quickly need to take off the harness and machine.

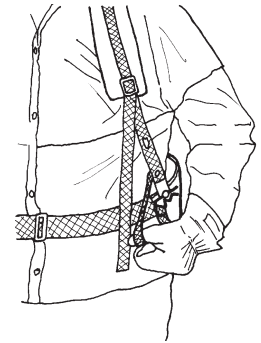

### Equal load on shoulders

A well matched saw and harness make work much easier. Adjust the harness to give the best working stance. Adjust the side straps so that the weight is equally divided across the shoulders.



### Off-loading strap

The off-loading strap is intended to off-load the weight from the shaft. Adjust the length of the strap so that the cutting equipment balances just above the ground.



# FUEL HANDLING

## Fuel

### NOTE!

The machine is fitted with a two-stroke engine and must always be run on a mixture of petrol and two-stroke oil. It is important to measure the quantity of oil accurately, to ensure the correct mixture ratio. Small discrepancies in the amount of oil have a great bearing on the proportions of the fuel mixture when mixing small amounts of fuel.



**WARNING!**  
Always provide good ventilation when handling fuel.

## Petrol

### NOTE!

Always use an oil-mixed quality petrol (at least 90 octane). If your machine is equipped with a catalytic converter, (see "technical data") an unleaded, oil mixed quality petrol should always be used. A leaded petrol will destroy the catalytic converter.

- The lowest recommended octane rating is 90. If you run the engine on a petrol with a lower octane rating than 90 so-called "knocking" can occur. This leads to an increased engine temperature, which can result in a serious engine breakdown.
- When working at continuous high revs a higher octane rating is recommended.

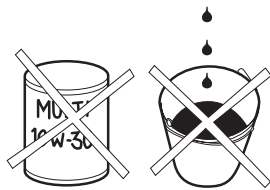
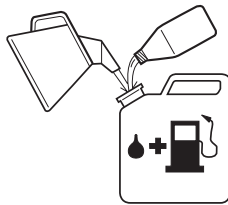

## Two-stroke oil

- For the best results use JONSERED two-stroke oil, which has been specially produced for clearing saws and chain saws. Mixing ratio 1:50 (2%).
- If JONSERED two-stroke oil is not available you can use a high quality two-stroke oil intended for air cooled engines. Contact your dealer when selecting an oil. Mixing ratio: 1:33 (3%).
- Never use two-stroke oil intended for water cooled outboard motors, so-called outboard motor oil.
- Never use oil intended of four-stroke engines.

## Mixture

- Always mix petrol and oil in a clean container intended for petrol.
- Always start by filling half the quantity of petrol required. Then add the entire oil quantity. Mix (shake) the fuel mixture. Fill the remaining quantity of petrol.
- Mix (shake) the fuel mixture carefully before filling in the machine's fuel tank.
- Do not mix more than max. one month's supply of fuel.
- If the clearing saw is not used for a long period of time, the fuel tank should be emptied and cleaned.



**WARNING!**  
The catalytic converter muffler gets very hot during and after use. This also applies during idling. Be aware of the fire hazard, especially when handling the saw near flammable substances or vapours.

## Fuelling



**WARNING!**  
The following precautions reduce the risk of fire:  
Do not smoke or place any sources of heat in the vicinity of the fuel. Never refuel when the engine is running. Always stop the engine and let it cool for a few minutes before refuelling. Open the fuel cap slowly when fuelling so that any over pressure is released slowly. Tighten the fuel cap carefully after refuelling. Always move the machine from the fuelling place before starting.

- Clean around the fuel cap. Contamination in the tank can disrupt operations.
- Ensure that the fuel is well mixed by shaking the container before filling the tank.



Min. 3 m  
(10 ft)

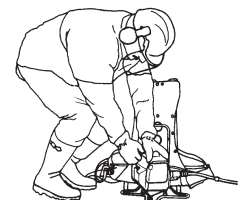
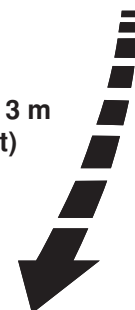

Gasolin Benzin Esence Gasolina Lit.	Oil • Öl Huile • Aceite Lit.	
	2% (1:50)	3% (1:33)
5	0,10	0,15
10	0,20	0,30
15	0,30	0,45
20	0,40	0,60
US gallon	US fl. oz.	
	2% (1:50)	3% (1:33)
1	2 1/2	3 3/4
2 1/2	6 1/2	9 3/4
5	12 7/8	19 1/4

# START AND STOP

## Control before starting

For reasons of safety follow these recommendations!

- Check the blade to ensure that no cracks have formed at the bottom of the teeth or by the centre hole. The most common reason why cracks are formed is that sharp corners have been formed at the bottom of the teeth while sharpening or that the blade has been used with dull teeth. Discard a blade if cracks are found.
- Check that the support flange is not cracked due to fatigue or due to being tightened too much. Discard the support flange if it is cracked.
- Ensure the locking nut has not lost its captive force. The nut lock should have a locking force of at least 1.5 Nm. The tightening torque of the locking nut should be 35-50 Nm.
- Check that the guard is not damaged or cracked. Replace the guard if it is exposed to impact or is cracked.
- Check that the trimmer head and spray guard are not damaged or cracked. Replace the trimmer head or spray guard if they are exposed to impact or are cracked.
- Never use the machine without a guard or spray guard nor with a defective guard.

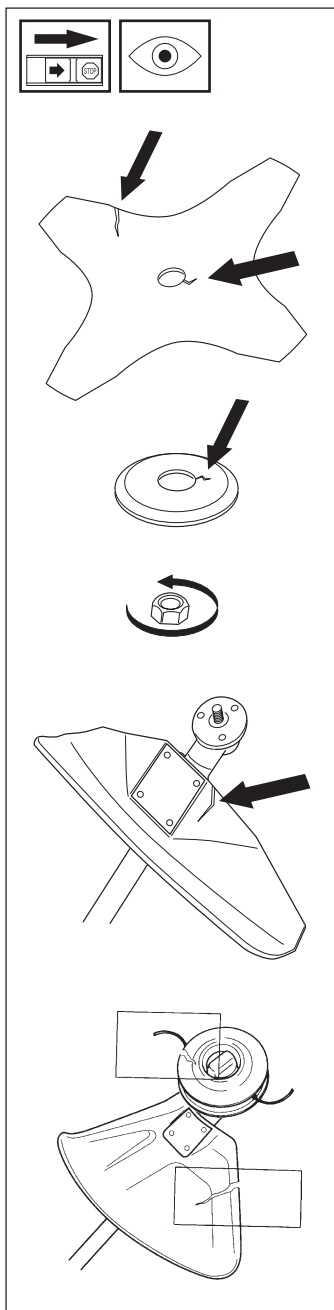

## Start and stop



**WARNING!**  
The complete clutch cover with shaft must be fitted before the machine is started, otherwise the clutch can become loose and cause personal injury. Always move the machine from the filling area before starting. Place the machine on a flat surface. Ensure the cutting equipment cannot come into contact with any object. Make sure no unauthorised persons are in the working area, otherwise there is a risk of serious personal injury. The safety distance is 15 metres.

### Cold engine

**IGNITION:** Set the stop switch to the start position.  
**CHOKE:** Set the choke control in the choke position.

**AIR PURGE:**  
Press the air purge diaphragm repeatedly until fuel begins to fill the diaphragm. The diaphragm need not be completely filled.

### Warm engine

Use the same starting procedure as for the cold engine, but do not set the choke control in the choke position. The start throttle position is obtained by setting the choke control in the choke position and then returning it to its original position.

### Stop

The engine is stopped by switching off the ignition.

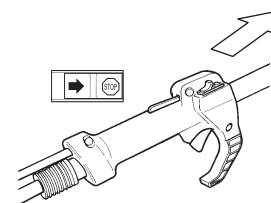
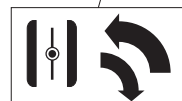
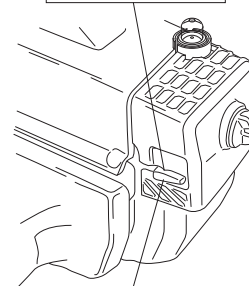
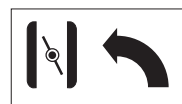

**WARNING!**  
When the engine is started with the choke in the choke or start position the cutting equipment starts to rotate immediately.

### Start

Press the machine body against the ground using your left hand (NOTE! Not your foot). Grip the starter handle, slowly pull out the cord with your right hand until you feel some resistance (the starter pawls grip), now quickly and powerfully pull the cord. Reset the choke control as soon as the engine fires and repeat until the engine starts. When the engine starts quickly apply full throttle and the start throttle will automatically disengage.

**NOTE!** Do not pull the starter cord out completely and do not release the starter cord from the fully extended position. This can damage the machine.

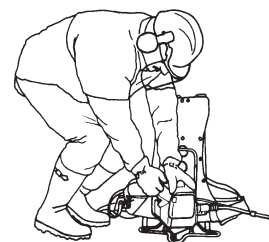

# MAINTENANCE

## Carburettor

Your JONSERED product has been designed and manufactured to specifications that reduce harmful emissions. After your unit has been run 8-10 tanks of fuel the engine has broken in. To ensure that your unit is at peak performance and producing the least amount of harmful emissions after break in, have your authorized servicing dealer, who has a revolution counter at his disposal, to adjust your carburettor for optimum operating conditions.



**WARNING!**  
The complete clutch cover with shaft must be fitted before the machine is started, otherwise the clutch can become loose and cause personal injury.

## Operation

- The carburettor governs the engine's speed via the throttle. Air/fuel is mixed in the carburettor. The air/fuel mixture is adjustable. To take advantage of the engine's optimal output the adjustment must be correct.
- The setting of the carburettor means that the engine is adapted to local conditions, for example, the climate, altitude, petrol and the type of 2-stroke oil.
- The carburettor is equipped with three adjustment possibilities:  
L = Low speed needle  
H = High speed needle  
T = Idle speed adjuster screw
- The fuel quantity in relation to the air flow permitted by the throttle opening is adjusted using the L and H-needles. Turning the needles clockwise gives a leaner fuel mixture (less fuel) and turning them anti-clockwise gives a richer fuel mixture (more fuel). A leaner mixture gives high revs while a richer mixture give less revs.
- The T-screw regulates the position of the throttle while the engine is idling. Turning the screw clockwise gives a higher idling speed while turning it anti-clockwise gives a lower idling speed.

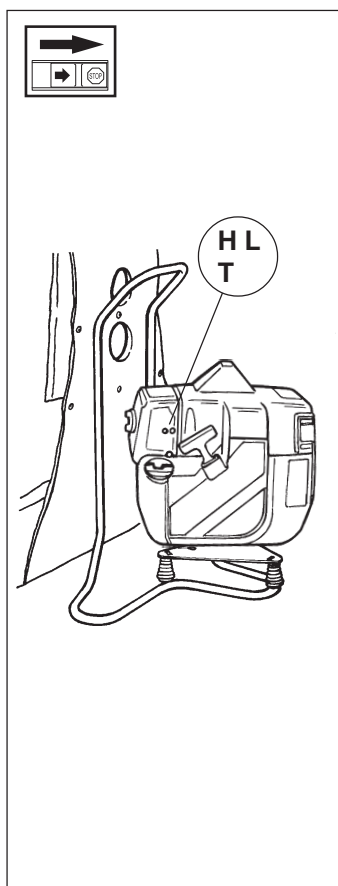

## Basic setting

- The carburettor is set to its basic setting when test run at the factory. The basic setting is richer than the optimal setting and should be kept during the machine's first working hours. Thereafter the carburettor should be finely adjusted. Fine adjustment should be carried out by a skilled technician.

**NOTE!** If the cutting attachment rotates/moves while the engine is idling the T-screw should be turned anti-clockwise until the cutting attachment stops.

**Rec. idling speed: 2 700 rpm.**

**Recommended max. speed: see "technical data".**



**WARNING!**  
If the idling speed cannot be adjusted so that the cutting attachment stops, contact your service workshop. Do not use the machine until it has been correctly adjusted or repaired.

## Fine adjustment

- When the machine has been "run-in" the carburettor should be finely adjusted. **The fine adjustment should be carried out by qualified person.** First adjust the L-jet, then the idling screw T and then the H-jet.

## Conditions

- Before any adjustments are made the airfilter should be clean and the airfilter cover fitted. Adjusting the carburettor while a dirty airfilter is in use will result in a leaner mixture when the filter is finally cleaned. This can give rise to serious engine damage.
- Carefully turn the L and H needle to the mid point between fully turned in and fully turned out.
- **Do not attempt to adjust the needles beyond the stops as damage can occur.**
- Now start the machine according to the starting instructions and run it warm for 10 minutes.

**NOTE!** If the cutting attachment rotates/moves the T screw should be turned anti-clockwise until the cutting attachment stops.

## Low speed needle L

Try to find the highest idling speed, turning the low speed needle L clockwise respectively counter-clockwise. When the highest speed has been found, turn the low speed needle L 1/4 turn counter-clockwise.

**NOTE!** If the cutting attachment rotates/moves in the idling position, turn the idling speed screw T counter-clockwise until the cutting attachment stops.

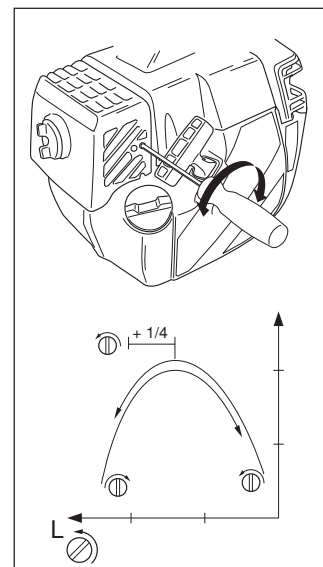



# MAINTENANCE

## Final setting of the idling speed T

Adjust the idling speed with the screw T, if it is necessary to readjust. First turn the idle speed adjusting screw T clockwise until the cutting attachment starts to rotate/move.

Then turn, counter-clockwise until the cutting attachment stops. A correctly adjusted idle speed setting occurs when the engine runs smoothly in every position. It should also be good margin to the rpm when the cutting attachment starts to rotate/move.

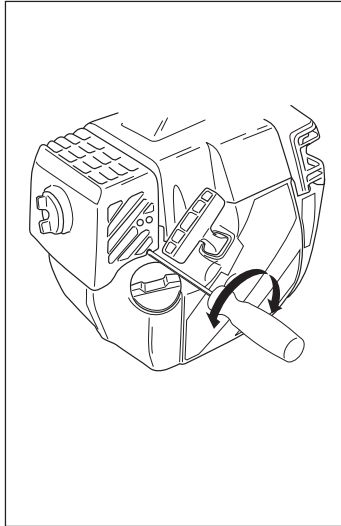

**CAUTION!** Contact your servicing dealer, if the idle speed setting cannot be adjusted so that the cutting attachment stops. Do not use the machine until it has been properly adjusted or repaired.

## High speed needle H

The high speed needle affects the machine's power, speed, temperature and fuel consumption. A too lean adjustment on the high speed needle H (the high speed needle H is screwed in too much) gives a too high speed resulting in engine damage. Do not allow the engine to run at full speed for more than 10 seconds. Apply full throttle and turn the high speed needle H slowly anticlockwise until the engine runs unevenly. The high speed needle H is then turned slowly clockwise a little until the engine runs smoothly. Note the engine should be run unloaded when adjusting the high speed needle. Therefore dismantle the cutting equipment, nut, support flange and disc drive before adjusting the high speed needle. The high speed needle is adjusted correctly when the machine 'splatters' a little. If the machine smokes heavily at the same time as it 'splatters' heavily the adjustment is too rich.

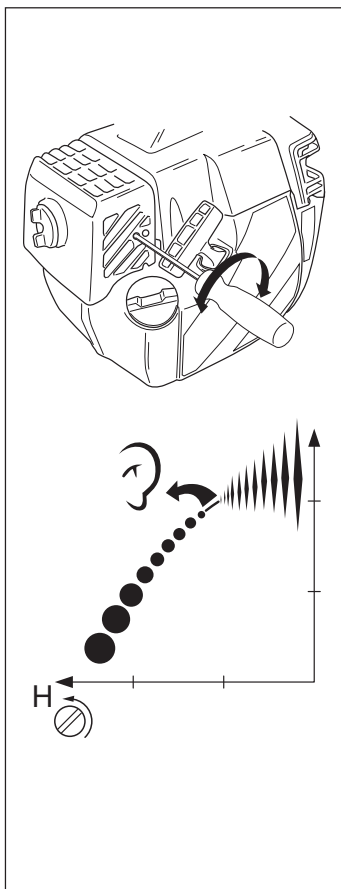

**NOTE!** For optimum setting of the carburettor, contact a qualified servicing dealer who has a revolution counter at his disposal.

## Correctly adjusted carburettor

A correctly adjusted carburettor means that the machine accelerates without hesitation and the machine 4-cycles a little at max speed. Furthermore, the cutting attachment must not rotate/move at idling. A too lean adjusted low speed needle L may cause starting difficulties and bad acceleration.

A too lean adjusted high speed needle H gives lower power = less capacity, bad acceleration and/or damage to the engine.

A too rich adjustment of the two speed needles L and H gives acceleration problems or too low working speed.



# MAINTENANCE

## Muffler

NOTE! Some mufflers are fitted with a catalytic converter. See "Technical data" to see whether your machine is fitted with a catalytic converter.

The muffler is designed to dampen the noise level and to direct the exhaust fumes away from the user. The exhaust fumes are hot and can contain sparks, which can result in fire if the exhaust fumes are directed towards a dry and inflammable material. Some mufflers are equipped with a special spark arrest screen. If your machine is fitted with this type of screen it should be cleaned regularly. This is done using a wire brush. On mufflers without a catalytic converter the screen should be cleaned weekly, or replaced if necessary. On mufflers fitted with a catalytic converter the screen should be checked and cleaned monthly. **If the screen is damaged it should be replaced.** If the screen is frequently blocked, this can be a sign that the function of the catalytic converter is impaired. Contact your dealer to inspect the muffler. A blocked screen will cause the engine to overheat resulting in damage to the cylinder and piston. Also see under "Maintenance".

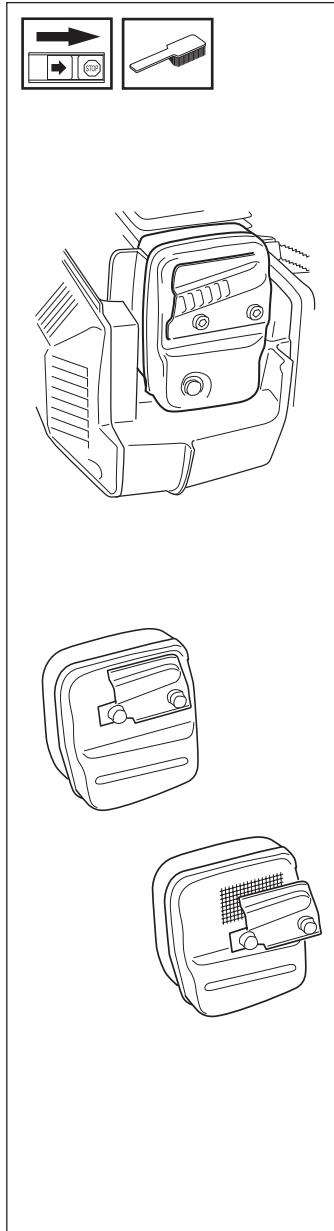

NOTE! Never use a machine with a defective muffler.



**WARNING!**  
Mufflers fitted with catalytic converters become extremely hot during use and after stopping. This also applies at idling speeds. Contact can result in burns to the skin. Be observant to the risk of fire!

## Cooling system

To maintain as low an operating temperature as possible the engine is equipped with a cooling system.

The cooling system consists of:

1. An air intake on the starter unit.
2. Cooling fins on the flywheel.
3. Cooling fins on the cylinder
4. Cylinder cover (leads cold air onto the cylinder).

Clean the cooling system using a brush at least once a week, in difficult conditions more often.

**A dirty or blocked cooling system leads to the engine overheating resulting in damage to the cylinder and piston.**

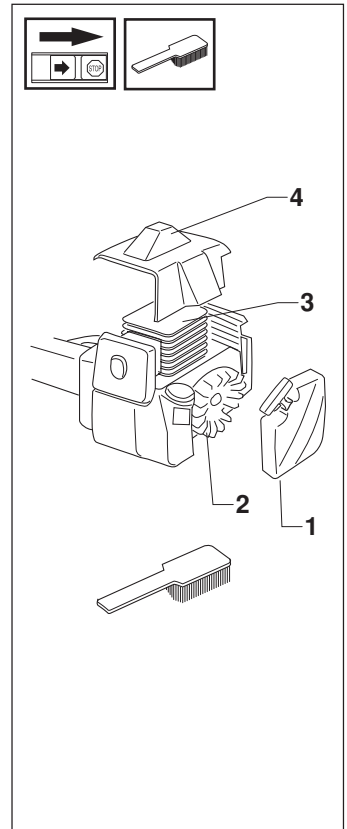

## Air filter

The air filter should be cleaned regularly removing dust and dirt to avoid:

- carburettor malfunction
- starting problems
- reduced engine power
- unnecessary wear to engine parts
- abnormal fuel consumption

Clean the filter after every 25 hours or more regularly if operating conditions are exceptionally dusty.

### Cleaning the air filter

Dismantle the air filter cover and remove the air filter. Wash in clean, warm soapy water. Ensure that the filter is dry before refitting. An air filter used for a long period of time can never be cleaned completely.

Therefore it is necessary to replace the filter from time to time with a new filter. A damaged air filter must always be replaced.

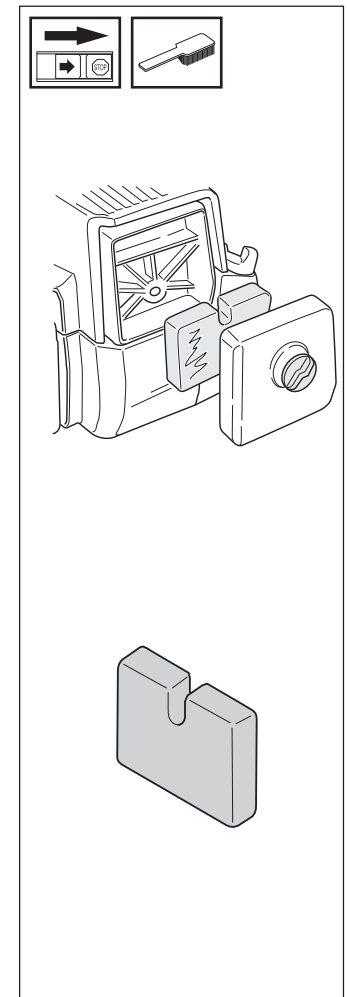

# MAINTENANCE

## Drive shaft

The flexible drive shaft is lubricated with special grease (art. no. 5038017-01). The shaft must be lubricated at least every 30 working hours. A tube of drive shaft grease is supplied with every machine.

NOTE! Do not use gearbox grease on the drive shaft.

- Separate the two rig shaft halves (see page 16).

- Remove the bolt that holds the drive shaft sleeve in the clutch cover.

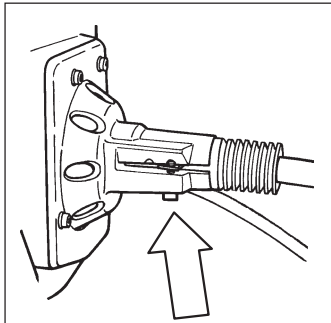

- Remove the clip that holds the throttle cable on the drive shaft.

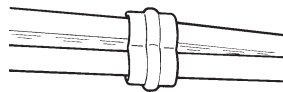

- Pull the drive shaft sleeve out of the clutch cover.

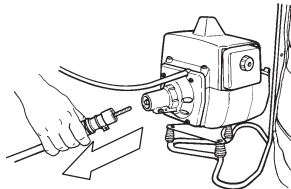

- Remove the drive shaft from the sleeve either by shaking it out or pulling it out using pliers.

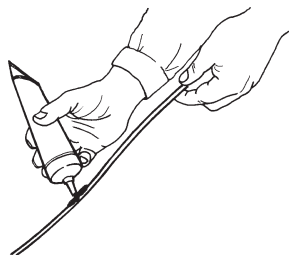

- Coat the surface of the shaft with grease from the tube. Spread it out using a brush or rag.

- Slide the drive shaft back into the sleeve. Make sure the shaft engages correctly by turning it and pushing at the same time.

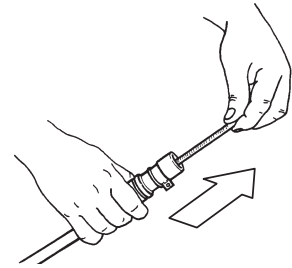

- When the shaft is correctly installed in the sleeve the end of the shaft should project about 30 mm beyond the edge of the sleeve.

- When the sleeve and drive shaft are installed in the clutch cover the guide pin (A) on the sleeve and the adjustable stop (B) must be positioned opposite each other.

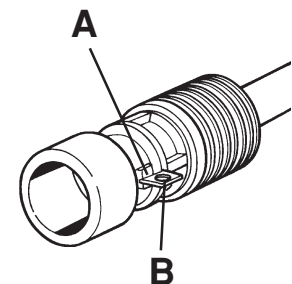

- Rotate the shaft and push it in at the same time.

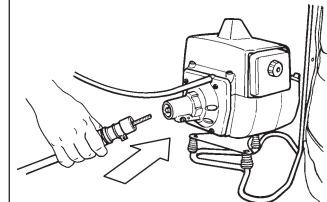

- Install the drive shaft sleeve in the clutch cover so that the stop locates in the slot on the underside of the clutch cover.

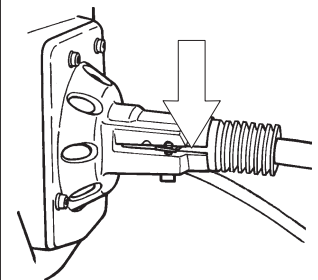

- Tighten the locking bolt. NOTE! The bolt must be inserted in the threaded half of the cover first, so that the cover is not drawn together.

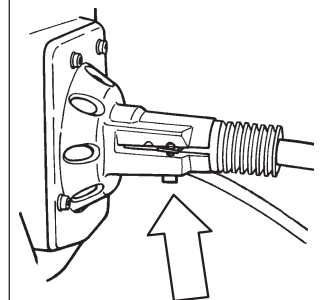

# MAINTENANCE

## Angle gear

The angle gear is filled with a sufficient quantity of grease at the factory. However, before using the machine you should check that the angle gear is filled to 3/4 with grease. Use JONSERED special grease. Normally, the grease does not need to be changed except when the angle gear is repaired.

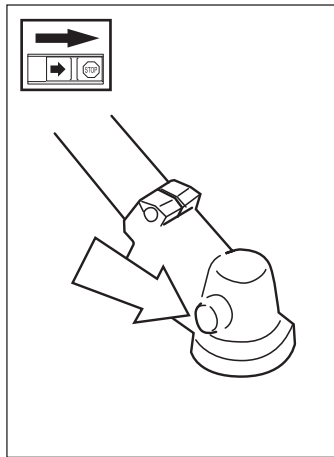

## Two-part shaft

The end of the drive shaft in the lower shaft should be lubricated with grease every 30 hours. There is a risk that the drive shaft ends (splined coupling) on two-part shafts jam if they are not lubricated regularly.

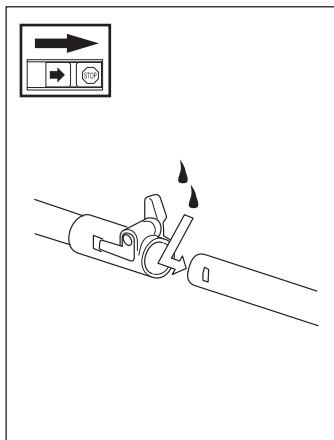

## Spark plug

The condition of the spark plug is affected by:

- An incorrect carburettor setting.
- An incorrect fuel mixture (too much or faulty oil).
- A dirty air filter.

These factors cause deposits on the spark plug electrode that may result in malfunction or starting difficulties.

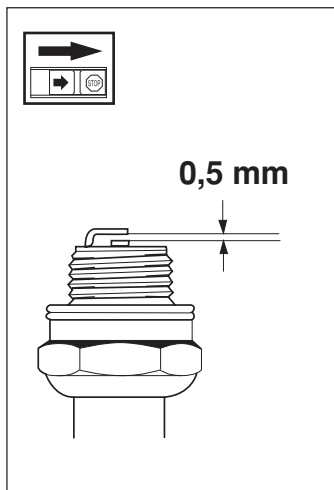

**If the machine is low on power, difficult to start or runs poorly while idling always check the spark plug first.**

If the spark plug is dirty, clean it and at the same time check that the electrode gap is 0.5 mm. The spark plug should be changed after about one month of operation or earlier if necessary.

**NOTE!** Always use the recommended type of spark plug. An incorrect spark plug can damage the cylinder/piston.

## Filing the grass blade



### WARNING!

Always stop the engine before starting work on any part of the cutting equipment. This continues to rotate even after the throttle has been released. Ensure that the cutting equipment has stopped completely and remove the cable from the spark plug before you start to work on it.

- See the cutting equipment's packaging for correct filing instructions.



- The blades are sharpened using a single cut flat file.
- Sharpen all edges equally to maintain the balance of the blade.

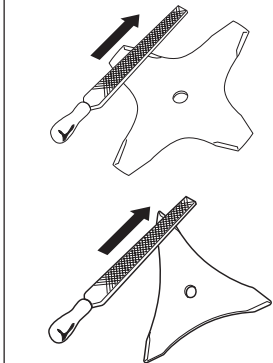

### WARNING!

Always discard a blade that is bent, twisted, cracked, shattered or damaged in any other way. Never attempt to straighten a twisted blade for use again. Only use original blades of the prescribed type.

# MAINTENANCE

## Maintenance schedule

Below follows some general maintenance instructions.  
If you need further information please contact your service workshop.

### Daily maintenance

1. Clean the outside of the machine.
2. Make sure the harness is not damaged.
3. Make sure the throttle trigger lock and the throttle function correctly from a safety point of view.
4. Check that the stop switch functions.
5. Check that the cutting head does not rotate while idling.
6. Clean the air filter. Replace if necessary.
7. Check the guards for damage and ensure that they are not cracked. Replace the guards if they have been exposed to impact or are cracked.
8. Check that the blade is well centred, is sharp, and is not cracked. An uncentred blade causes vibrations that can result in damage to the machine.
9. Check that the trimmer head is undamaged and not cracked. Replace the trimmer head if necessary.
10. Check that the locking nut is tight.
11. Check that the blade's transport guard is intact and that it can be secured correctly.
12. Check that all nuts and screws are tightened.

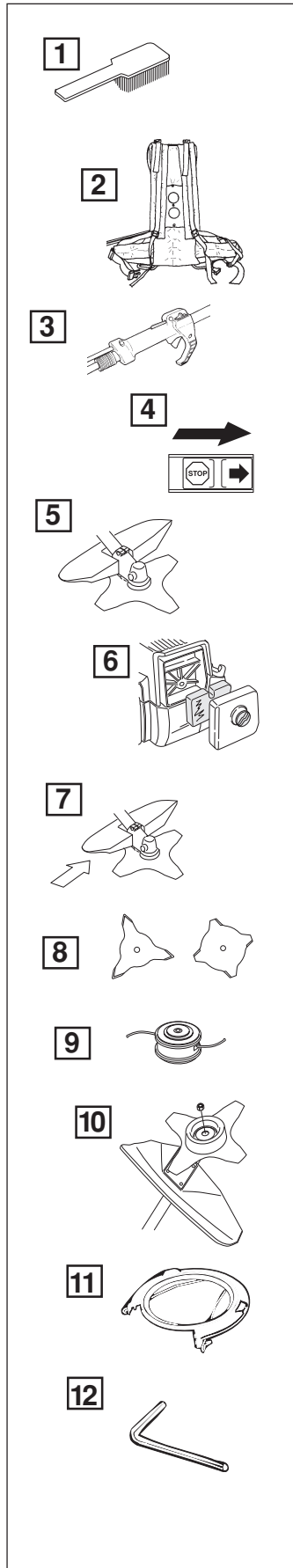

### Weekly maintenance

1. Check the starter, the starter cord and the return spring.
2. Make sure that the vibration damping elements are not damaged.
3. Clean the outside of the spark plug. Remove and check the electrode gap. Adjust the gap to 0,5 mm (0,02 inch) or change the spark plug.
4. Clean the cooling fins on the flywheel.
5. Clean or replace the muffler's spark arrest screen (not on mufflers with a catalytic converter).
6. Clean the carburettor area.
7. Clean the cooling fins on the cylinder and check that the air intake in the starter unit is not blocked.
8. Check that the angle gear is 3/4 filled with grease. Fill if necessary using special grease.
9. The flexible drive shaft must be lubricated every 30 working hours or more frequently.

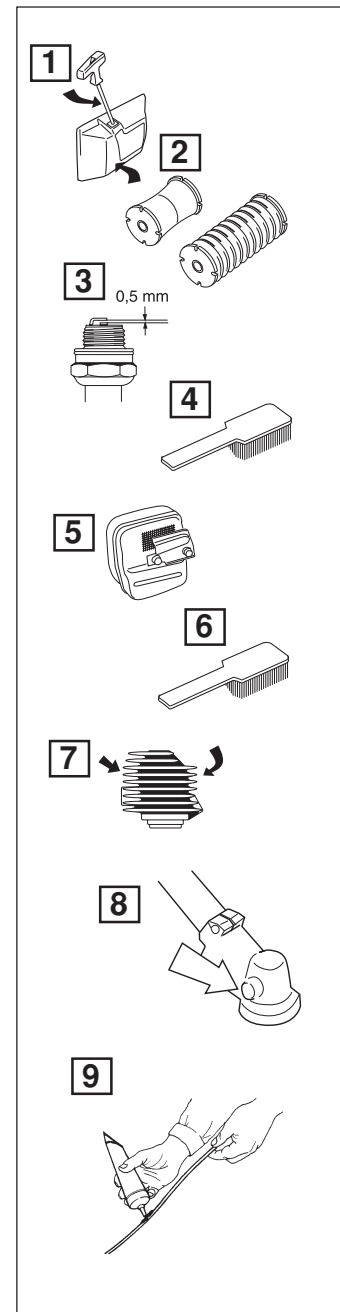

# MAINTENANCE

## Monthly maintenance

1. Clean the fuel tank using petrol.
2. Clean the carburettor and the area surrounding it.
3. Clean the fan and the area around it.
4. Check the fuel filter and the fuel pipe, replace if necessary.
5. Check all cables and connections.
6. Check the clutch, clutch springs and the clutch drum with regard to wear. Replace if necessary.
7. Change the spark plug.
8. Check and clean the muffler's spark arrest screen if necessary (only mufflers with a catalytic converter).

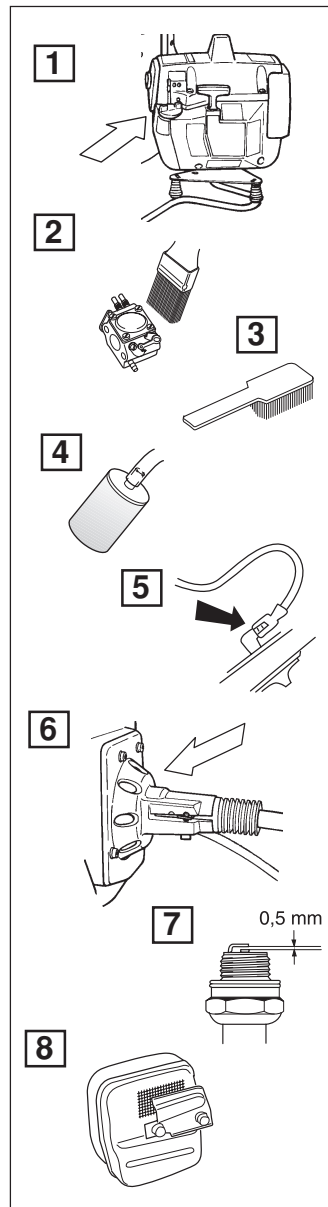

# TECHNICAL DATA

## Technical data

## BP 2040C

### Engine

Displacement, cm <sup>3</sup> /cu. inch	36,3/2,2
Cylinder bore, mm/inch	38/1,5
Stroke length, mm/inch	32/1,6
Idling speed, rpm	2 700
Recommended max. speed, rpm	10 000-10 700
Speed of output shaft, rpm	10 000
Max. engine output, acc. to ISO 8893	1,3 kW/ 9 000 rpm
Catalytic converter muffler	Yes
Speed-regulated ignition system	Yes

### Ignition system

Manufacturer/type of ignition system	Walbro CD
Spark plug	Champion RCJ 7Y
Electrode gap, mm/inch	0,5/0,02

### Fuel lubrication system

Manufacturer/type of carburettor	Walbro WT
Fuel tank capacity, litres/US pint	0,5/1,06

### Weight

Weight without fuel, cutting tool and guard, kg/Lbs	9,0/19,8
---	----------

### Noise emissions (see note 1)

Sound power level, measured dB(A)	109
Sound power level, guaranteed L <sub>WA</sub> dB(A)	110

### Sound levels (see note 2)

Equivalent sound pressure level at the user's ear, measured according to EN ISO 11806 and ISO 7917, dB(A), min/max:	89/99
---	-------

### Vibration levels

Vibration levels on the handles, measured according to EN ISO 11806 and ISO 7916, m/s <sup>2</sup>	
When idling, left/right handles, min:	1,2/1,3
When idling, left/right handles, max:	1,2/1,3
At max. speed, left/right handles, min:	3,0/5,1
At max. speed, left/right handles, max:	3,8/5,2

Note 1: Noise emissions in the environment measured as sound power (L<sub>WA</sub>) in conformity with EC directive 2000/14/EC.

Note 2: Equivalent sound pressure level is calculated as the time-weighted energy total for sound pressure levels under various working conditions with the following time distribution: 1/2 idling and 1/2 max speed.

**NOTE!** Sound pressure at the user's ear and vibrations on the handles are measured with all the machine's approved cutting equipment fitted. The table indicates the highest and lowest values.

### Approved accessories BP2040C

	Type	Cutting attachment guard Art No.
Centre hole in blades Ø 20 mm		
Threaded blade shaft M10		
Grass blade	Grass 255-4 (Ø 255 4-teeth)	503 74 40-03
	Grass 255-8 (Ø 255 8-teeth)	503 74 40-03
	Grass 275-4 (Ø 275 4-teeth)	503 74 40-03
	Multi 255-3 (Ø 255 3-teeth)	503 74 40-03
	Multi 275-4 (Ø 275 4-teeth)	503 74 40-03
Plastic knives	Polytrim Ø 300	503 74 50-03
Trimmer head	Tap-N-Go Pro	503 74 50-03
	Auto 32	503 74 50-03
	Trimmy HII	503 74 50-03
Edger	Edger attachment Ø 200	-
Hedge trimmer	Hedge trimmer attachment	-
Support cup	Fixed	-



## EC declaration of conformity (Applies to Europe only)

**Jonsered**, SE-561 82 Huskvarna, Sweden, tel +46-36-146500, declare under sole responsibility that the clearing saw Jonsered **BP2040C** with serial number from year 2002 and onwards (the year is clearly stated in plain text on the type plate with subsequent serial number), is in conformity with the following standards or other normative documents following the provisions in the COUNCIL'S DIRECTIVES:

- of June 22, 1998 "relating to machinery" **98/37/EC**, annex IIA.
- of May 3, 1989 "relating to electromagnetic compatibility" **89/336/EEC**, and applicable supplements.
- of May 8, 2000 "relating to the noise emissions in the environment" **2000/14/EC**.

For information relating to noise emissions, see the chapter Technical data.

The following standards have been applied: **EN 292-2, CISPR 12:1997, EN ISO 11806**.

**SMP Svensk Maskinprovning AB**, Fyrisborgsgatan 3, SE-754 50 Uppsala, Sweden, has carried out voluntary type approval for Huskvarna AB. The certificates are numbered: **SEC/97/540, 01/165/002**.

Huskvarna January 3, 2002



Bo Andréasson, Development manager

# Auto 32



1

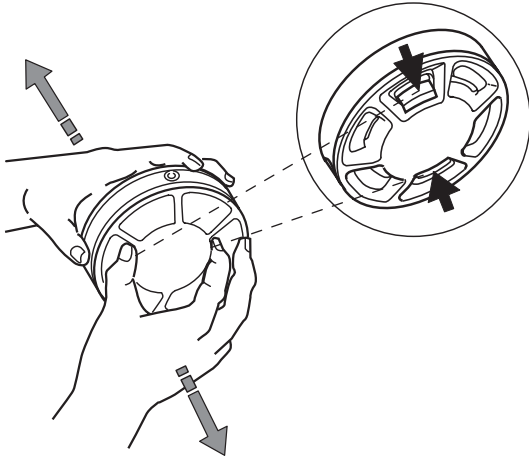

2

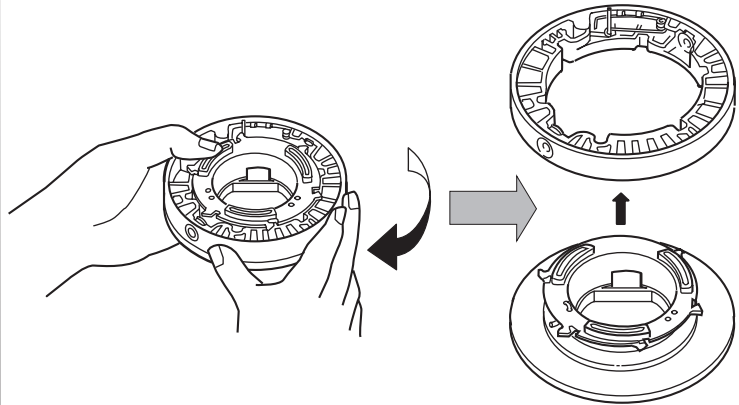

3

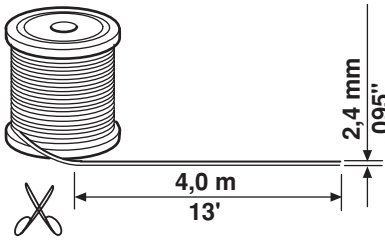

4

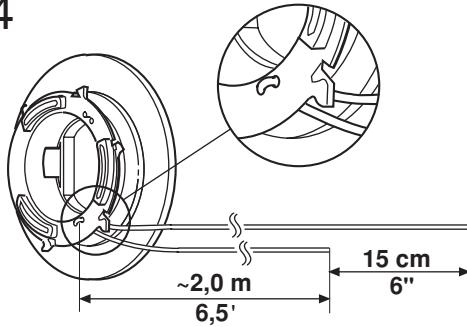

5

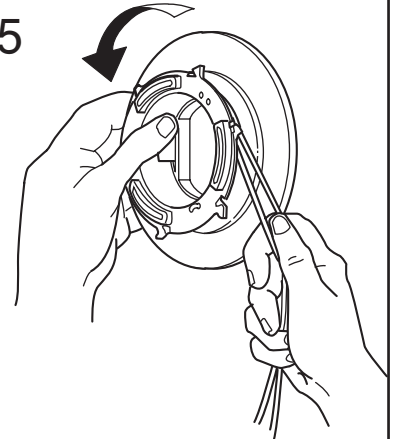

6

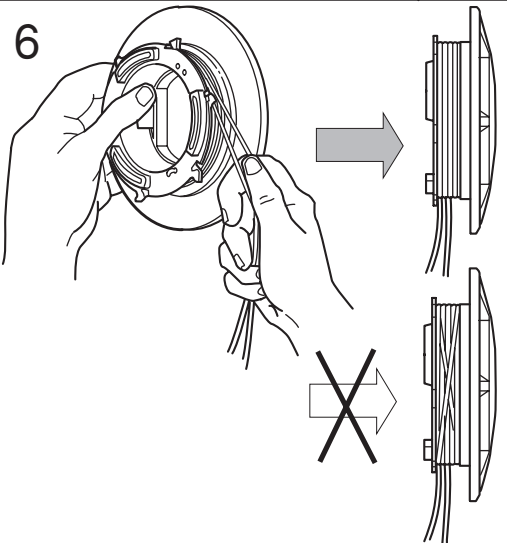

7

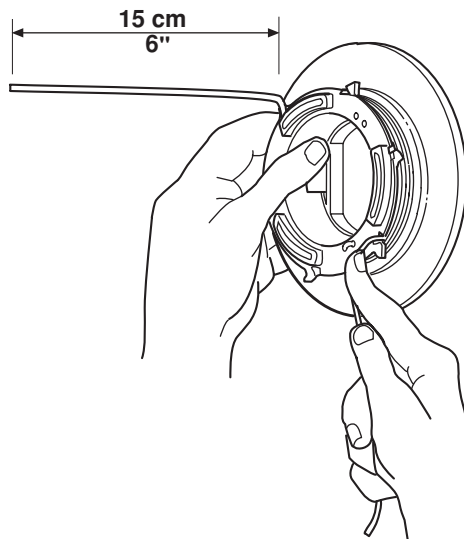

8

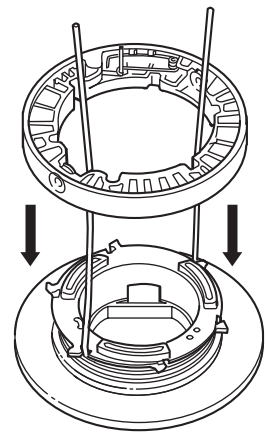

9

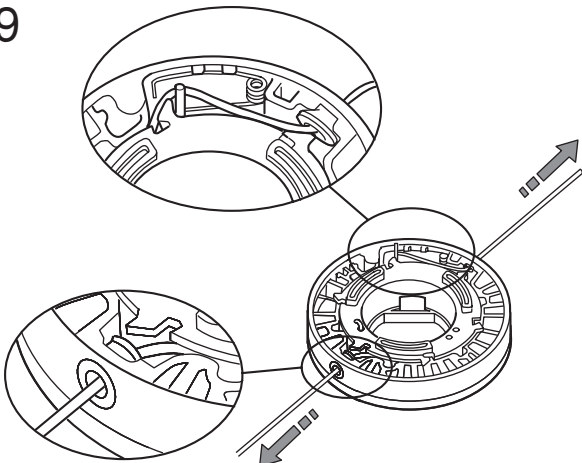

10

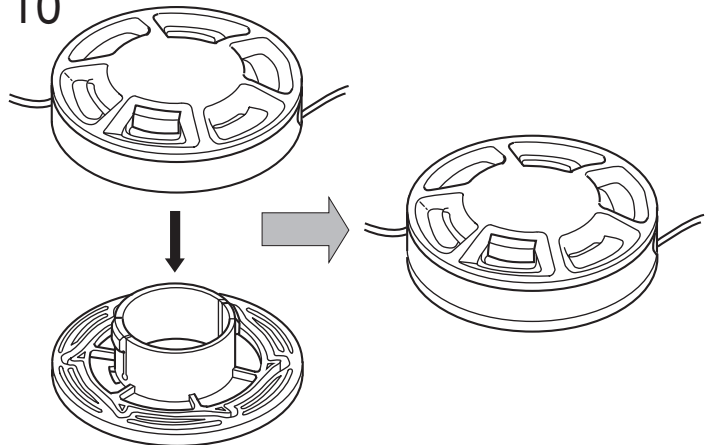

# Poly Trim

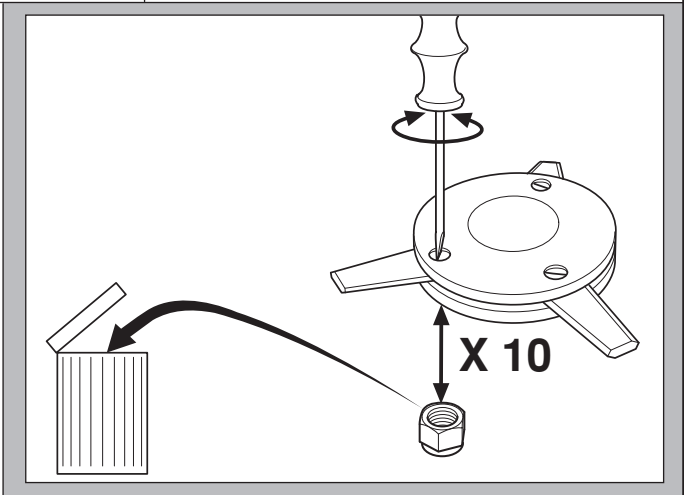
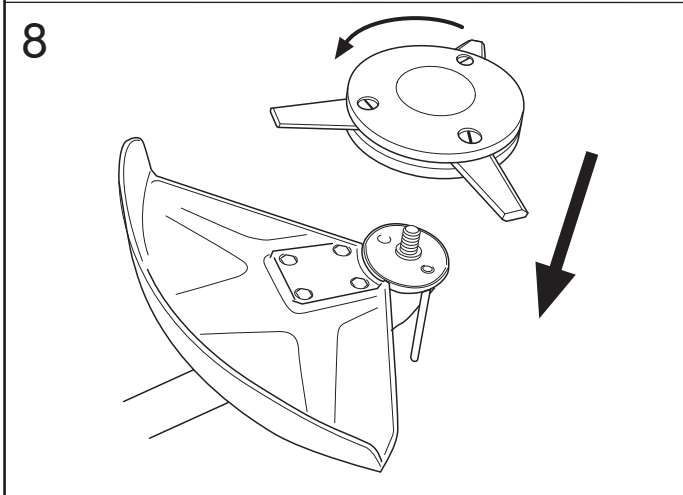
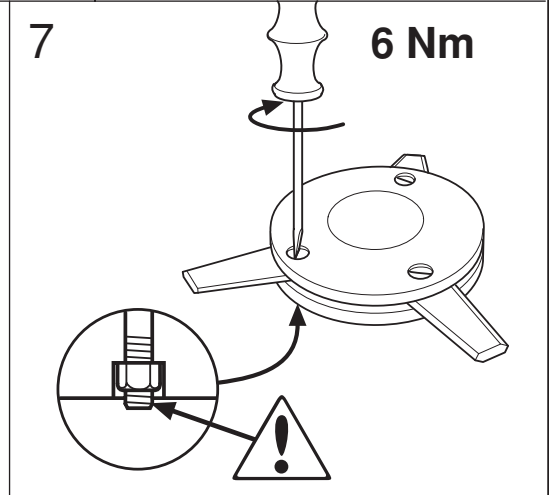
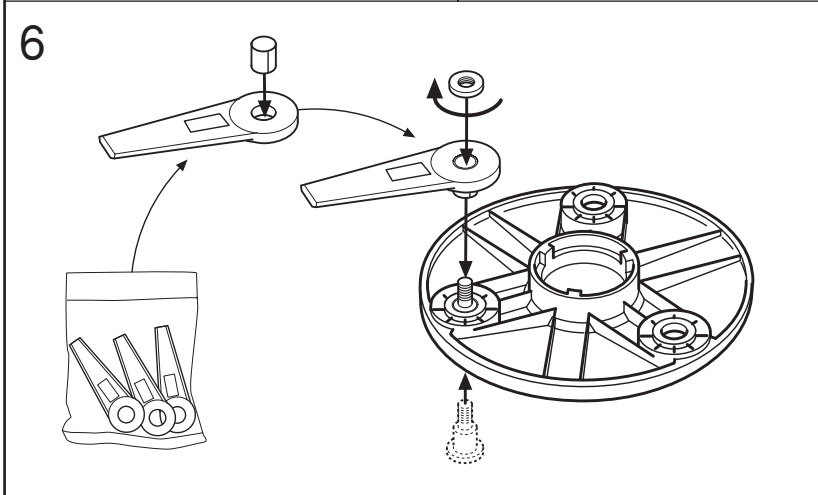
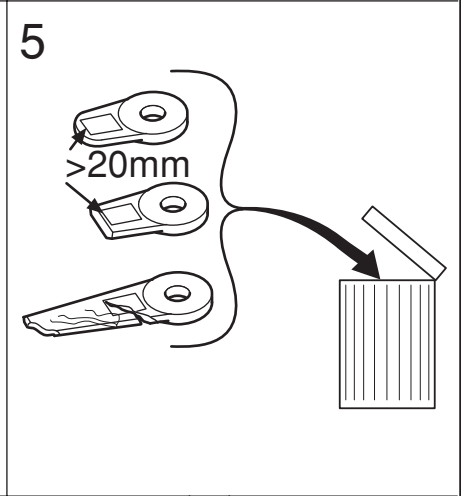
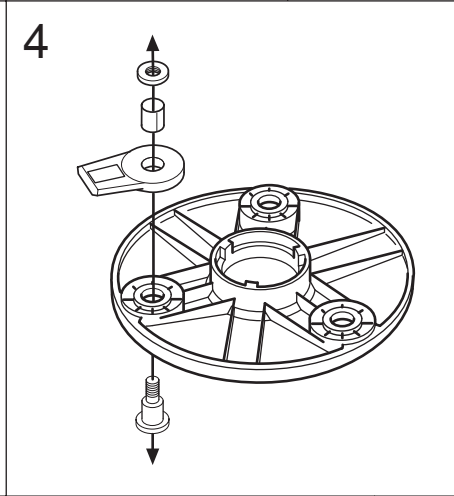
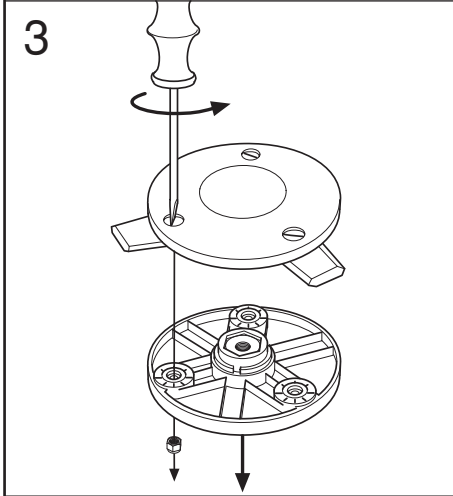
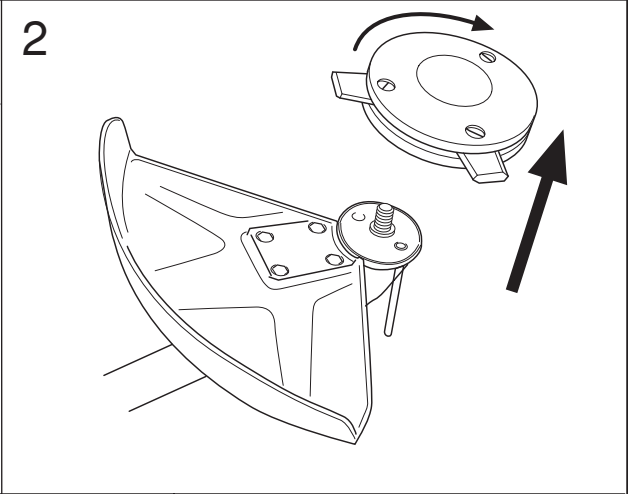
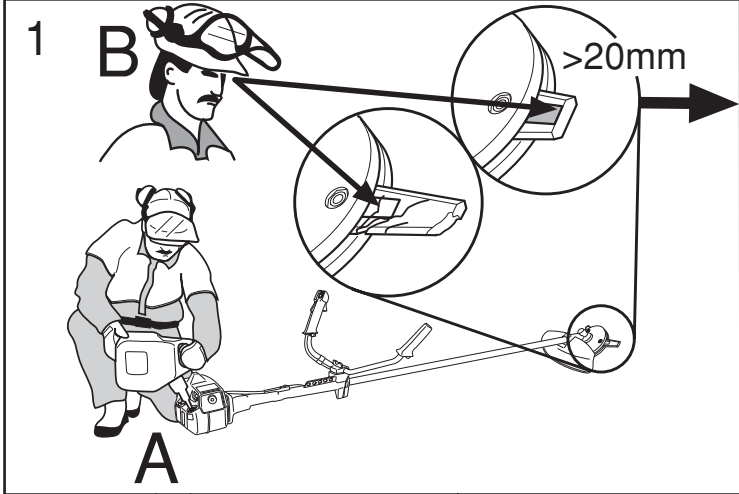

# Tap-N-Go Pro

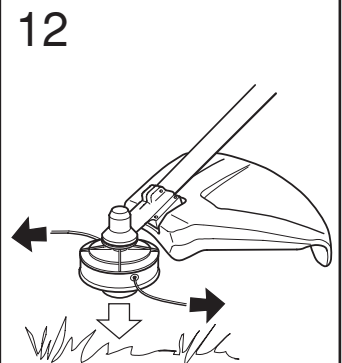
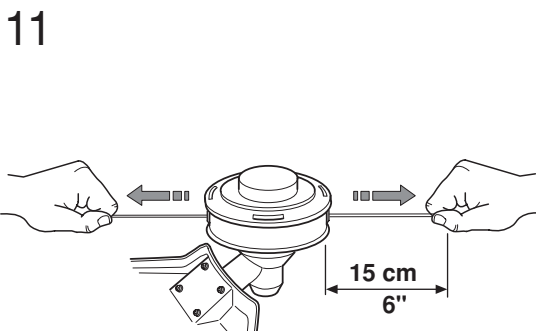
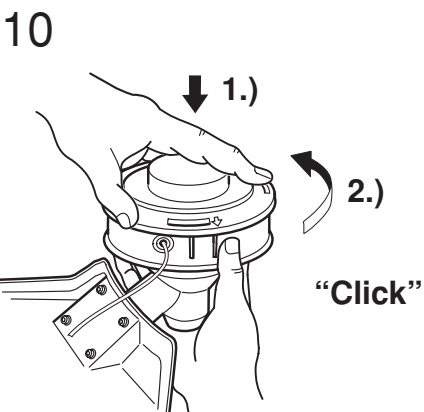
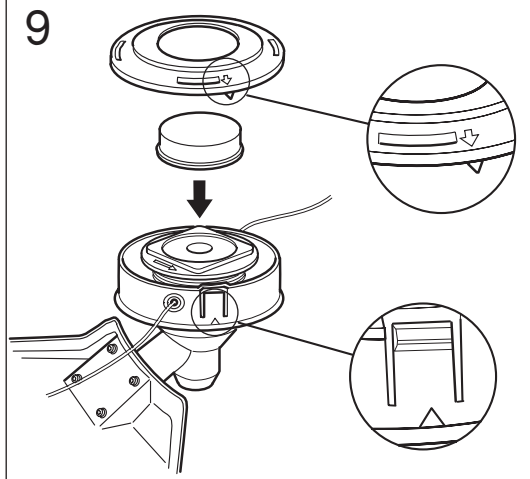
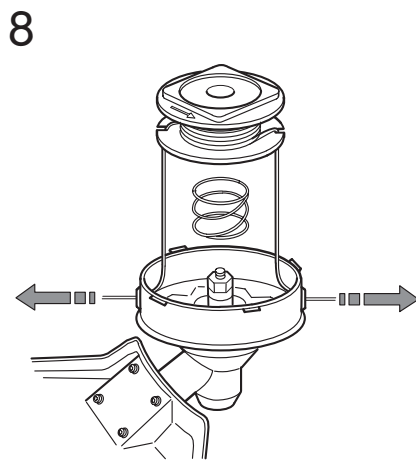
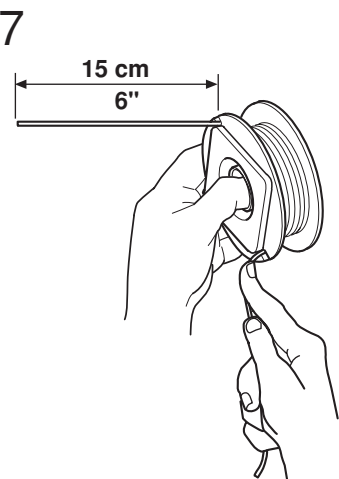
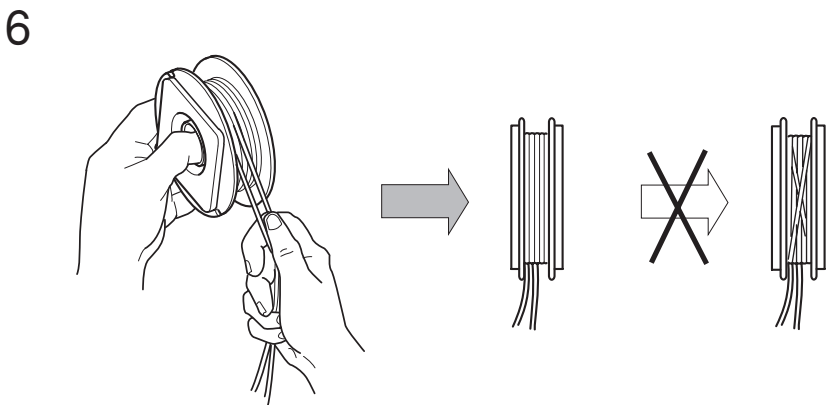
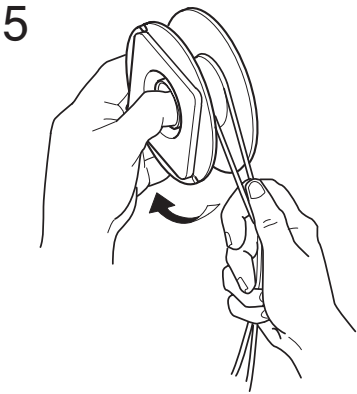
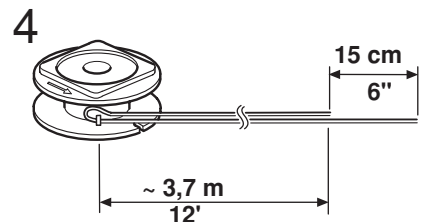
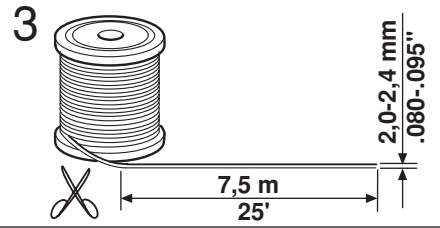
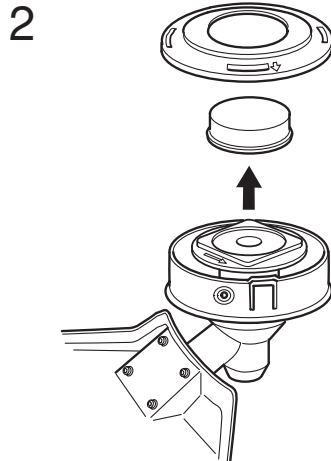
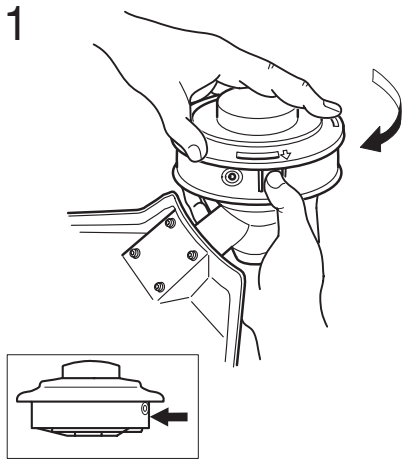

# Trimmy H II



1

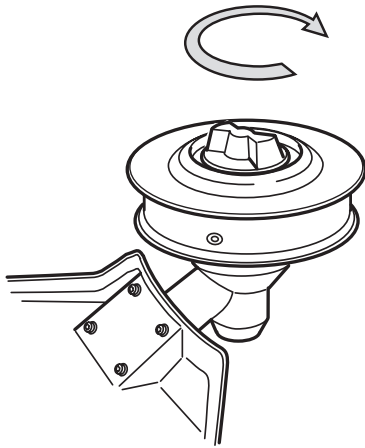

2

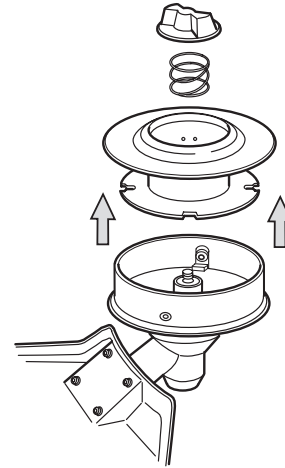

3

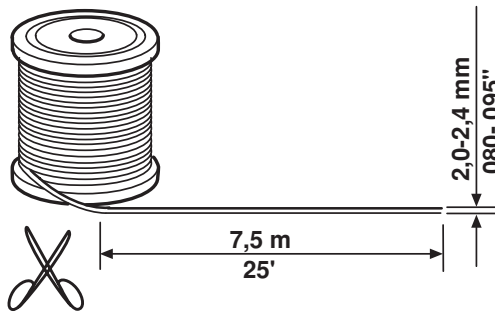

4

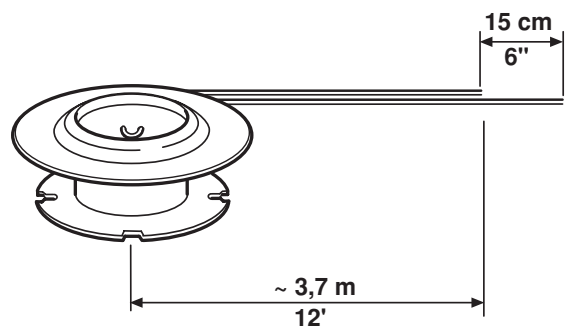

5

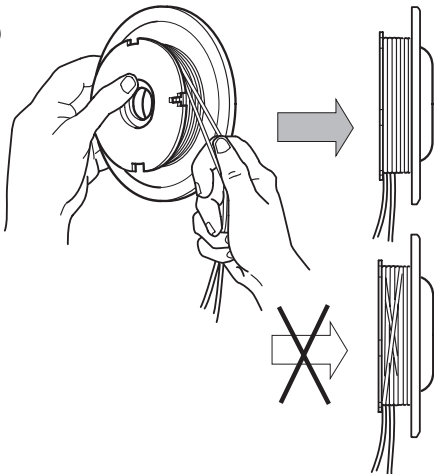

6

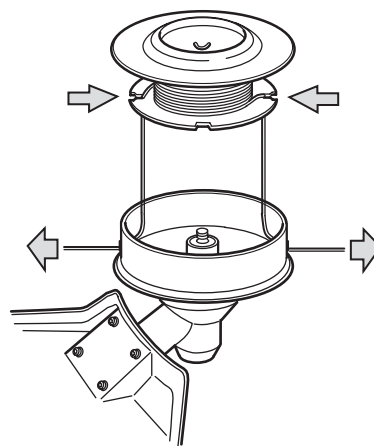

7

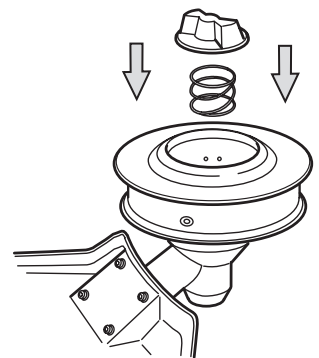

8

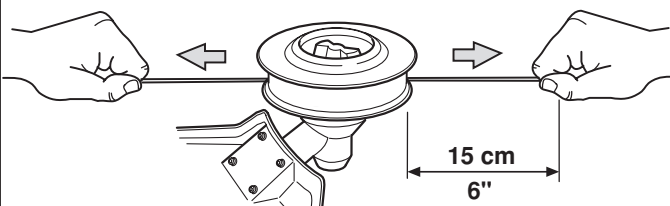

9

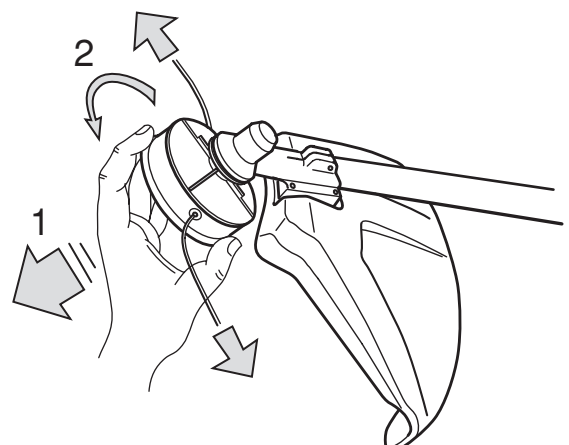

# Trimmy SII



1

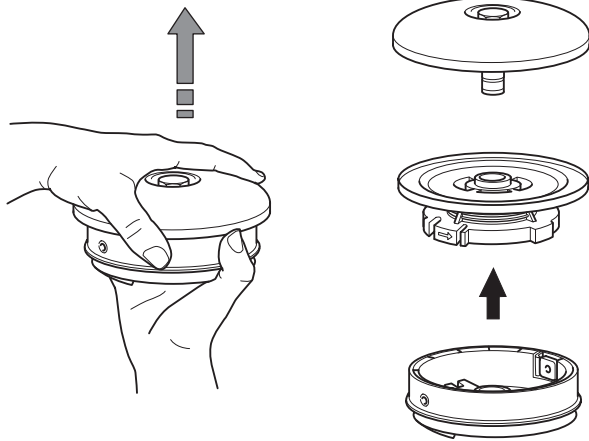

2

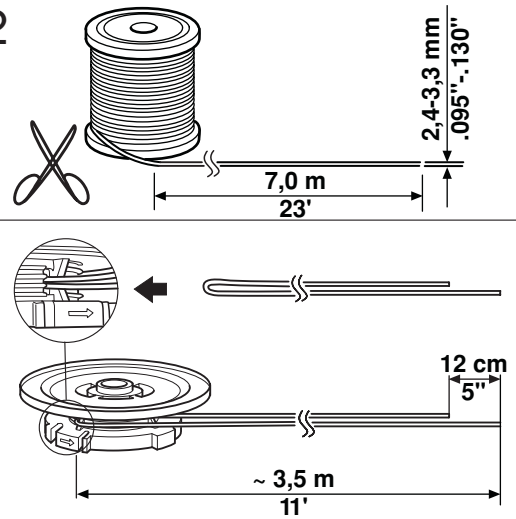

3

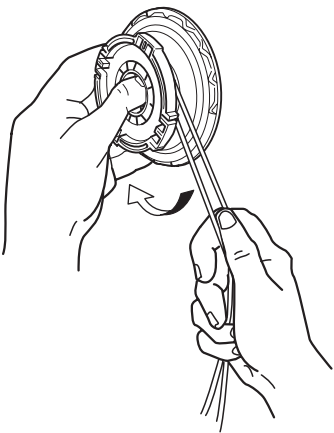

4

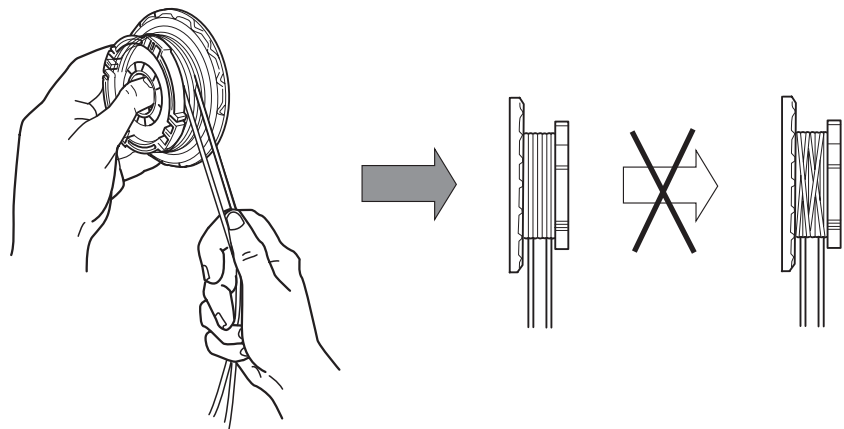

5

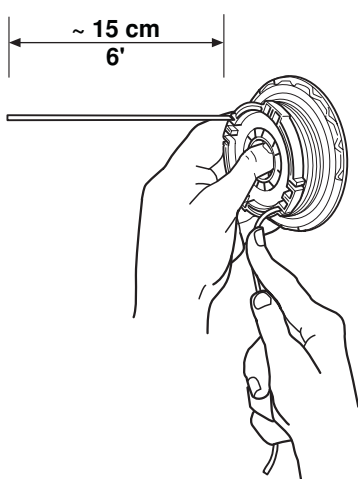

6

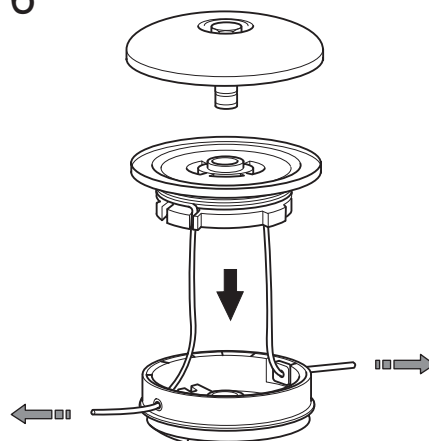

7

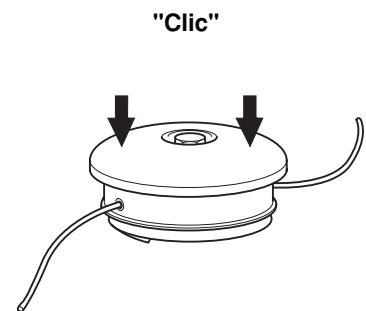

8

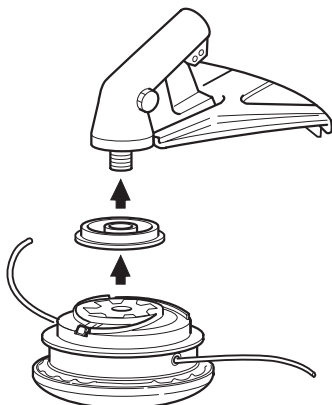

9

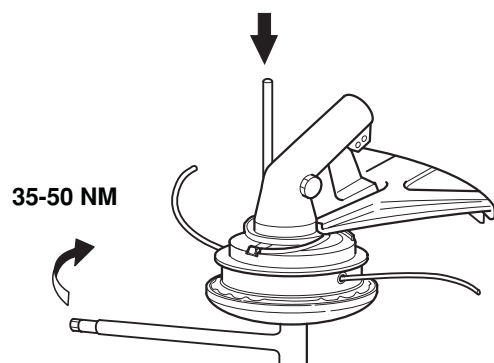



# Trimmy SII

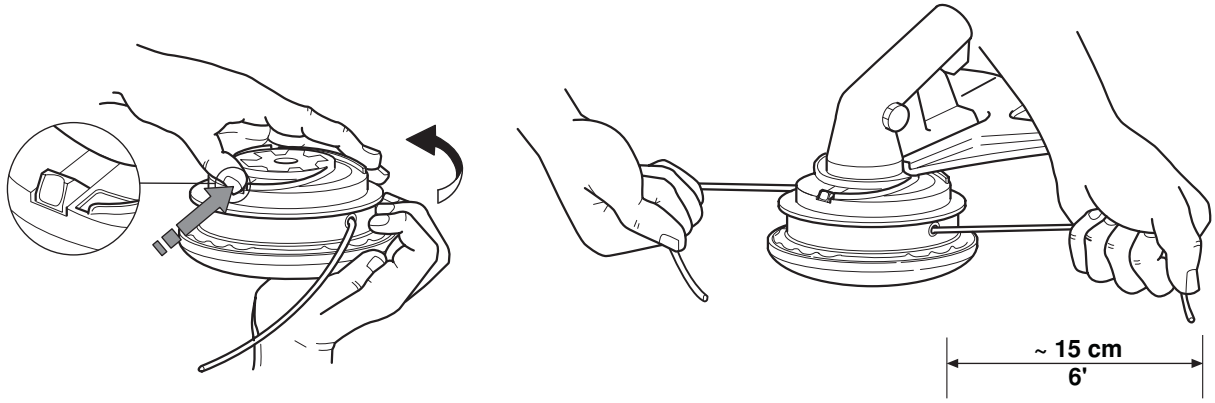

1

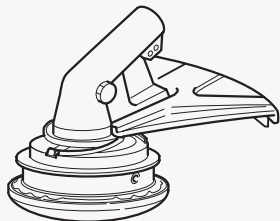

2

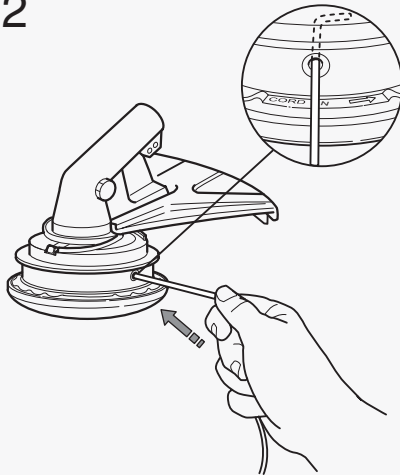

3

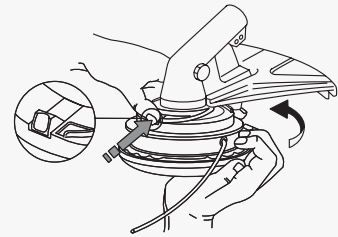

4

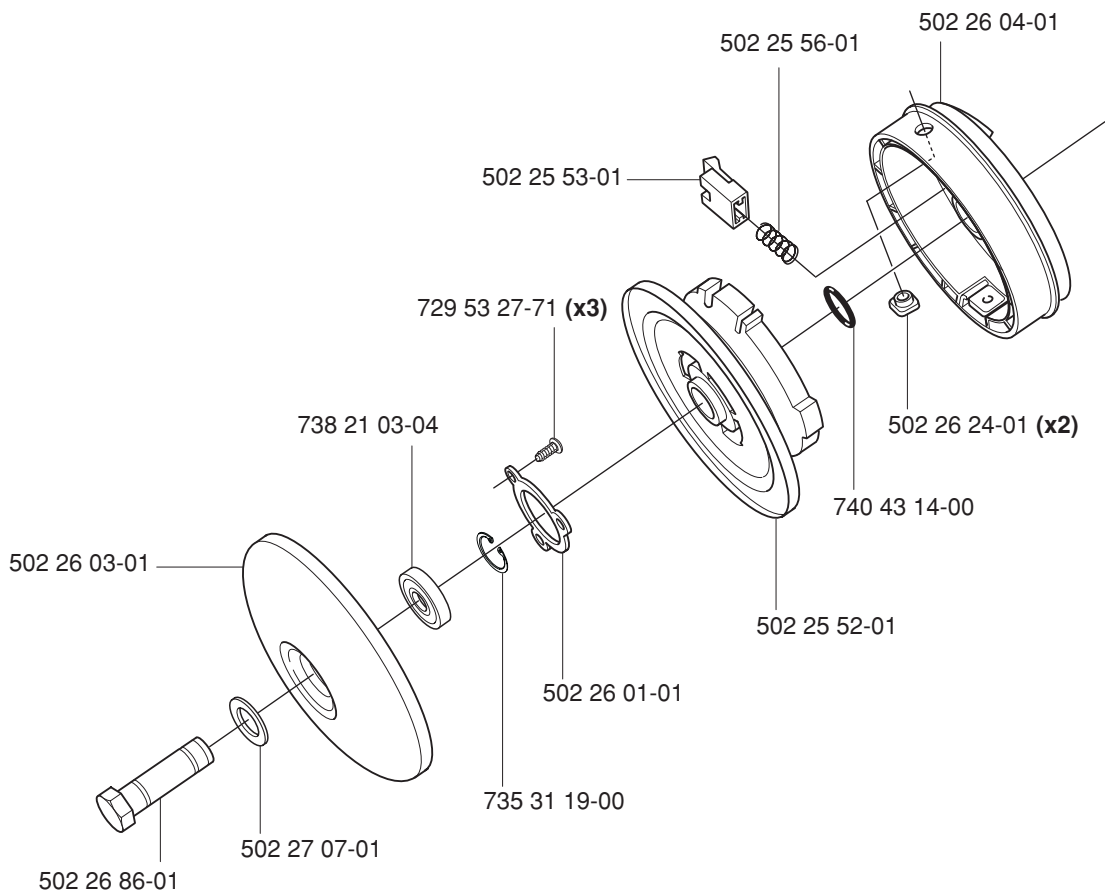
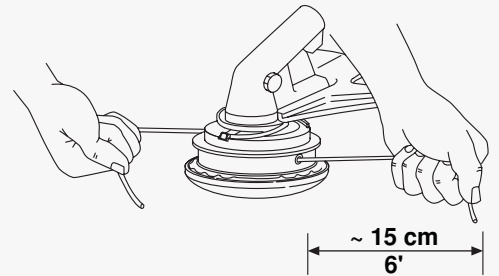





**.Jonsered**

108 88 40-26



2002W08